

BREMSSCHEIBEN

DISQUES DE FREINS

BRAKE DISCS



BREMSSCHEIBEN BRAKE DISCS *DISQUES DE FREINS*

Austausch-Bremsscheiben mit ABE aus hochwertigem Stahl

- » extrem formbeständiger Stahl nach 35 HRC Standard, gehärtet und thermisch nachbehandelt
- » spezieller Oberflächenschliff wirkt Vibrationen entgegen und verbessert die Anpassung der Beläge
- » bei den schwimmenden Bremsscheiben ist der gefräste Innenring aus Aluminium und edel titanfarben eloxiert
- » Korrosionsschutz durch hohen Edelstahlanteil
- » verwendbar mit allen TRW-Belagmischungen
- » **Bremsscheiben werden einzeln geliefert**

Replacement brake discs made from high-grade steel, TÜV approved

- » *high-strength steel alloy in accordance with standard 35 HRC, hardened and tempered*
- » *special ground surface finish assists in reducing vibration and improves pad performance*
- » *the ground inner ring of floating brake discs is made of aluminium and exclusively anodized in a titanium colour finish*
- » *corrosion protection due to high ratio of stainless steel*
- » *can be used with all types of TRW pads*
- » **brake discs are supplied individually**

Disque de freins de rechange fabriqué dans un inox de très haute qualité

- » *acier indéformable, selon le HRC 35 standard, durci et soumis à un post-traitement thermique*
- » *parfait état de surface pour éviter les vibrations et améliorer la performance des plaquettes*
- » *la frète intérieure de ce disque flottant est réalisé en aluminium avec une anodisation particulière en couleur gris titane*
- » *protection contre la corrosion garantie par une teneur élevée en acier inoxydable*
- » *compatibles avec les autres qualités de plaquettes TRW*
- » **les disques de frein sont fournis à la pièce**

RAC-BREMSSSCHEIBEN

RAC BRAKE DISCS DISQUES DE FREIN RAC

Superleicht und extrem hitzebeständig!

Superlight and extremely heat-resistant!

Extrêmement légers et très résistants aux températures élevées!



Cooler Design, Hightech-Produktion, mit ABE, zum attraktiven Preis:

- » Hochleistungslaserschneider ermöglichen filigrane Formgebung
- » selbst bei hoher Beanspruchung geringer Verschleiß
- » konstante Aufrauung verhindert die Verglasung der Beläge
- » gleichmäßiger Temperaturauf- und -abbau
- » die RAC-Kontur ermöglicht einen stabilen Druckpunkt
- » einsetzbar in allen Rennsportkategorien

Cool design, high technology production, TÜV approved, at an attractive price:

- » outstanding silhouette produced by high-performance laser cutting
- » low wear even under high stress
- » constant roughening prevents glazing of the pads
- » uniform increase and decrease in temperature
- » the RAC contour ensures a stable pressure point
- » can be used in all categories of motor sport

Un super design, une technologie de pointe, TÜV homologué, à un prix très attractif:

- » un dispositif de coupe en laser de haute performance permet d'obtenir des disques façonnés tout en finesse
- » faible usure, même en cas d'importantes sollicitations
- » la rugosité constante empêche que les plaquettes deviennent lisses
- » baisse et une montée régulières de la température
- » le contour RAC garantit un point de pression stable
- » utilisables dans toutes les catégories de courses sportives



BREMSSCHEIBEN FÜR BMW

BRAKE DISCS FOR BMW DISQUES DE FREINS POUR BMW

Die innovative Konstruktion des Floating-Systems (FS) unterstützt die Lösung von Bremsproblemen. Die voll schwimmend gelagerten Scheiben optimieren Hitzeableitung und beugen einem durch Verzug bedingten Bremsrubbeln vor. Das individuelle Design unterstützt sportliches Bremsverhalten und trägt zur Optimierung der Bremsanlage bei. Die Scheiben sind auch bei ABS-Modellen einsetzbar.

- » innovative Konstruktion
- » Bremsoptimierung
- » hohe Hitzeableitung
- » ansprechendes Design
- » für extreme Beanspruchung
- » auch für ABS Modelle

The innovative design of the Floating System (FS) assists in solving brake problems. The fully floating discs optimise heat dissipation and prevent brake judder caused by warping. The individual design assists sport braking and helps optimise the brake system. The discs can also be used on ABS models.

- » innovative design
- » brake optimisation
- » high heat dissipation
- » attractive design
- » for extreme demands
- » also for ABS models

La construction innovante du système flottant (FS, Floating-System) contribue à la résolution des problèmes de freinage. Les disques entièrement flottants sur palier optimisent l'évacuation de la chaleur et préviennent le frottement des freins dû au voile. Cette conception individuelle confère aux freins un comportement sportif et contribue à l'optimisation du système de freinage. Les disques sont également compatibles avec les modèles équipés de l'ABS.

- » construction innovante
- » optimisation des freins
- » grande capacité d'évacuation de la chaleur
- » design attrayant
- » pour les sollicitations extrêmes
- » également disponible pour les modèles équipés de l'ABS



Floating System (FS) Bremsscheibe im RAC-Design

Floating System disc – RAC design

Disque de frein flottant (FS) – RAC design

**Mit ABE –
kein TÜV nötig!**
TÜV approved!
TÜV homologué!



Starre Standard-Bremsscheibe

Fixed disc – standard design

Disque de frein fixe standard



Starre Bremsscheibe im RAC-Design

Fixed disc – RAC design

Disque de frein fixe – RAC design

MONTAGEZUBEHÖR FÜR BMW-SCHEIBEN

ACCESSOIRES DE MONTAGE POUR DISQUES BMW
FITTING KITS FOR BMW DISCS

	TRW-Bremsscheibe TRW Brake disc Disque de frein TRW					
	MST238 (RAC) MST356 (RAC)	MST238 (RAC) MST356 (RAC)	MST239 (RAC) MST357 (RAC)	MST239 (RAC) MST357 (RAC)	MST239FS MST357FS	MST239FS MST357FS
Stärke <i>Thickness</i> <i>Épaisseur</i>	4,5 mm	4,5 mm	5 mm	5 mm	5 mm	5 mm
OE-Ausführung <i>OE version</i> <i>Modèle OE</i>	verschraubt <i>bolted</i> <i>vissé</i>	vernietet <i>riveted</i> <i>riveté</i>	verschraubt <i>bolted</i> <i>vissé</i>	vernietet <i>riveted</i> <i>riveté</i>	verschraubt <i>bolted</i> <i>vissé</i>	vernietet <i>riveted</i> <i>riveté</i>
Baujahr <i>Year of manufacture</i> <i>Année de construction</i>	- 11/2007	12/2007 -	- 11/2007	12/2007 -	- 11/2007	12/2007 -
Montagezubehör <i>Fitting kit</i> <i>Accessoire de montage</i>	OE optional MST13FK	MST14FK	OE optional MST15FK	MST16FK	nicht nötig <i>not necessary</i> <i>inutile</i>	MST12FK
Schrauben <i>Bolts</i> <i>Vis</i>	OE	OE	OE	OE	OE	OE
Einbauhinweis <i>Installation information</i> <i>Consigne de montage</i>						

OE = Originalteile | OE = Original Equipment | OE = Pièces d'origine

Inhalte | Contents | Contenus



BREMSSCHEIBEN-VARIANTEN

VARIANTES DE DISQUES DE FREIN

BRAKE DISC VERSIONS

ALLROUND MIT ABE

- » runde Außenkontur mit gelochtem Bremsband
- » in starrer und schwimmender Variante
- » für Hinter- und Vorderachse

» TÜV approved

- » round external contour with perforated brake band
- » fixed and floating version available
- » for front and rear axle

» TÜV homologué

- » contours extérieurs arrondis avec ruban de frein perforé
- » variantes fixes et flottantes
- » pour essieux avant et arrière



EC MIT ABE

siehe Seite 14

TÜV approved, see page 14
TÜV homologué, cf. page 14



FS MIT ABE

siehe Seite 2.04

TÜV approved, see page 2.04
TÜV homologué, cf. page 2.04



SL OHNE ABE

- » nur für Rennsportzwecke
- » Hinterachsen-Scheibe im RAC Design
- » besonders leichte Ausführung

» without TÜV approval,

- for racing use only
- » rear axle disc in RAC design
- » particularly lightweight version

» sans TÜV, uniquement pour les sports de course

- » Disque pour essieu arrière, design RAC
- » Modèle particulière léger

RAC MIT ABE

- » eingekerbte Außenkontur mit geschlitztem Bremsband
- » in starrer und schwimmender Variante
- » für Hinter- und Vorderachse

» TÜV approved

- » notched external contour with notched brake band
- » fixed and floating version available
- » for front and rear axle

» TÜV homologué

- » contours extérieurs rainurés avec ruban de frein fendu
- » variantes fixes et flottantes
- » pour essieux avant et arrière





Adly

	50	/90/100 Road Tracker		04-06	MST 250					155				
	50	Super Sonic	SS-100	04-	MST 243		RAC			190				
	90	Road Tracer		02-	MST 250					155				
	100	Road Tracer		02-	MST 250					155				
SS	100	Super Sonic		04-	MST 243		RAC			190				
SS	125	Super Sonic		04-	MST 243		RAC			190				
TB	125	Thunderbike	TB-125		MST 243		RAC			190				

Aprilia

	50	Amico	GC	92-	MST 250					155				
	50	Amico GL	HV	94-	MST 250					155				
	50	Area 51	MY	98-01					MST 236		RAC		190	
	50	Gulliver AC	LH 02	95-00	MST 236		RAC			190				
	50	Gulliver LC	LH	97-00	MST 236		RAC			190				
	50	Habana	PK	98-02	MST 236		RAC			190				
	50	Mojito/ Mojito custom	PK	03-	MST 236		RAC			190				
	50	Rally AC	MD 01	95-00	MST 236		RAC			190				
	50	Rally LC	MD 01	96-98	MST 236		RAC			190				
	50	Rally LC	MD	97-01	MST 236		RAC		190	MST 236		RAC		190
	50	Sonic LC, AC	PB	98	MST 250					155				
	50	Scarabeo de lux	PF	98-	MST 253					220	MST 236		RAC	190
	50	Scarabeo Di-Tech	SC	02-						MST 236		RAC		190
	50	Sport City, Sport City One		08-11	MST 254					220				
SR	50	Di-Tech	RL	00-	MST 236		RAC		190	MST 236		RAC		190
SR	50	Ditech LC	LC	02-03	MST 236		RAC		190	MST 236		RAC		190
SR	50	LC	MR	93-00	MST 236		RAC		190					
SR	50	AC	LB	93-96	MST 236		RAC		190					
SR	50	LC Waterc.	LC	93-97	MST 236		RAC		190	MST 236		RAC		190
SR	50	Stealth LC	LC	96-00	MST 236		RAC		190	MST 236		RAC		190
SR	50	Street LC	LC	03-	MST 236		RAC		190	MST 236		RAC		190
SR	50	R Factory LC		04-	MST 236		RAC		190	MST 236		RAC		190
SR	50	R		10-	MST 236		RAC		190					
SR	50	/125 Motard		12-	MST 254					220				
SR	50	www	LY	97-01	MST 236		RAC		190					
	100			00-	MST 253					220				
	125	Atlantic	SP	03-04							MST 236		RAC	190
	125	Habana	PM	00-02	MST 236		RAC		220					
	125	Mojito/ Mojito custom	RY	03-	MST 236		RAC		220					
	125	Leonardo	MB 00	96-04	MST 253				220	MST 236		RAC		190
	125	Leonardo	TB	05-	MST 253				220					
	125	Pegaso	ET	89-99	MST 337				298					
	125	Scarabeo	PF	99-03	MST 253				220	MST 236		RAC		190
	125	Scarabeo	TD	04-07	MST 253				220	MST 253				220
	125	Scarabeo	VR	07-09	MST 409				260	MST 253				220
	125	Sport City, City Cube	VB	04-	MST 409				260	MST 253				220
	125	Sport City One	SG	08-	MST 254				220					
AF1	125	Futura	FM	90-92	MSW 211		RAC		320					
RS	125	Replica Extrema	GS	92-	MSW 211		RAC		320					
RS	125	Alitalia		11-	MSW 211		RAC		320					
SR	125		PX	99-02	MST 236		RAC		190					
SR	125	Max ie		11-	MST 393				260	MST 395				240
	150	Leonardo	MB	97-04	MST 253				220	MST 236		RAC		190
SR	150		PX	00-02	MST 236		RAC		190					
	200	Atlantic	SP	03-04						MST 236				190
	150	Scarabeo	SD	99-	MST 253				220	MST 253				220
	200	Sport City	VB	04-08	MST 409				260	MST 253				220
	250	Leonardo	PD	99-04	MST 253				220					
	250	Scarabeo	VR	06-10	MST 253				220	MST 253				220
	250	Sport City, City Cube	VB	06-09	MST 409				260	MST 253				220
	300	Leonardo	SV	05-06	MST 253				220					
	300	Scarabeo S	VR	09-10	MST 409				260					
	300	Sport City Cube	VB	08-	MST 409				260	MST 253				220
	300	Sport Cube Blackline		11	MST 409				260	MST 253				220
SR	300	Max ie		11-	MST 393				260	MST 395				240
	400	Scarabeo ie	VR	07-08	MST 409				260					
	500	Atlantic	VL	02-08	MST 409				260					
	500	Scarabeo ABS	VR	03-06	MST 409				260					
	500	Scarabeo ie	VR	07-09	MST 409				260					
SXV	450		VS	05-	MSW 270 RAC				320					
SXV	550		VS	05-	MSW 270 RAC				320					
	600	Pegaso	EP/FP	89-91	MST 337				298					



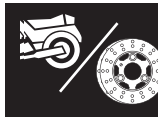
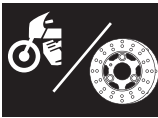
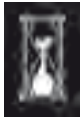

→ APRILIA

	650	Pegaso	GA	91-95	MST 337			298		
	650	Pegaso	ML/MX	96-04	MST 337			298		
	650	Pegaso Trial	VD	05-08	MST 337			298		
	650	Pegaso Strada	VD	05-06	MSW 211	*	RAC	320		
SMV	750	Dorsoduro, ABS	SM	09-	MSW 211	*	RAC	320	MST 430	245
SL	750	Shiver	RA	08-10	MSW 211	*	RAC	320	MST 376 RAC	220
SL	750	Shiver, ABS	RA	11-	MSW 211	*	RAC	320	MST 430	240
NA	850	Mana, ABS	RC	08-09	MSW 211	*	RAC	320	MST 376 RAC	220
NA	850	Mana GT, ABS	RC	10-	MSW 211	*	RAC	310	MST 431	260
SRV	850	, ABS		12-	MST 458	*		300	MST 459	280
RST	1000	Futura	PW	01-	MSW 221	*	RAC	298		
RSV	1000	Mille	ME	98-99	MSW 211	*	RAC	320	MST 376 RAC	220
RSV	1000	Mille, R Mille	RP	00-03	MSW 211	*	RAC	320	MST 376 RAC	220
RSV	1000	R, R Factory	RR	04-08	MSW 211	*	RAC	320	MST 376 RAC	220
RSV4	1000	R, Factory	RK	09-10	MSW 211	*	RAC	320	MST 376 RAC	220
RSV4	1000	R, Factory APRC, ABS	RK	11-	MSW 211	*	RAC	320	MST 429 RAC	220
RSV	1000	R Touno fighter	RP	02-06	MSW 211	*	RAC	320	MST 376 RAC	220
RSV	1000	Touno Racing, Factory	RR	06-10	MSW 211	*	RAC	320	MST 376 RAC	220
RSV4	1000	R, Tuono APRC	RK	11-	MSW 211	*	RAC	320	MST 376 RAC	220
SL	1000	Falco	PA	00-	MSW 211	*	RAC	320	MST 376 RAC	220
SMV	1200	Dorsoduro, ABS	TV	11-	MSW 211	*	RAC	320	MST 430	245

Arctic Cat

DVX	50		DVX50	06-	MST 256			180	MST 256	180
DVX	90		DVX90	06-	MST 256			180	MST 256	180

Atala

	50	Hacker		97-	MST 252		RAC	190	MST 252	RAC	190
--	----	--------	--	-----	----------------	--	------------	------------	----------------	------------	------------

Benelli

	50	Naked	ND	02-03	MST 252		RAC	190	MST 252	RAC	190
	50	Pepe LX		99-	MST 396			220			
491	50	RR, SBK	BA 01	00-	MST 252		RAC	190	MST 252	RAC	190
491	50	GP, Sport	BA 01	97-	MST 252		RAC	190	MST 252	RAC	190
K2	50		BA 01	98-01	MST 252		RAC	190	MST 252	RAC	190
K2	100		BA01	98-01	MST 252		RAC	190	MST 252	RAC	190
	100	Naked	ND	02-	MST 252		RAC	190	MST 252	RAC	190
	125	Adiva	D1	00-04	MST 254			220			
	125	Velvet	M1	99-07					MST 252	RAC	190
	150	Adiva	D1	00-04	MST 254			220			
BX	450			07-	MST 265		RAC	260	MST 266	RAC	220
	899	Century Racer		11-	MSW 211	*	RAC	320			
TNT	899	Sport	TN	08-	MSW 211	*	RAC	320			
TreK	899		TK	07-12	MSW 211	*	RAC	320			
	900	Tornado TRE	TB	02-	MSW 211	*	RAC	320			
	1130	Tornado TRE	TK	06-10	MSW 211	*	RAC	320			
	1130	TreK, Amazonas	TK	06-	MSW 211	*	RAC	320			
	1130	Century Racer		11-12	MSW 211	*	RAC	320			
TNT	1130	Cafe Racer	TN	05-11	MSW 211	*	RAC	320			
TNT	1130	Sport, Sport Evo	TN	05-09	MSW 211	*	RAC	320			

Beta

	50	Eikon	BS	99-06	MST 252		RAC	190	MST 252	RAC	190
	50	Quadra	KTM GO 50	97-00	MST 252		RAC	190	MST 252	RAC	190
	50	Chrono	KTM GO 50	94-	MST 236		RAC	190			
	50	Tempo 13	KTM GO 50	95-02	MST 252		RAC	190	MST 252	RAC	190
	50	ARK AC	BS	96-	MST 252		RAC	190			
	50	ARK LC	BS	97-	MST 252		RAC	190	MST 252	RAC	190
	125	Eikon	S7	99-	MST 254			220			
	150	Eikon	S7	99-	MST 254			220			

Bimota

	500	V-Due	VT5	97-	MSW 211		RAC	320			
	650	Supermono	BB1	96-	MSW 211		RAC	320			
	851	Tesi	T1D	90-91	MSW 211		RAC	320			
	900	Mantra	DB3	96-	MSW 211	*	RAC	320			
	900	DB4	DB4	98-99	MSW 211	*	RAC	320			
DB2	904	SR	DB2	94-00	MSW 211		RAC	320			
DB6	1000	R	DB06	08-	MSW 211	*	RAC	320			
	1000	Dieci Biposto	YB8	92-95	MSW 211		RAC	320			
SB 8-R	1000		SB8R	97-	MSW 211	*	RAC	320			





→ **BIMOTA**

DB7	1098	DB07	08-	MSW 211	*	RAC	320				
SB6	1100	SB6	96-	MSW 211	*	RAC	320				
SB6-R	1100	SB6R	98-	MSW 211	*	RAC	320				
DB8	1198	DB08	12-	MSW 211	*	RAC	320				
DB11	1198		13-	MSW 211	*	RAC					

BMW

G	450	X	E45X	08-	MST 418 RAC					260				
C	600	Sport ABS	K18	11-	MST 456					270	MST 456			270
C	650	GT ABS	K19	11-	MST 456					270	MST 456			270
F	650	, ABS	E169	94-00	MST 337					298	MST 330			240
F	650	ST	E169	96-00	MST 387					298	MST 330			240
F	650	CS	E169	93-00	MST 337		RAC			298	MST 330			240
F	650	CS, ABS	K14	00-05	MST 337		RAC			298	MST 330			240
F	650	CS, ABS	E650C	03-06	MST 337		RAC			298	MST 330			240
F	650	GS Dakar	R13	99-07	MST 337		RAC			298	MST 330			240
F	650	GS Dakar, ABS	E650G	04-07	MST 337		RAC			298	MST 330			240
G	650	GS, ABS	R13	09-	MST 337		RAC			298	MST 330			240
G	650	GS Sertao, ABS	R13	12-	MSW 253					300	MST 330			240
G	650	X Challenge	E65X	06-07	MST 337		RAC			298				
G	650	X Country	E65X	07-09	MST 337		RAC			298				
G	650	X Moto	E65X	06-07	MSW 211		RAC			320	MST 330			240
F	700	GS ABS	E8GS	13-	MSW 253	*				300	MST 372	RAC		265
F 650	798	GS Dakar, ABS	E8GS	06-12	MST 337		RAC			298	MST 372	RAC		265
F	800	GS, ABS	E8GS	08-	MSW 253	*				300	MST 372	RAC		265
F	800	GT ABS	E8ST	13-	MST 357	*	RAC	FS		320	MST 372	RAC		265
F	800	R, ABS	E8ST	09-	MST 356	*	RAC			320	MST 372	RAC		265
F	800	S, ST, ABS	E8ST	04-10	MST 356		RAC			320	MST 372	RAC		265
R	850	C	E259C	97-00	MST 239	*	RAC	FS		305				
R	850	C, ABS	E259C	97-00	MST 239	*	RAC			305				
R	850	GS, ABS	E259	96-97	MST 239	*	RAC	FS		305	MST 331	RAC		276
R	850	GS, ABS	R 21	98-00	MST 239	*	RAC	FS		305	MST 331	RAC		276
R	850	RT, ABS	E259	95-01	MSW 200	*				305	MST 331	RAC		276
R	850	RT (Integral ABS)	R22	01-06	MST 357	*	RAC	FS		320				
R	850	R, ABS (Cast wheel)	E259	93-00	MSW 200	*				305				
R	850	R (Spoke wheel)	E259	94-96	MST 239	*	RAC			305	MST 331	RAC		276
R	850	R, ABS	R21	00-03	MST 239	*	RAC	FS		305	MST 331	RAC		276
R	850	R Comfort, ABS	R11R	04-07	MST 357	*	RAC	FS		320	MST 331	RAC		276
K 1	1000		BMW 100	89-93	MSW 200	*				305				
K 100	1000	RS 16V, auch ABS	BMW 100	89-92	MSW 200	*				305				
S	1000	RR	K10	09-	MST 357	*	RAC	FS		320	MST 392	RAC		220
K	1100	RS, LT mit ABS	BMW 100	89-99	MSW 200	*				305				
R	1100	GS,	E259	94-99	MST 239	*	RAC	FS		305	MST 331	RAC		276
R	1100	GS, ABS	E259	94-99	MST 239	*	RAC			305	MST 331	RAC		276
R	1100	S, ABS	R2S	98-03	MST 239 FS	*				305	MST 331	RAC		276
R	1100	S, ABS	R2S	98-03	MST 238	*	RAC			305	MST 331	RAC		276
R	1100	S, Integral ABS	R2S	01-03	MST 357	*	RAC	FS		320	MST 331	RAC		276
R	1100	S, Integral ABS	R11S	04-05	MST 357	*	RAC	FS		320	MST 331	RAC		276
R	1100	RS, ABS	E259	92-01	MSW 200	*				305				
R	1100	R, ABS	E259R	93-01	MSW 200	*				305	MST 331	RAC		276
R	1100	RT, ABS	E259	94-01	MSW 200	*				305	MST 331	RAC		276
R	1150	GS (Evo/ABS)	R21	98-03	MST 238	*	RAC			305	MST 331	RAC		276
R	1150	GS (Evo/ABS)	R11R	04-05	MST 239 FS	*				305	MST 331	RAC		276
R	1150	GS (Evo/ABS)	R11R	04-05	MST 238	*	RAC			305	MST 331	RAC		276
R	1150	GS Adventure (Evo/ABS)	R21/R11R	02-05	MST 239 FS	*				305	MST 331	RAC		276
R	1150	GS Adventure (Evo/ABS)	R21/R11R	02-05	MST 238	*	RAC			305	MST 331	RAC		276
R	1150	R, R Rockster	R21	00-03	MST 357	*	RAC	FS		320	MST 331	RAC		276
R	1150	R, R Rockster	R11R	04-06	MST 357	*	RAC	FS		320	MST 331	RAC		276
R	1150	RT (Integral ABS)	R22	00-03	MST 357	*	RAC	FS		320	MST 331	RAC		276

		Stärke / thickness	OE Ausführung / OE finish		Montagezubehör / fittingkits	
MST238 / MST356 (RAC)		4,5 mm	verschraubt / loose bobbins	- 11/07	OE, optional MST13FK	OE
MST238 / MST356 (RAC)		4,5 mm	vernietet / fixed bobbins	12/07 -	MST14FK	OE
MST239 / MST357 (RAC)		5 mm	verschraubt / loose bobbins	- 11/07	OE, optional MST15FK	OE
MST239 / MST357 (RAC)		5 mm	vernietet / fixed bobbins	12/07 -	MST16FK	OE
MST239FS / MST357FS		5 mm	verschraubt / loose bobbins	- 11/07	nicht nötig / not necessary	OE
MST239FS / MST357FS		5 mm	vernietet / fixed bobbins	12/07 -	MST12FK	OE

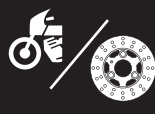

→ BMW

R	1150	RT (Intergral ABS)	R11RT	04-06	MST 357	*	RAC	FS	320	MST 331	RAC	276
R	1150	RS (Intergral ABS)	R22	00-04	MST 357	*	RAC	FS	320	MST 331	RAC	276
R	1150	RS (Intergral ABS)	R11RT	04	MST 357	*	RAC	FS	320	MST 331	RAC	276
K	1200	GT	K12/K12S	02-08	MST 357	*	RAC	FS	320	MST 391		294
K	1200	LT, auch ABS	K2LT	98-99	MST 239	*	RAC	FS	305			
K	1200	LT (Evo-Intergral ABS)	K2LT	99-09	MST 357	*	RAC	FS	320			
K	1200	RS, ABS	BMW589	97-00	MST 238	*	RAC		305			
K	1200	RS, Intergral ABS	K12	00-05	MST 357	*	RAC	FS	320			
K	1200	S	K12S	03-08	MST 357	*	RAC	FS	320	MST 372	RAC	265
K	1200	R	K12R	04-08	MST 357	*	RAC	FS	320	MST 372	RAC	265
R	1200	C	BMW259C	97-01	MST 239	*	RAC	FS	305			
R	1200	C ABS	BMW259C	97-00	MST 239	*	RAC		305			
R	1200	C	R2C	01-04	MST 239	*	RAC	FS	305			
R	1200	C ABS	R2C	01-04	MST 239	*	RAC		305			
R	1200	CL, ABS	K30	03-04	MST 239	*	RAC	FS	305			
R	1200	GS, ABS	R12	03-12	MST 239 FS	*			305	MST 372 RAC		265
R	1200	GS, ABS	R12	03-12	MST 238	*	RAC		305	MST 372	RAC	265
R	1200	GS Adventure ABS	R12	05-12	MST 239 FS	*			305	MST 372 RAC		265
R	1200	GS Adventure ABS	R12	05-12	MST 238	*	RAC		305	MST 372	RAC	265
R	1200	GS ABS, GS Adventure ABSR12W		13-	MST 238	*	RAC		305	MST 464	RAC	276
R	1200	GS ABS, GS Adventure ABSR12W		13-	MST 239 FS	*			305	MST 464 RAC		276
R	1200	HP2 Enduro	RHP2	04-06	MST 239	*	RAC	FS	305	MST 372	RAC	265
R	1200	HP2 Megamoto	RHP2	07-08	MST 357 FS	*			320	MST 372	RAC	265
R	1200	HP2 Megamoto	RHP2	07-08	MST 356	*	RAC		320	MST 372	RAC	265
R	1200	HP2 Sport	R12S	08-10	MST 357 FS	*			320	MST 372	RAC	265
R	1200	HP2 Sport	R12S	08-10	MST 356	*	RAC		320	MST 372	RAC	265
R	1200	RT, ABS	R12T	03-	MST 357 FS	*			320	MST 372	RAC	265
R	1200	RT, ABS	R12T	03-	MST 356	*	RAC		320	MST 372	RAC	265
R	1200	R, Classic, ABS	R1ST	05-	MST 357 FS	*			320	MST 372	RAC	265
R	1200	R, Classic, ABS	R1ST	05-	MST 356	*	RAC		320	MST 372	RAC	265
R	1200	S, ABS	R12S	04-06	MST 357 FS	*			320	MST 372	RAC	265
R	1200	S, ABS	R12S	04-06	MST 356	*	RAC		320	MST 372	RAC	265
R	1200	ST, ABS	R1ST	03-07	MST 357 FS	*			320	MST 372	RAC	265
R	1200	ST, ABS	R1ST	03-07	MST 356	*	RAC		320	MST 372	RAC	265
K	1300	GT ABS	K12S	07-	MST 357	*	RAC	FS	320	MST 391		294
K	1300	R, S ABS	K12S	07-	MST 357	*	RAC	FS	320	MST 372	RAC	265
K	1600	GT, GTL ABS	K16GT	11-	MST 357	*	RAC	FS	320			

Bombardier

DS	650	Baja	A	00-06	MST 400				165	MST 401		196
----	-----	------	---	-------	---------	--	--	--	-----	---------	--	-----

Cagiva

	50	City	4P	07-	MST 243		RAC			190		
	50	City Scooter	4P	92-	MST 241					162		
	110	Passing	6P	94-	MST 241					162		
	125	Freccia	C12	89-91	MSW 221		RAC			300		
	125	Mito	8P	91-93	MSW 211		RAC			320		
	125	Mito EV	8P	95-	MSW 211		RAC			320		
	125	Mito SP525	N3	07-	MSW 211		RAC			320		
	125	Raptor	N3	03-	MSW 211		RAC			320		
	125	Supercity	2F	92-	MSW 211		RAC			320		
N1	125	Planet	N1	97-	MSW 211		RAC			320		
	500	Canyon		96-00	MST 206					296		
	600	Canyon	5G1	96-99	MST 206					296		
	500	Mito		07-	MSW 211		RAC			320		
	600	River	3G	94-	MSW 211	*	RAC			320		
	750	Elefant	B	94-97	MST 206		RAC			296		
	900	Elefant I.E.	B	90-92	MST 206		RAC			296		
	900	Canyon	G	97-99	MST 206	*	RAC			296		
	1000	Navigator	M5	00-	MST 206	*	RAC			296		
	1000	Raptor X3	M2	03-04	MSW 211	*	RAC			320		

CPI

	50	Baby		02-	MST 243		RAC			190		
	50	Popcorn	JP	02-	MST 243		RAC			190		
	50	Oliver	JR	03-	MST 243		RAC			190		
	50	Hussar	JR	03-	MST 243		RAC			190		

Derbi

	50	Atlantis 4T	AL	04-	MST 260		RAC			200		
	50	Boulevard		09-	MST 260		RAC			200		
	50	GP-1	PR	05-	MST 255				174	MST 255		174





→ DERBI

	50	GP Open	GR	06-	MST 396			220	MST 255		174
	50	Hunter	HUNT	97-	MST 243	RAC		190			
	50	Paddock LC	HUNT	96-	MST 243	RAC		190			
	50	Predator	PRED	98-	MST 243	RAC		190			
	100	Predator	PRED	98-	MST 243	RAC		190			
	125	Boulevard	BL	03-07	MST 254			220			
	125	Boulevard S	M57	07	MST 409			260			
	125	Boulevard 4T	M57	08-	MST 260	RAC		200			
	125	Rambla	RA	08-	MST 409			260			
	150	Boulevard		03-09	MST 254			220			
	200	Boulevard		05	MST 254			220			
	250	/300 Rambla i	RA	08-	MST 409			260			
DXR	200			04-	MST 405			161	MST 407		220
DXR	250			04-	MST 405			161	MST 407		220

Ducati

	400	Monster		00-04	MSW 211	RAC		320	MST 247	RAC	245
	400	Monster Dark i.e.		05-06	MSW 211	RAC		320	MST 247	RAC	245
	400	SS	S	93-97	MSW 211	RAC		320	MST 247	RAC	245
	600	SS	ZDM600S...	94-	MSW 211	RAC		320	MST 247	RAC	245
	600	Monster	M	94-01	MSW 211	RAC		320	MST 247	RAC	245
	620	Monster i.e., Dark	M4	02-04	MSW 211	RAC		320	MST 247	RAC	245
	620	Sport	V5	03-	MSW 211	RAC		320	MST 247	RAC	245
	695	Monster	M4	06-	MSW 211	*	RAC	320	MST 247	RAC	245
	696	Monster, ABS	M5	08-	MSW 211	*	RAC	320	MST 247	RAC	245
	748	SP	ZDM 748S...	95-96	MSW 211	*	RAC	320			
	748	Biposto	748	95-98	MSW 211	*	RAC	320			
	748	Biposto	H3	99-02	MSW 211	*	RAC	320			
	748	SPS, R	ZDM 748S...	98-02	MSW 211	*	RAC	320			
	749	, R, S		02-07	MSW 267 RAC	*		320	MST 419 RAC		240
	750	Sport	ZDM750S...	01-02	MSW 211	*	RAC	320	MST 247	RAC	245
	750	SS	S	91-	MSW 211	*	RAC	320	MST 247	RAC	245
	750	Monster, Monster i.e.	M	96-02	MSW 211	*	RAC	320	MST 247	RAC	245
	796	Hypermotard	B1	11-12	MSW 281 RAC	*		305	MST 377 RAC		245
	796	Monster, ABS	M5	11-	MSW 285 RAC	*		320	MST 420 RAC		245
	800	Monster	M	03-04	MSW 211	*	RAC	320	MST 247	RAC	245
	800	SS, Sport	V5	03-05	MSW 211	*	RAC	320	MST 247	RAC	245
	821	Hypermotard, SP ABS		13-	MSW 281 RAC	*			MST 377 RAC		245
	848		H6	08-10	MSW 267 RAC	*		320	MST 377 RAC		245
	848	Evo, Evo Dark	H6	10-	MSW 267 RAC	*		320	MST 377 RAC		245
	848	Streetfighter		11-	MSW 285 RAC	*		320	MST 377 RAC		245
	851	Strada, Sp	ZDM851S3...	90-91	MSW 211	*	RAC	320	MST 247	RAC	245
	851	UPS	ZDM851S3...	92-	MSW 211	*	RAC	320			
	888	SPS	ZDM888S...	90-93	MSW 211	*	RAC	320	MST 247	RAC	245
	888	SP4/SP5	ZDM888S...	91-	MSW 211	*	RAC	320			
	888	Desmo4	ZDM888S...	93-94	MSW 211	*	RAC	320	MST 247	RAC	245
	900	Sport SS i.e.	V1	02	MSW 211	*	RAC	320	MST 247	RAC	245
	900	SS	S	91-	MSW 211	*	RAC	320	MST 247	RAC	245
	900	SL	ZDM906SC2...	92-96	MSW 211	*	RAC	320	MST 247	RAC	245
	900	Monster, Monster i.e.	M	93-01	MSW 211	*	RAC	320	MST 247	RAC	245
S4	916	Monster	M4	01-02	MSW 211	*	RAC	320	MST 247	RAC	245
	916	SP	916	94-97	MSW 211	*	RAC	320			
	916	Strada	916	94-98	MSW 211	*	RAC	320			
	916	SPS	916	98-	MSW 211	*	RAC	320			
	916	ST4	S2	99-02	MSW 211	*	RAC	320	MST 247	RAC	245
	944	ST2	S1	97-03	MSW 211	*	RAC	320	MST 247	RAC	245
	989	Desmosedici RR		08-09	MSW 280 RAC	*		330	MST 377 RAC		245
	992	ST3	S3	04-	MSW 211	*	RAC	320	MST 247	RAC	245
	996	R	H2	01	MSW 211	*	RAC	320			
	996	S	H1	01	MSW 211	*	RAC	320			
	996	ST4 S	S2	01-05	MSW 211	*	RAC	320	MST 247	RAC	245
	996	SPS, Biposto	H2	99-01	MSW 211	*	RAC	320			
S4R	996	Monster	M4	01-05	MSW 211	*	RAC	320	MST 377 RAC		245
S4R	998	Monster S4R-S	M4	07-	MSW 267 RAC	*		320	MST 377 RAC		245
	998	Biposto	916	02	MSW 211	*	RAC	320			
	998	R	H2	02-	MSW 211	*	RAC	320			
	998	S	H2	02-	MSW 211	*	RAC	320			
	999	Biposto	H4	02-	MSW 267 RAC	*		305	MST 419 RAC		240
	999	R, S	H4	02-06	MSW 267 RAC	*		320	MST 419 RAC		240
	1000	Monster i.e., S i.e., Dark	M4	03-06	MSW 211	*	RAC	320	MST 247	RAC	245



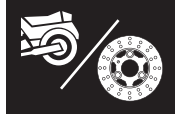
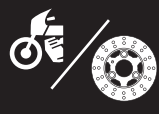

→ DUCATI

S2R	1000	Monster	M4	07-08	MSW 211	*	RAC	320	MST 377 RAC	245
S2R	1000	Monster	M4	09-	MSW 267 RAC	*		320	MST 377 RAC	245
	1000	Sport Classic, S Sport	C1	05-09	MSW 211	*	RAC	320	MST 247	RAC 245
	1000	SS	V5	03-06	MSW 211	*	RAC	320	MST 247	RAC 245
GT	1000	, Touring	C1	06-	MSW 211	*	RAC	320	MST 247	RAC 245
	1098	R	H7	07-	MSW 280 RAC	*		330	MST 461 RAC	245
	1100	Hypermotard Evo/SP	B1	07-12	MSW 281 RAC	*		305	MST 377 RAC	245
	1100	Monster, ABS	M5	09-10	MSW 285 RAC	*		320	MST 420 RAC	245
	1100	Monster S, S ABS	M5	09-10	MSW 267 RAC	*		320	MST 420 RAC	245
	1100	Monster Evo ABS, Diesel	M5	11-	MSW 285 RAC	*		320	MST 420 RAC	245
	1100	Multistrada		03-09	MSW 281 RAC	*		305	MST 377RAC	245
	1100	Streetfighter, S	F1	10-	MSW 267 RAC	*		320	MST 461 RAC	245
	1100	Streetfighter, S ABS	F1	11-	MSW 280 RAC	*		330	MST 461 RAC	245
	1198			09-11	MSW 280 RAC	*			MST 461 RAC	245
	1198	S, R, SP	H7	10-	MSW 280 RAC	*		330	MST 461 RAC	245
	1198	Diavel, Carbon, Dark, Strada		12-	MSW 285 RAC	*		320		
	1199	Panigale, S, Tricolore, ABS		12-	MSW 280 RAC	*		330		
	1200	Multistrada, S	A2	10-	MSW 285 RAC	*		320	MST 377 RAC	245
	1200	Multistrada, S, ABS	A2	10-	MSW 285 RAC	*		320	MST 420 RAC	245

Fantic

	50	Big wheels		93-94	MST 250			155		
	50	Pony		93-95	MST 250			155		
	50	Grinta		95-	MST 250			155		
	50	Queenie		95-	MST 250			155		

Garelli

	50	Big wheels		91-94	MST 250			155		
	50	Pony SR		92-95	MST 250			155		
	50	Bip-Racing		94-	MST 250			155		
	50	Grinta		95	MST 250			155		

Gas Gas

	80	MC		95-02	MST 303			260		
	125	EC	VTREC125...	95-	MST 303			260		
	125	MC		95-	MST 303			260		
	200	EC, MC	VTREC200...	99-	MST 303			260		
	250	EC, MC	VTREC250...	95-	MST 303			260		
	300	EC, MC	VTREC300...	99-	MST 303			260		
EC	400	FSE	FS	02-					MST 266	RAC 220
	400	EC, MC, 4-T	VTREC400...	02-03	MST 303			260		
	450	EC, MC, 4-T	FS	03-	MST 303			260		
	515	EC, MC, 4-T		08-10	MST 303			260		

Generic

	50	Cracker		09-	MST 243		RAC	190		
	50	Ideo	B93	05-	MST 243		RAC	190		
	50	Sirion		12-	MST 243		RAC	190		
	50	Trigger	D01	02-	MST 243		RAC	190		
	50	XOR	BN0T	05-	MST 243		RAC	190		
GT	50	Race Explorer		09	MST 256			180		
	125	Sirion		12-	MST 243		RAC	190		
	125	XOR	TEJ5	05-	MST 243		RAC	190		

Gilera

	50	DNA	C27	00-				MST 260	RAC	200
	50	Ice	C30	01-03	MST 260		RAC	200		
	50	NRG	C18	94-	MST 236		RAC	190		
	50	Purejet		98-05	MST 254			220	MST 255	174
	50	Storm	TEC	94-95	MST 236		RAC	190		
	50	Stalker	C13	97-11	MST 236		RAC	190	MST 255	174
FX	50	Runner SP	C14	97-05	MST 254			220	MST 255	174
SP	50	Runner Pure Jet	C46	06-	MST 396			220	MST 255	174
TPH	50	Typhoon	TEC	93-	MST 236		RAC	190		
	50	Easy Moving		95-96	MST 250			155		
	125	Coguar	M17	99-02	MST 393			260		
	125	Nexus	M35	07-	MST 393			260	MST 395	240
FX	125	Runner	M07	97-02	MST 254			220	MST 236	RAC 190
FXR	125	Runner SP	M07	99-	MST 254			220		
TPH	125	Typhoon	M02	96-	MST 236		RAC	190		
VX	125	Runner	M24	01-04	MST 254			220	MST 260	RAC 200
VX	125	Runner, ST	M46	05-	MST 394			240	MST 396	220





→ GILERA

VXR	125	Runner	M24	01-	MST 254		220	MST 260	RAC	200
FXR	180	Runner	M08	97-02	MST 254		220	MST 236	RAC	190
FXR	180	Runner SP	M08	99-	MST 254		220			
VXR	180	Runner	M08	01-04	MST 254		220	MST 260	RAC	200
VXR	200	Runner	M24	02-04	MST 254		220	MST 396		220
VX	200	Runner, ST	M46	05-11	MST 394		240	MST 396		220
	250	Nexus, ie	M35	06-08	MST 393		260	MST 395		240
	300	Nexus, ie	M35	08-	MST 393		260	MST 395		240
	500	Nexus, SP	M35	04-	MST 393	*	260	MST 395		240
RC	500	Fuoco i.e.	M61	07-	MST 394	*	240	MST 395		240
GP	800			08-	MST 458	*	300	MST 459		280

Harley Davidson

XL	883	C Sportster Custom		00-10	MST 500	SWL	292	MST 501	SWL	292
XL	883	L Sportster Low		07-10	MST 500	SWL	292	MST 503	SWL	260
XL	883	L Sportster Superlow		11-	MST 500	SWL	292	MST 503	SWL	260
XL	883	N Sportster Iron		09-	MST 500	SWL	292			
XL	883	R Roadster ←		10-	MST 500	SWL	292	MST 503	SWL	260
XL	883	R Roadster →		10-	MST 500	SWR	292			
XL	883	R Sportster ←		00-03	MST 500	SWL	292	MST 503	SWL	260
XL	883	R Sportster →		00-03	MST 500	SWR	292			
XLH	883	Sportster		00-06	MST 500	SWL	292	MST 501	SWL	292
XLH	883	Sportster Hugger		00-03	MST 500	SWL	292	MST 501	SWL	292
XL	1200	C Sportster Custom		04-	MST 500	SWL	292	MST 501	SWL	292
XL	1200	L Sportster Low		07-10	MST 500	SWL	292	MST 503	SWL	260
XL	1200	N Nightster		07-12	MST 500	SWL	292	MST 503	SWL	260
XL	1200	R Sportster Roadster ←		04-08	MST 500	SWL	292	MST 501	SWL	292
XL	1200	R Sportster Roadster →		04-08	MST 500	SWR	292			
XL	1200	S Sportster Sport		00-03	MST 500	SWL	292	MST 501	SWL	292
XL	1200	X Forty-Eight		10-	MST 500	SWL	292	MST 501	SWL	292
FLSTC	1340	Heritage Softail Classic		00-02	MST 500	SWL	292	MST 501	SWR	292
FLHR	1450	Road King ←		00-06	MST 500	SWL	292	MST 501	SWR	292
FLHR	1450	Road King →		00-06	MST 500	SWR	292			
FLHRCI	1450	Road King Classic ←		00-06	MST 500	SWL	292	MST 501	SWR	292
FLHRCI	1450	Road King Classic →		00-06	MST 500	SWR	292			
FLHRS/I	1450	Road King Custom ←		00-06	MST 500	SWL	292	MST 501	SWR	292
FLHRS/I	1450	Road King Custom →		00-06	MST 500	SWR	292			
FLHT/I	1450	Electra Glide Standard ←		00-06	MST 500	SWL	292	MST 501	SWR	292
FLHT/I	1450	Electra Glide Standard →		00-06	MST 500	SWR	292			
FLHTCUI	1450	Electra Glide Ultra Classic ←		00-06	MST 500	SWL	292	MST 501	SWR	292
FLHTCUI	1450	Electra Glide Ultra Classic →		00-06	MST 500	SWR	292			
FLSTC	1450	Heritage Softail Classic		00-06	MST 500	SWL	292	MST 501	SWR	292
FLSTF	1450	Fat Boy		00-06	MST 500	SWL	292	MST 501	SWR	292
FLSTI/C	1450	Heritage Classic, Softail C.		00-06	MST 500	SWL	292	MST 501	SWR	292
FLSTS/I	1450	Heritage Springer		00-03	MST 500	SWL	292	MST 501	SWR	292
FLTR/I	1450	Road Glide Classic ←		00-06	MST 500	SWL	292	MST 501	SWR	292
FLTR/I	1450	Road Glide Classic →		00-06	MST 500	SWR	292			
FXD	1450	Super Glide		00-03	MST 500	SWL	292	MST 501	SWR	292
FXD/I	1450	Dyna Super Glide		00-06	MST 500	SWL	292	MST 501	SWR	292
FXDCI	1450	Dyna Super Glide Custom		05	MST 500	SWL	292	MST 501	SWR	292
FXDL/I	1450	Low Rider ←		00-05	MST 500	SWL	292	MST 501	SWR	292
FXDL/I	1450	Low Rider →		00-05	MST 500	SWR	292			
FXDS	1450	Dyna Convertible ←		00-02	MST 500	SWL	292	MST 501	SWR	292
FXDS	1450	Dyna Convertible →		00-02	MST 500	SWR	292			
FXDWG	1450	Dyna Wide Glide		00-05	MST 500	SWL	292	MST 501	SWR	292
FXDX/I	1450	Dyna Super Glide Sport, T-sport ←		00-06	MST 500	SWL	292	MST 501	SWR	292
FXDX/I/T	1450	Dyna Super Glide Sport, T-sport →		00-06	MST 500	SWR	292			
FXSTB	1450	Softtail Standard		00-06	MST 500	SWL	292	MST 501	SWR	292
FXSTB/I	1450	Night Train		00-06	MST 500	SWL	292	MST 501	SWR	292
FXSTD	1450	Softtail Deuce		00-06	MST 500	SWL	292	MST 501	SWR	292
FLHRC	1584	Road King, Road King Classic ←		07	MST 500	SWL	292	MST 501	SWR	292
FLHRC	1584	Road King, Road King Classic →		07	MST 500	SWR	292			
FLHT/I	1584	Electra Glide Classic, Ultra C. ←		07	MST 500	SWL	292	MST 501	SWR	292
FLHT/I	1584	Electra Glide Classic, Ultra C. →		07	MST 500	SWR	292			
FLHX	1584	Street Glide ←		06-07	MST 500	SWL	292	MST 501	SWR	292
FLHX	1584	Street Glide →		06-07	MST 500	SWR	292			
FLSTC	1584	Heritage Softail Classic		07-11	MST 500	SWL	292	MST 501	SWR	292
FLSTF/B	1584	Fat Boy, Fat Boy Special		07-11	MST 500	SWL	292	MST 501	SWR	292
FLSTN	1584	Softail Deluxe		07-11	MST 500	SWL	292	MST 501	SWR	292
FLSTSB	1584	Cross Bones		08-11	MST 500	SWL	292	MST 501	SWR	292
FXCW	1584	Rocker, Rocker C		08-11	MST 500	SWL	292	MST 501	SWR	292



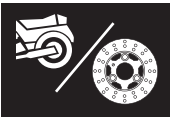
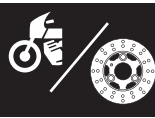
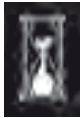

→ HARLEY DAVIDSON

FXS	1584	Black Line		11-	MST 500	SWL	292	MST 501	SWR	292		
FXSTB	1584	Night Train		07-09	MST 500	SWL	292	MST 501	SWR	292		
FXSTBIC	1584	Night Creeper		07-	MST 500	SWL	292	MST 501	SWR	292		
FXSTC	1584	Softail Custom		07-09	MST 500	SWL	292	MST 501	SWR	292		
FLS	1690	Softail Slim		12-	MST 500	SWL	292	MST 501	SWR	292		
FLSTC	1690	Heritage Softail Classic		12-	MST 500	SWL	292	MST 501	SWR	292		
FLSTF	1690	Fat Boy, Fat Boy Special		12-	MST 500	SWL	292	MST 501	SWR	292		
FLSTN	1690	Softail Deluxe		12-	MST 500	SWL	292	MST 501	SWR	292		
Honda												
GP	50	Scooter		90-	MST 241		162					
HSC	50	ZR	AF37	92-	MST 241		162					
HSC	50	1	AF37	93-	MST 241		162					
MTX	50		AD04		MST 300		240					
NSC	50	„C Vision 14“		11-	MST 452		190					
NSC	50	„AC Vision 16“		11-	MST 452		190					
SFX	50		AF32	95-04	MST 241		160					
SXR	50		AF18	98-99	MST 241		160					
SGX	50	sky	AF43	97-	MST 243	RAC	190					
SJ	50	Bali	AF32	93-99	MST 243	RAC	190	MST 252	RAC	190		
SK	50	Dio Scooter	AF18	90-	MST 241		162					
ZX	50	ZX	SC01	94-	MST 241		162					
	50	Yupi		90-	MST 243	RAC	190					
CR	80	R	HE02	92-95				MST 324	EC	190		
CR	80	R	HE04	96-02	MST 302	EC	220	MST 324	EC	190		
MTX	80		HD06		MST 300		240					
CR	85	R	HE07	03-07	MST 302	EC	220	MST 324	EC	190		
SJ	100	Bali	HF07	95-99	MST 243	RAC	190	MST 252	RAC	190		
NSC	110	„C Vision 14“		11-	MST 452		190					
NSC	110	„AC Vision 16“		11-	MST 452		190					
SCV	110	Lead		08-09	MST 243	RAC	190					
SCV	110	Lead		10-	MST 452		190					
CH	125	Spacy	JF03	98-	MST 243	RAC	190					
CBR	125		JC34	04-07	MST 205		276	MST 245	RAC	220		
CBR	125	R	JC39	08-	MST 205		276	MST 245	RAC	220		
CR	125		JE01	89-91				MST 321		220		
CR	125		JE01	92-94	MST 300		240	MST 321		220		
CR	125		JE01	95-97	MST 301	RAC	EC	240	MST 321	220		
CR	125		JE01	98-01	MST 301	RAC	EC	240	MST 322	240		
CR	125		JE01	02-03	MST 301	RAC	EC	240	MST 328	RAC	EC	240
CR	125		JE01	04-	MST 301	RAC	EC	240	MST 328	RAC	EC	240
FES	125	Pantheon Scooter	JF05	98-02	MST 453		240					
FES	125	Pantheon Scooter	JF12	03-06	MST 453		240	MST 245	RAC	220		
FES	125	S-Wing, ABS		07-	MST 453		240					
PCX	125			10-	MST 452		220					
RS	125	R	JF05	91-03	MSW 212	RAC	296					
SH	125	i		09-	MST 453		240	MST240	RAC	240		
XL	125	R	KF06		MST 300		240					
XLV	125	Varadero	JC32	01-	MST 424		276					
CRF	150		CRF150	07-12	MST 302	EC	220	MST 324	EC	190		
FES	150	Pantheon Scooter	JF05	98-02	MST 453		240					
FES	150	Pantheon Scooter	KF06	03-06	MST 453		240	MST 245	RAC	220		
PCX	150			13-	MST 452		220					
SH	150	i		09-	MST 453		240	MST 240	RAC	240		
	250	Jazz	MF07	01-04	MST 240		240					
ATC	250		ATC250	85-88	MST 403		174					
CB	250	N	CB250N	82-88	MSW 212	RAC	296					
CB	250	Two Fifty	MC26	92-	MST 240	RAC	240					
CB-F	250	Hornet	MC31	97-	MSW 212	RAC	296	MST 245	RAC	220		
CBR	250	R		11-	MSW 272		296	MST 245	RAC	220		
CBR	250	R ABS		11-	MSW 272		296	MST 455		220		
CR	250		ME03	89-91				MST 321		220		
CR	250		ME03	92-94	MST 300		240	MST 321		220		
CR	250		ME03	95-97	MST 301	RAC	EC	240	MST 321	220		
CR	250		ME03	98-01	MST 301	RAC	EC	240	MST 322	240		
CR	250		ME03	02-03	MST 301	RAC	EC	240	MST 328	RAC	EC	240
CR	250		ME03	04-	MST 301	RAC	EC	240	MST 328	RAC	EC	240
CRF	250		ME11	04-	MST 301	RAC	EC	240	MST 328	RAC	EC	240
CRF	250	L		13-	MST 454		256	MST 245	RAC	240		
FES	250	Foresight	MF04	98-99	MST 453		240					
FES	250	Foresight	MF05	00-05	MST 453		240	MST 245	RAC	220		





→ **HONDA**

NSS	250	Forza	MF06	00-04	MST 453				240	MST 245	RAC	220
NSS	250	Forza ABS	HF08	05-06	MST 453				240	MST 240	RAC	240
PS	250	Big Ruckus	MF09	05-06	MST 453				240			
RS	250	R		90-97	MSW 212	*	RAC		296			
TRX	250	X	TE 13	87-92	MST 403				174			
TRX	250	EX	TRX250	01-	MST 403				174			
TSR	250		TSR250	99-	MSW 212		RAC		296			
VTR	250	F	MC15	98-						MST 245	RAC	220
XL	250	R	MD11	84-93	MST 300				240			
XL	250	R Baja	MD11	88-91	MST 300				240	MST 326		220
XR	250	RB	ME01	84-90	MST 300				240			
XR	250		ME06	91-03	MST 300				240	MST 323		220
SH	300	i, ABS		07-	MST 450				256	MST 373		256
TRX	300	EX Sporttrax	TE19	93-	MST 403				174	MST 404		220
CB	350	S-G (Schweden)	NC22	87-	MST 201				256			
XR	350		ND03	84-90	MST 300				240			
XR	350	RF	NE02		MST 300				240			
XR	350	RD	NE01	84-87	MST 300				240			
CB-1	400	F	NC27	89-91						MST 245	RAC	220
CBR	400	F-F2	NC23	85-87	MSW 212		RAC		296			
FJS	400	Silver Wing	NF01	06-08	MST 373		RAC		256			
RVF	400	RR	NC35	94-96	MSW 212	*	RAC		296			
TRX	400	EX Sporttrax	TE23	99-	MST 403				174	MST 323		220
VFR	400	R	NC24	87-88	MST 205	*			276			
VFR	400	R	NC30	89-	MSW 212	*	RAC		296			
XR	400	RT	NE03	96-03	MST 300				240	MST 323		220
CB	450	S	PC17	86-88	MST 201	*			256			
CRF	450	R	PE05	02-08	MST 301		RAC	EC	240	MST 328	RAC	EC 240
TRX	450	R, ER	TE22	04-	MST 403				174			
CB	500		PC26	94-96	MST 206		RAC		296			
CB	500	S	PC32	97-	MST 206		RAC		296	MST 240	RAC	240
CB	500	F, FA ABS	PC45	13-	MST 465 RAC					MST 338	RAC	240
CB	500	X, XA ABS	PC46	13-	MST 465 RAC					MST 338	RAC	240
CBF	500	, ABS	PC39	04-07	MST 206	*	RAC		296	MST 338	RAC	240
CBR	500	R, ABS	PC44	13-	MST 465 RAC					MST 338	RAC	240
CR	500	RE	PE02	89-91						MST 321		220
CR	500	RE	PE02	92-94	MST 300				240	MST 321		220
CR	500	RE	PE02	95-01	MST 301		RAC	EC	240	MST 321		220
XBR	500	, S	PC15	85-89	MST 202				276			
XR	500		PE03	83-86	MST 300				240			
CB	600	„Hornet (16“ „)“	PC34	98-99						MST 245	RAC	SL 220
CB	600	„Hornet (17“ „)“	PC34	00-01	MSW 243	*			296	MST 245	RAC	SL 220
CB	600	„Hornet (17“ „)“	PC36	02-06	MSW 243	*			296	MST 245	RAC	SL 220
CB	600	Hornet, ABS	PC41	07-	MSW 283 RAC	*			296	MST 338	RAC	240
CBF	600		PC38	04-07	MST 206	*	RAC		296	MST 338	RAC	240
CBF	600	N,S, ABS	PC43	08-	MSW 272	*			296	MST 338	RAC	240
CBR	600	F	PC19	87-88	MST 205	*			276			
CBR	600	F	PC23	89-90	MST 205	*			276			
CBR	600	F	PC25	91-94	MST 205	*			276	MST 245	RAC	SL 220
CBR	600	F	PC31	95-98	MSW 212	*	RAC		296	MST 245	RAC	SL 220
CBR	600	F	PC35	99-00	MSW 236	*			296	MST 245	RAC	SL 220
CBR	600	F	PC35	01-07	MSW 244	*	RAC		296	MST 245	RAC	SL 220
CBR	600	F, ABS		11-	MSW 283 RAC	*			296	MST 338	RAC	240
CBR	600	RR	PC37	03-06	MSW 240	*	RAC		310	MST 245	RAC	SL 220
CBR	600	RR	PC40	07-	MSW 240	*	RAC		310	MST 245	RAC	SL 220
CBR	600	RR ABS	PC40	09-	MSW 240	*	RAC		310	MST 425 RAC		220
FJS	600	Silver Wing	PF01	01-06	MST 373		RAC		256	MST 240	RAC	240
VT	600	C	PC21	88-93	MST 203				296			
VT	600	C	PC21	94-01	MST 203				296			
XL	600	R	PD03	83-87	MST 300				240			
XL	600	V Transalp	PD06	87-90	MST 202				276			
XL	600	V Transalp	PD06	91-96	MST 202				276	MST 240	RAC	240
XL	600	V Transalp	PD10	97-01	MST 201	*			256	MST 240	RAC	240
XR	600	R	PE04	87-90	MST 300				240			
XR	600	R	PE04	91-99	MST 300				240	MST 323		220
FX	650	Vigor	RD09	99-02	MST 205				276	MST 326		220
NT	650	Hawk GT	RC31	88-90	MST 207				318			
NTV	650	Revere	RC33	88-96	MST 207				318			
NTV	650	Deauville	RC47	98-05	MST 206	*	RAC		296	MST 202		276
NX	650	Dominator	RD02	88-89	MST 201				256	MST 326		220
NX	650	Dominator	RD02	90-92	MST 201				256	MST 245	RAC	220



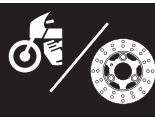
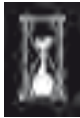

→ HONDA

NX	650	Dominator	RD02	93-97	MST 201			256	MST 326			220
NX	650	Dominator	RD08	98-03	MST 201			256	MST 326			220
SLR	650		RD09	97-98	MST 202			276	MST 326			220
XL	650	V Transalp	RD10	00-01	MST 201	*		256	MST 240	RAC		240
XL	650	V Transalp	RD11	02-07	MST 201	*		256	MST 240	RAC		240
XR	650	R	RE01	00-07	MST 300			240				
XR	650	L	RD06	93-99	MST 201			256	MST 245	RAC		220
XRV	650	Afrika Twin	RD03	88-90					MST 240	RAC		240
	670	Integra	NC700D	13-	MST 447 RAC			320	MST 446 RAC			240
DN-01	680		RC55	08-	MSW 272	*		296				
VF	700	S-C	RC21	84-85	MST 205			276				
NC	700	S, X, ABS	RC63	13-	MST 447 RAC			320	MST 446 RAC			240
NT	700	Deauville, ABS	RC52/RC59	06-	MST 206	*	RAC	296	MST 202			276
XLV	700	Transalp, ABS	RD13/RD15	08-	MST 201	*		256	MST 240	RAC		240
CB	750	Seven Fifty	RC42	92-03	MST 206	*	RAC	296	MST 240	RAC		240
CBX	750	F	RC17	84-87	MST 205	*		276	MST 202			276
VF	750	C	RC43	93-99	MST 207			318				
VFR	750	F	RC24	86-87	MST 205	*		276				
VFR	750	F	RC24	88-89	MST 206	*	RAC	296				
VFR	750	F	RC36	90-93	MST 206	*	RAC	296	MST 398			256
VFR	750	F	RC36	94-97	MSW 212	*	RAC	296	MST 398			256
VT	750	C Shadow	RC44	97-03	MST 206		RAC	296				
VT	750	C Shadow	RC50	04-	MST 206		RAC	296				
VT	750	C Shadow Spirit, Black Spirit	RC53	07-10	MST 206		RAC	296				
VT	750	D Black Widow	RC48	01-04	MST 206		RAC	296				
VT	750	S, SA		11-	MST 206		RAC	296				
XLV	750	R	RD01	84-88	MST 205			276				
XRV	750	Africa Twin	RD04	90-92	MST 204	*		276	MST 325			256
XRV	750	Africa Twin	RD07	93-03	MST 204	*		276	MST 325			256
PC	800	Pacific Coast	RC34	95-	MST 205	*		276				
VFR	800		RC46	98-11	MSW 236	*		296	MST 398			256
VFR	800	ABS	RC46	98-11	MSW 236	*		296	MST 426			256
VFR	800	Crossrunner, ABS	RC60	11-	MSW 236	*		296	MST 426			256
CB	900	Hornet	SC48	02-06	MSW 244	*		296	MST 240	RAC		240
CBR	900	RR	SC28	92-93	MSW 236	*		296	MST 245	RAC	SL	220
CBR	900	RR	SC28	94-95	MSW 212	*	RAC	296	MST 245	RAC	SL	220
CBR	900	RR	SC33	96-97	MSW 212	*	RAC	296	MST 245	RAC	SL	220
CBR	900	RR	SC33	98-99	MSW 227	*		310	MST 245	RAC	SL	220
CBR	900	RR	SC44	00-01	MSW 245	*		330	MST 245	RAC	SL	220
CBR	954	RR	SC50	02-03	MSW 245	*		330	MST 245	RAC	SL	220
CB	1000	R, ABS	SC60	08-	MSW 240	*	RAC	310	MST 390 RAC			256
CBF	1000	, ABS	SC58	06-	MSW 272	*		296	MST 338	RAC		240
CBR	1000	RR	SC57	04-05	MSW 240	*	RAC	310	MST 245	RAC	SL	220
CBR	1000	RR	SC57	06-07	MSW 254	*	RAC	320	MST 245	RAC	SL	220
CBR	1000	RR	SC59	08-	MSW 265 RAC	*		320	MST 245	RAC	SL	220
CBR	1000	RR ABS	SC59	09-	MSW 265 RAC	*		320	MST 427 RAC			220
CBR	1000	F	SC21	87-88	MST 206	*	RAC	296	MST 202			276
CBR	1000	F	SC24	89-92	MST 206	*	RAC	296				
CBR	1000	F	SC24	93-	MST 206	*	RAC	296				
VF	1000	F/II	SC15	84-87	MST 205	*		276				
VF	1000	R	SC16	84-87	MST 205	*		276				
VTR	1000	SP-1	SC45	00-01	MSW 254	*	RAC	320	MST 245	RAC	SL	220
VTR	1000	SP-2	SC45	02-	MSW 254	*	RAC	320	MST 245	RAC	SL	220
VTR	1000	Firestorm	SC36	97-08	MSW 212	*	RAC	296	MST 245	RAC	SL	220
XL	1000	Varadero	SD01	99	MSW 236	*		296	MST 325			256
XL	1000	Varadero	SD02	00-02	MSW 236	*		296	MST 325			256
XL	1000	Varadero, ABS	SD02	03-	MSW 236	*		296	MST 373	RAC		256
X-	1100	Even	SC42	00-	MSW 258 RAC	*		310	MST 373	RAC		256
CBR	1100	XX	SC35	99-08	MSW 258 RAC	*		310	MST 373	RAC		256
ST	1100	Pan European	SC26	90-02	MST 207	*		318				
ST	1100	Pan European ABS	SC26	92-95	MST 207	*		318				
ST	1100	Pan European ABS	SC26	96-02	MST 206	*	RAC	296				
VT	1100	Shadow	SC23	92-94	MST 207	*		318				
VT	1100	Shadow	SC32	95-02	MST 207	*		318	MST 202			276
VFR	1200	F, FA	SC63	10-	MSW 254	*	RAC	320	MST 448			276
VFR	1200	Crosstourer	SC70	12-	MST 449	*		310	MST 448			276
CB	1300	, ABS (Superfour)	SC54	05-	MSW 240	*	RAC	310	MST 373	RAC		256
CB	1300	S, SA	SC54	05-	MSW 240	*	RAC	310	MST 373	RAC		256
ST	1300	Pan European, ABS	SC51	02-	MSW 284	*		310	MST 428			316
VTX	1300	S	SC52	03-08	MST 206		RAC	296				
GL	1500	F6C Valkyrie	SC34	97-	MSW 236	*		296				
GL	1800		SC47	01-	MSW 236	*		296				
VTX	1800	C	SC46	02-08	MSW 244	*		296				

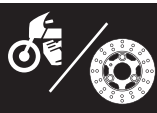

Husaberg

FE	400		Husaberg FE	00-	MST 265		RAC	EC	260	MST 266		RAC	EC	220
FE	400	E	Husaberg FE	01-	MST 265		RAC	EC	260	MST 266		RAC	EC	220
FS	400	C	Husaberg FE	01-	MST 265		RAC	EC	260	MST 266		RAC	EC	220
FS	400	E	Husaberg FE	01-	MST 265		RAC	EC	260	MST 266		RAC	EC	220
FC	501	CR	YU7FC...	00-	MST 265		RAC	EC	260	MST 266		RAC	EC	220
FE	501		Husaberg FE	00-	MST 265		RAC	EC	260	MST 266		RAC	EC	220
FE	501	E	Husaberg FE	01-	MST 265		RAC	EC	260	MST 266		RAC	EC	220
FC	600	CR	YU7FC...	00-	MST 265		RAC	EC	260	MST 266		RAC	EC	220
FE	600		Husaberg FE	00-	MST 265		RAC	EC	260	MST 266		RAC	EC	220
FE	600	Supermotard	Husaberg FE	00-	MSW 114				320	MST 266		RAC	EC	220
FS	650	C	Husaberg FE	01-	MSW 114				320					
FS	650	E	Husaberg FE	01-	MSW 114				320					

Husqvarna

WRS	50		WRS	00-	MST 236		RAC		190					
CR	125		ZCG...	92-94	MST 319				260	MST 351				220
CR	125		ZCG...	95-99	MST 319				260	MST 351				220
CR	125		ZCG...	00-05	MST 320			EC	260	MST 353				220
CR	125			06-10	MST 320			EC	260	MST 399				240
CR	125			11-	MST 320			EC	260	MST 440 EC				240
SM	125	S	ZCG...	01-10	MST 320			EC	260	MST 353				220
TE	125			11-	MST 320			EC	260	MST 351				220
WR	125		ZCG...	92-94	MST 319				260	MST 351				220
WR	125		ZCG...	95-99	MST 319				260	MST 351				220
WR	125	Hersteller: MV Agusta	2H	00-05	MST 320			EC	260	MST 353				220
WR	125			06-10	MST 320			EC	260	MST 399				240
WR	125			11-	MST 320			EC	260	MST 440 EC				240
WRE	125			02-10	MST 320			EC	260	MST 353				220
WRX	125			07-	MST 320			EC	260	MST 353				220
CR	250		ZCG...	92-99	MST 319				260	MST 351				220
CR	250		ZCG...	00-05	MST 320			EC	260	MST 353				220
TC/TXC	250		ZCG...	03-05	MST 320			EC	260	MST 353				220
TC/TXC	250			06-10	MST 320			EC	260	MST 399				240
TC/TXC	250			11-	MST 320			EC	260	MST 440 EC				240
TE	250	Hersteller: MV Agusta	H8	03-05	MST 320			EC	260	MST 353				220
TE	250			06-10	MST 320			EC	260	MST 399				240
TE	250			11-	MST 320			EC	260	MST 440 EC				240
WR	250		ZCG...	92-99	MST 319				260	MST 351				220
WR	250	Hersteller: MV Agusta	3H	00-10	MST 320			EC	260	MST 353				220
WR	300			09-10	MST 320			EC	260	MST 353				220
TE	310			09-10	MST 320			EC	260	MST 399				240
TE	310			11-	MST 320			EC	260	MST 440 EC				240
TE	350		ZCG...	92-98	MST 319				260	MST 351				220
CR	360		ZCG...	92-94	MST 319				260	MST 351				220
WR	360		ZCG...	92-99	MST 319				260	MST 351				220
WR	360	Hersteller: MV Agusta	3H	00-02	MST 320			EC	260	MST 353				220
TE	400	Hersteller: MV Agusta	H8	01-02	MST 320			EC	260	MST 353				220
TE	410		ZCG...	95-99	MST 319				260	MST 351				220
TE	410		ZCG...	00	MST 320			EC	260	MST 353				220
TE	449			11-	MST 320			EC	260	MST 440 EC				240
TC/TE	450		ZCG...	03-04	MST 320			EC	260	MST 353				220
TE	450	Hersteller: MV Agusta	H8	05-10	MST 320			EC	260	MST 399				240
TC/TXC	450			05-10	MST 320			EC	260	MST 399				240
TE/TXC	510			04-05	MST 320			EC	260	MST 353				220
TE/TXC	510			06-10	MST 320			EC	260	MST 399				240
TE	510			11-	MST 320			EC	260	MST 440 EC				240
TC	510			04-05	MST 320			EC	260	MST 353				220
TC	510			06-10	MST 320			EC	260	MST 399				240
TE	570	Hersteller: MV Agusta	H8	01-03	MST 320			EC	260	MST 353				220
TC	610		ZCG...	92-99	MST 319				260	MST 351				220
TC	610		ZCG...	00	MST 320			EC	260	MST 353				220
TE	610	, Electric	ZCG...	92-99	MST 319				260	MST 351				220
TE	610	Electric	H7	98-01	MST 319				260	MST 351				220
TE	610	E, IE		02-	MST 320			EC	260	MST 353				220
TE	610		ZCG...	00	MST 320			EC	260	MST 353				220
TE	630			10-	MST 320			EC	260					
	900	Nuda, R		12-						MST 372		RAC		265

Hyosung

CAB	50		SB	95-	MST 250				155					
GV	650			04-	MSW 224		RAC		298					
GV	700			06-09	MSW 224		RAC		298					

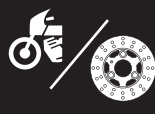

Italjet

50			92-	MST 250					155				
50	Bazooka 2		92-97	MST 250					155				
50			94-	MST 250					155				

Kawasaki

KX	65		KX65	01-12	MST 443 EC								MST 443 EC				
KX	80		KX80N	88-00									MST 332				184
KX	85		KX85	01-12	MST 441 EC								MST 442 EC				
KX	100		KX100N	88-00									MST 332				184
KX	125		KX125K	89-02	MST 306					250			MST 333				220
KX	125		KX125M	03-05	MST 307			RAC		250			MST 339	RAC	EC		240
KX	125		KX125	06-08	MST 308 RAC			EC		250			MST 339	RAC	EC		240
KDX	200		KDX200	86-03	MST 307			RAC		250			MST 335				220
KDX	220		KDX225	94-03	MST 307			RAC		250			MST 335				220
	250	R Ninja	EX250K	08-12	MST 421 RAC					290			MST 422 RAC				220
KDX	250		KDX250	91-98	MST 306					250			MST 335				220
KLX	250	R	LX250E	93-98	MST 306					250			MST 336				230
KLX	250	SE	LX250B	93-98	MST 307			RAC		250			MST 336				230
KLX	250	SR	LX250B	93-98	MST 307			RAC		250			MST 336				230
KLX	250			09-	MST 307			RAC		250							
KX	250		KX250M	89-02	MST 306					250			MST 333				220
KX	250		KX250M	03-05	MST 307			RAC		250			MST 339	RAC	EC		240
KX	250		KX250	06-	MST 308 RAC			EC		250			MST 339	RAC	EC		240
KX-F	250		KXF250	04-05	MST 307			RAC		250			MST 339	RAC	EC		240
KX-F	250		KXF250	06-12	MST 308 RAC			EC		250			MST 339	RAC	EC		240
ZZR	250		EX250H	92-	MSW 215	*		RAC		300							
	300	R Ninja ABS	EX300A	13-	MST 421 RAC					290			MST 422 RAC				220
KLX	300		LX300B	96-07	MST 306					250			MST 333				220
KFX	400		AK47B	03-	MST 402					160			MST 323				220
KLX	400	R	LX400	03-06	MST 311			RAC		250			MST 341	RAC			220
ZRX	400		ZR400E	94-01	MSW 215			RAC		300							
ZXR	400		ZX400L	89-90	MSW 215	*		RAC		300							
ZXR	400		ZX400L/M	91-03	MSW 214	*		RAC		310							
ZZR	400		ZX400K/N	90-99	MSW 215			RAC		300							
KFX	450		SF450B	07-	MST 408					163			MST 413				
KLX	450	R	LX450	07-12	MST 308 RAC			EC		250			MST 339	RAC	EC		240
KX	450	F	KX450	05-12	MST 308 RAC			EC		250			MST 339	RAC	EC		240
EN	500		EN500B/C	94-04	MST 210					300							
KX	500		KX500E	90-03	MST 306					250			MST 333				220
ZR	550	Zephyr	ZR550B	91-99	MSW 215	*		RAC		300							
ZL	600	Eliminator	ZL600B	95-97	MSW 215	*		RAC		300							
ZX-6R	600	Ninja	ZX600F	95-97	MSW 215	*		RAC		300							
ZX-6R	600	Ninja	ZX600G	98-99	MSW 228	*				296			MST 366	RAC	SL		220
ZX-6R	600	Ninja	ZX600J	00-01	MSW 215	*		RAC		300			MST 366	RAC	SL		220
ZX-6RR	600	Ninja	ZX600K	03-04	MSW 238	*				280			MST 366	RAC	SL		220
ZX-6RR	600	Ninja	ZX600N	05-06	MSW 257 RAC	*				300			MST 366	RAC	SL		220
ZX-6R	600	Ninja	ZX600P	07-08	MSW 257 RAC	*				300			MST 366	RAC	SL		220
ZX-6R	600	Ninja	ZX600R	09-	MSW 257 RAC	*				300			MST 366	RAC	SL		220
ZZR	600		ZX600D	90-92	MSW 215	*		RAC		300							
ZZR	600		ZX600E	93-05	MSW 215	*		RAC		300							
ZX-6R	636	Ninja	ZX600A	02	MSW 215	*		RAC		300			MST 366	RAC			220
ZX-6R	636	Ninja	ZX600B	03-04	MSW 238	*				280			MST 366	RAC			220
ZX-6R	636	Ninja	ZX600C	05-06	MSW 257 RAC	*				300			MST 366	RAC			220
ZX-6R	636	Ninja ABS	ZX600R	13-	MSW 264 RAC	*				310			MST 445 RAC				220
ER-6	650	F, ABS ←	EX650A/C/E	06-	MSW 274 RAC					300			MST 397 RAC				220
ER-6	650	F, ABS →	EX650A/C/E	06-	MSW 257 RAC												
ER-6	650	N	ER650A/C/E	06-	MSW 257 RAC	*				300			MST 366	RAC			220
ER-6	650	N, ABS ←	ER650A/C/E	06-	MSW 274 RAC					300			MST 397 RAC				220
ER-6	650	N, ABS →	ER650A/C/E	06-	MSW 257 RAC												
KLE	650	Versys	LE650A/C/D	07-	MSW 257 RAC	*				300			MST 366	RAC			220
KLE	650	Versys ABS ←	LE650A/C/D	07-	MSW 274 RAC					300			MST 397 RAC				220
KLE	650	Versys ABS →	LE650A/C/D	07-	MSW 257 RAC												
KLX	650	R	LX650C	93-03						250			MST 336				230
KVF	650		KVF650	02-	MST 415					200							
KFX	700		SV700A	07-	MST 408					163							
KVF	700	Bruteforce	KVF700	04-06	MST 415					200							
KVF	750	Bruteforce	KVF750	05-	MST 415					200							
Z	750		ZR750J/K	04-06	MSW 215	*		RAC		300			MST 366	RAC			220
Z	750	,ABS	ZR750L/N	07-12	MSW 257 RAC	*				300			MST 375 RAC				250
ZR	750	Zephyr	ZR750C	91-99	MSW 215	*		RAC		300							





→ **KAWASAKI**

ZR-7	750		ZR750F	99-04	MSW 215	*	RAC	300						
ZX-7R	750	Ninja	ZX750N	96-03	MSW 216	*	RAC	320	MST 367				230	
ZX-7RR	750	Ninja	ZX750N	96-99	MSW 216	*	RAC	320	MST 367				230	
ZXR	750	Stinger	ZX750H	89-90	MSW 216	*	RAC	320	MST 367				230	
ZXR	750	R	ZX750H	89-90	MSW 214	*	RAC	310	MST 367				230	
ZXR	750	R	ZX750K	91-92	MSW 216	*	RAC	320	MST 367				230	
ZXR	750	R	ZX750M	93-95	MSW 216	*	RAC	320	MST 367				230	
ZXR	750		ZX750J	91-92	MSW 216	*	RAC	320	MST 367				230	
ZXR	750		ZX750L	93-95	MSW 216	*	RAC	320	MST 367				230	
VN	800		VN800A (A)	95-	MST 210			300						
VN	800	Classic	VN800A (B)	96-06	MST 210			300						
VN	800	Drifter	VN800C	99-04	MST 210			300						
Z	800	,ABS	ZR800A/C	13-	MSW 264 RAC	*		310	MST 375 RAC				250	
Z	800	e version, ABS	ZR800A/C	13-	MSW 264 RAC	*		310	MST 375 RAC				250	
GPZ	900	R	ZX900A(-A11)	90-98	MSW 215		RAC	300						
ZX-9R	900	Ninja	ZX900B	94-97	MSW 216	*	RAC	320	MST 367				230	
ZX-9R	900	Ninja	ZX900C	98-99	MSW 228	*		296	MST 366	RAC	SL		220	
ZX-9R	900	Ninja	ZX900E	00-01	MSW 214	*	RAC	310	MST 366	RAC	SL		220	
ZX-9R	900	Ninja	ZX900F	02-03	MSW 216	*	RAC	320	MST 366	RAC	SL		220	
GTR	1000		ZGT00A	94-03	MSW 215	*	RAC	300						
KLE	1000	Versys	LZT00A	12-	MSW 257 RAC	*		300	MST 375 RAC				250	
KLV	1000		LV1000A	04-	MSW 250	*	RAC	310	MST 368				260	
Z	1000		ZRT00A	03-06	MSW 215	*	RAC	300	MST 366	RAC			220	
Z	1000		ZRT00B/C	07-09	MSW 257 RAC	*		300	MST 375 RAC				250	
Z	1000	,ABS	ZRT00D	10-	MSW 257 RAC	*		300	MST 375 RAC				250	
Z	1000	SX, ABS	ZXT00G	11-	MSW 257 RAC	*		300	MST 375 RAC				25	
OZX-10R	1000		ZX100C/D	04-07	MSW 257 RAC	*		300	MST 366	RAC	SL		220	
ZX-10R	1000		ZX100E	08-10	MSW 264 RAC	*		310	MST 366	RAC	SL		220	
ZX-10R	1000	,ABS	ZX100F	11-	MSW 264 RAC	*		310	MST 445 RAC				220	
GPZ	1100		ZXT10E	95-99	MSW 215	*	RAC	300						
ZR	1100	Zephyr	ZRT10A/B	93-97	MSW 214	*	RAC	310						
ZRX	1100		ZRT10C	97-00	MSW 214	*	RAC	310						
ZZR	1100	C	ZXT10C	90-92	MSW 214	*	RAC	310						
ZZR	1100	D	ZXT10D	93-01	MSW 216	*	RAC	320						
ZRX	1200	S	ZRT20A/B	01-	MSW 214	*	RAC	310						
ZX-12R	1200		ZXT20A	00-03	MSW 216	*	RAC	320						
ZX-12R	1200		ZXT20C	04-	MSW 215	*	RAC	300						
ZZR	1200		ZXT20C	02-04	MSW 216	*	RAC	320						
GTR	1400	,ABS	ZG1400A/C	07-	MSW 264 RAC	*		310					250	
ZZR	1400	,ABS	ZXT40A/C/E	06-	MSW 264 RAC	*		310	MST 375 RAC				250	
VN	1500	Mean Streak	VNT50P	02-04	MSW 216		RAC	320						
VN	1500	Sumo	VNT50A	94-96	MST 210			300						
VN	1500	Classic	VNT50D	96-99	MST 210			300						
VN	1600	Mean Streak	VNT60B	04-08	MSW 216		RAC	320						

KTM

	50	Kross	KTM GO 50	96-	MST 236		RAC	190						
SX	85		SX85	04-10	MST 309 RAC		EC	220	MST 314 RAC		EC		200	
SX	85			11	MST 309 RAC		EC	220	MST 463 EC				210	
SX	85	„(14“ „)“		12-	MST 309 RAC		EC	220	MST 463 EC				210	
	125	Sting	KTM 125	97-99	MSW 314			320	MST 266	RAC	EC		220	
EXC	125	Enduro	KTM-2T-EXC	98-12	MST 265		RAC	EC	260	MST 266	RAC	EC	220	
MX	125			94-95	MST 265		RAC	EC	260	MST 266	RAC	EC	220	
SX	125		VBKMXH...	96-	MST 265		RAC	EC	260	MST 266	RAC	EC	220	
	125			89-90					MST 340				220	
EXC	200	Enduro	KTM-2T-EXC	98-12	MST 265		RAC	EC	260	MST 266	RAC	EC	220	
SX	200		VBKMXK...	03-	MST 265		RAC	EC	260	MST 266	RAC	EC	220	
EXC	250	,EXC-F	KTM-2T-EXC	03-12	MST 265		RAC	EC	260	MST 266	RAC	EC	220	
GS	250			94-97	MST 265		RAC	EC	260	MST 266	RAC	EC	220	
SX	250		VBKMXN...	03-12	MST 265		RAC	EC	260	MST 266	RAC	EC	220	
SX	250		VBKMXN...	94-05	MST 265		RAC	EC	260	MST 266	RAC	EC	220	
SX-F	250		SXF250	06-12	MST 265		RAC	EC	260	MST 266	RAC	EC	220	
	250			89-90					MST 340				220	
EXC	300		KTM-2T-EXC	98-12	MST 265		RAC	EC	260	MST 266	RAC	EC	220	
GS	300			93-	MST 265		RAC	EC	260	MST 266	RAC	EC	220	
SX	300		SX300	94-02	MST 265		RAC	EC	260	MST 266	RAC	EC	220	
GS	350	4Takt		93-97	MST 265		RAC	EC	260	MST 266	RAC	EC	220	
	350			89-91					MST 340				220	
SX-F	350			10-12	MST 265		RAC	EC	260	MST 266	RAC	EC	220	
EXC	380		EXC380	98-02	MST 265		RAC	EC	260	MST 266	RAC	EC	220	



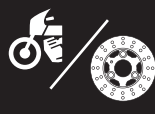

→ KTM

SX	380		SX380	96-02	MST 265		RAC	EC	260	MST 266	RAC	EC	220
EXC	400	, Racing	KTM-4T-EXC	94-	MST 265		RAC	EC	260	MST 266	RAC	EC	220
LC4	400	EGS 4-T	KTM-4T-EGS	96-02	MST 310				300				
SX	400		SX400	00-07	MST 265		RAC	EC	260	MST 266	RAC	EC	220
EXC	450	, Racing	KTM-4T-EXC	03-12	MST 265		RAC	EC	260	MST 266	RAC	EC	220
	450	SMR		05-						MST 266	RAC	EC	220
SX-F	450		VBKMXN...	03-12	MST 265		RAC	EC	260	MST 266	RAC	EC	220
XC	450			08-	MST 384				180	MST 385			200
MX	500		MX500	94-99	MST 265		RAC	EC	260	MST 266	RAC	EC	220
SX	500		SX500	94-99	MST 265		RAC	EC	260	MST 266	RAC	EC	220
	500			89-91						MST 340			220
SX-F	505		SXF505	07-	MST 265		RAC	EC	260				
XC	505			08-	MST 384				180	MST 385			200
EXC	520		KTM-4T-EXC	00-02	MST 265		RAC	EC	260	MST 266	RAC	EC	220
SX	520		VBKMXM...	00-02	MST 265		RAC	EC	260	MST 266	RAC	EC	220
	525	SMR		05-07						MST 266	RAC	EC	220
EXC	525		KTM-4T-EXC	03-07	MST 265		RAC	EC	260	MST 266	RAC	EC	220
SX	525		VBKMXM...	03-07	MST 265		RAC	EC	260	MST 266	RAC	EC	220
XC	525	Racing		06-	MST 265		RAC	EC	260				
EXC	530			08-12	MST 265		RAC	EC	260	MST 266	RAC	EC	220
LC4	540			99-00	MST 265		RAC	EC	260	MST 266	RAC	EC	220
	560	SMR		05-12						MST 266	RAC	EC	220
LC4	600	4Takt		89-90						MST 340			220
LC4	600	4Takt		94-00	MST 265		RAC	EC	260	MST 266	RAC	EC	220
LC4	620	EGS	KTM-4T-EGS	96-02	MST 310				300				
	620	Duke		95-98	MSW 314				320	MST 266	RAC	EC	220
	620	Adventure		96-99	MST 310				300	MST 266	RAC	EC	220
LC4	625	SXC Supercomp	KTM-4T-EGS	02-07	MST 265		RAC	EC	260	MST 266	RAC	EC	220
	640	Duke 2	KTM DKII	99-02	MSW 314				320	MST 266	RAC	EC	220
LC4	640		KTM-4T-EGS	01-03	MST 310				300				
LC4	640	Supermoto	KTM-4T-EGS	03-	MSW 114		RAC		320	MST 266	RAC	EC	220
LC4	640	Adventure	KTM-4T-EGS	00	MST 310				300	MST 266	RAC	EC	220
LC4	640	Adventure	KTM-4T-EGS	01-02	MSW 114				320	MST 266	RAC	EC	220
LC4	640	Enduro	KTM-4T-EGS	06-07	MST 310				300	MST 266	RAC	EC	220
LC4	660	SMC Supermoto	4T-SC	03-07	MSW 114		RAC		320	MST 266	RAC	EC	220
	660	Rally	KTM Rally	99-03	MST 310				300	MST 266	RAC	EC	220
	690	Duke, Duke R, ABS	KTM Duke	08-	MSW 211		RAC		320	MST 378 RAC			240
	690	Enduro, Enduro R		08-	MSW 277 RAC				300	MST 439			240
	690	SM, SMC, SM-LE	KTM LC-4	07-	MSW 114		RAC		320	MST 439			240
	690	SM Prestige	KTM LC-4	07	MSW 211		RAC		320	MST 378 RAC			240
	690	SMR	KTM LC-4	08-09	MSW 211		RAC		320	MST 378 RAC			240
	950	Super Enduro	KTM LC-8	07-09	MSW 277 RAC				300	MST 439			240
	950	SMR, SMT	KTM LC-8	07-10	MSW 282 RAC				305	MST 378 RAC			240
	990	Adventure S	KTM LC-8	06-08	MSW 277 RAC				300	MST 439			240
	990	Adventure, R, ABS	KTM LC-8	09-	MSW 277 RAC				300	MST 438			240
	990	SMR, ABS	KTM LC-8	09-12	MSW 282 RAC	*			305	MST 378 RAC			240
	990	SMT, ABS	KTM LC-8	11-	MSW 282 RAC	*			305	MST 378 RAC			240
	990	Superduke, R	KTM LC-8	05-	MSW 211	*	RAC		320	MST 378 RAC			240
RC-8	1200		KTM RC-8	08-	MSW 211	*	RAC		320				

Kymco

	50	Agility		05-08	MST 256				180				
	50	„Agility 10“ „	CV50QTS	06-	MST 256				180				
	50	„Agility 12“ „	CK50QTS	06-	MST 256				180				
	50	Cobra Cross/Racer		00-06	MST 256				180	MST 256			180
	50	Heroism	KCZ	95-	MST 241				162				
S	50	People 2 T	B9	07-	MST 260		RAC		200				
KB	50		KB	95-00	MST 241				162				
	50	K 12, Scout	K12	95-	MST 241				162				
	50	Calypto	KCZ	97-	MST 241				162				
	50	Dink	KCZ	98-06	MST 256				180				
	50	Topboy	SF10	98-05	MST 256				180				
CX	50	Super	KCP	95-	MST 241				162				
	50	Mxer	L2	00-	MST 256				180	MST 256			180
	50	Super 9, LC	S1	00-06	MST 256				180	MST 256			180
	50	Sniper		93-	MST 241				162				
	50	Sniper DD		94-	MST 241				162				
	50	Spacer	SH	98-	MST 256				180	MST 256			180
	50	Super Fever, Scout	KCA/SC10	99-06	MST 256				180	MST 256			180
	50	Vitality Cross, Sport	U3	05-09	MST 256				180	MST 256			180





→ KYMCO

	50	Yager	SH10	98-	MST 256				180	MST 256			180
	50	Yup	S6	02-09	MST 256				180	MST 256			180
	90	Maxxer		05-06	MST 256				180				
KB	100	Manboy	KB	97-00	MST 241					162			
	125	„Agility 12“ „	CK125T-6	06-10	MST 256				180	MST 256			180
	125	Calypto	KAF	97-	MST 241				162				
	125	Dink, Dink LX	SH30	97-04	MST 256				180	MST 256			180
	125	Grand Dink	S4	01-02	MST 256				180	MST 256			180
	125	Heroism	KAF	95-97	MST 241				162				
	125	Movie	S5	01-	MST 256				180	MST 256			180
	125	Mxer	L1	02-	MST 256				180	MST 256			180
	125	Spacer	SH25	97-	MST 256				180	MST 256			180
	125	Yager	SH	00-	MST 256				180	MST 256			180
	150	Heroism	KBF	95-97	MST 241				162				
	150	Dink	S3	97-	MST 256				180	MST 256			180
	150	Grand Dink	S4	01-02	MST 256				180	MST 256			180
	150	Mxer	L1	02-	MST 256				180	MST 256			180
	150	Spacer		97-	MST 256				180	MST 256			180

Laverda

	650	Sport	ZLVSTA...	95-01	MSW 211	*	RAC		320	MST 247	RAC		245
	650	Ghost	ZLVSPA...	96-97	MSW 211	*	RAC		320	MST 247	RAC		245
	750	S Formula	ZLVSTA...	98-01	MSW 211	*	RAC		320	MST 247	RAC		245
	750	Strike	Strike	98-01	MSW 211	*	RAC		320	MST 247	RAC		245
	1000	SFC		03-	MSW 211	*	RAC		320				

Malaguti

	50	Ciak	52	00-03	MST 252		RAC		190	MST 252	RAC		190
	50	F-10 Jetline	ZJM39D	92-	MST 258				155				
	50	F-12	ZJM40	94-	MST 252		RAC		190	MST 252	RAC		190
	50	F-12 Phantom	ZJM41D	94-08	MST 252		RAC		190	MST 252	RAC		190
	50	Centro	ZJM42D	94-00	MST 260		RAC		200				
	50	F-15 Firefox	44	96-97	MST 252		RAC		190				
	50	F-15 Firefox LC	44	98-08	MST 252		RAC		190	MST 252	RAC		190
	50	Yesterday	45	98-	MST 258				155				
CR-1	50	Crosser	ZJM43	95-01	MST 252		RAC		190	MST 252	RAC		190
DVD	50	Malbo Line		10-	MST 250				155				
	100	Ciak		00-03	MST 252		RAC		190	MST 252	RAC		190
	100	F-12 Phantom	46	99-						MST 252	RAC		190

MBK

CR	50	Target	4BX	92-94	MST 250				155				
CS	50	Mach G	SA22	02-10	MST 236		RAC		190				
CV	50	Evolis	4FW	92-97	MST 250				155				
CW	50	Booster Spirit	4BX	95-98	MST 250				155				
CW	50	Booster Spirit	SA05	99	MST 257				180				
CW	50	Booster Naked	SA05	06-	MST 257				180				
CW	50	Booster Next G.	4BXM	95-00	MST 257				180				
CW	50	RS Booster Next G	4BX	01-06	MST 243		RAC		190				
CW	50	Booster Track	4VA	96-	MST 257				180				
CW	50	Booster Rocket	4VA	97-	MST 257				180				
CW	50	Booster Road	4BX	93-95	MST 250				155				
CW	50	Power Rocket	SA05	06-	MST 257				180				
CY	50	Forte	3UG	94-97	MST 250				155				
EW	50	Stunt	SA09	00-06	MST 243		RAC		190				
EW	50	Stunt Naked	SA09	05-	MST 243		RAC		190				
YM	50	Fizz	4RC	94-97	MST 250				155				
YN	50	Ovetto	5AD	97-10	MST 236		RAC		190				
	50	Nitro	5BR	97-01	MST 243		RAC		190	MST 243	RAC		190
YQ	50	Nitro, Nitro Naked	5BR/SA14	97-10	MST 243		RAC		190	MST 243	RAC		190
CV	80	Evolis	4FW	97	MST 250				155				
YN	100	Ovetto	SB04	00-03	MST 236		RAC		190				
YQ	100	Nitro	SB05	99-03	MST 243		RAC		190				
XN	125	Doo Do	SE04	00-05	MST 259				220				
XQ	125	Thunder	SE05	01-	MST 370				245	MST 259			220
YP	125	Skycruiser		06-10	MSW 269				267				
YP	125	Skyliner	5DS	96-00	MST 259				220				
QP	150	Thunder	SG06	01-	MST 370				245	MST 259			220
XQ	150	Skyliner		98-00	MST 259				220				
YP	180	Skyliner		03-	MST 259				220				



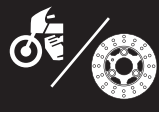

→ MBK

YP	250	Skyliner	5GM	96-00	MST 247					245
YP	400	Skyliner		04	MSW 269					267

Moto Guzzi

V7	750	Classic, Cafe Classic	LW	07-12	MSW 211		RAC			320
V7	750	Racer, Special, Stone		10-	MSW 211		RAC			320
	750	Nevada	LM	05-	MSW 211	*	RAC			320
	850	Griso	LS	07-	MSW 211		RAC			320
	850	Norge		07	MSW 211		RAC			
	936	Bellagio		08-	MSW 211	*	RAC			320
	940	Custome	LY	07-	MSW 211	*	RAC			320
	1000	G5	VG	95-	MSW 211		RAC			320
RS	1000	Daytona I.E.	KA	92-94	MSW 221	*	RAC			300
RS	1000	Daytona	KL	95-	MSW 211	*	RAC			320
V 10	1000	Centaurio, SP	KK	97-99	MSW 211	*	RAC			320
	1000	Convert		96-	MSW 211		RAC			320
	1100	Breva	LP	05-	MSW 211		RAC			320
	1100	Griso	LS	07-	MSW 211	*	RAC			320
	1100	Sport	KR	95-97	MSW 211		RAC			320
EV	1100	California SP	KD	97-	MSW 211	*	RAC			320
EV	1100	California	KD	98-	MSW 211	*	RAC			320
EV	1100	California Jackal	KD	94-01	MSW 211	*	RAC			320
EV	1100	Touring		03-05	MSW 211		RAC			320
	1100	California Aquila Nera		09-11	MSW 211		RAC			320
	1100	California Classic Touring		06-08	MSW 211		RAC			320
	1100	California Stone		01-05	MSW 211		RAC			320
	1100	California Vintage		06-	MSW 211	*	RAC			320
	1100	California 90		12-	MSW 211	*	RAC			320
V 11	1100	Ballabio		03-05	MSW 211	*	RAC			320
V 11	1100	Le Mans, Scura, Naked	KR	00-05	MSW 211	*	RAC			320
V 11	1100	Sport	KF	99-	MSW 211	*	RAC			320
	1200	Breva ohne ABS/no ABS	LP	08-	MSW 211	*	RAC			320
	1200	Griso 8V	LS	07-	MSW 211	*	RAC			320
GT	1200	Norge ohne ABS/no ABS	LS	06-	MSW 211	*	RAC			320
	1200	Sport 4V	LP	06-	MSW 211	*	RAC			320
	1200	Stelvio ohne ABS/no ABS	LZ	08-	MSW 211	*	RAC			320

MUZ

FB	50	Moskito	FB50	97-03	MST 250					155
JP	50	SX	JP	00-03	MST 250					155
	650	„Baghira 21“ „Speichenrad“		96-05	MST 233					280

Peugeot

	50	Buxy	FE053DE	94-	MST 252		RAC			190
	50	Elyseo	G1A	98-02	MST 252		RAC			190
	50	Elyseo	G1A	03	MST 261		RAC		MST 261	RAC 180
	50	Elystar Advantage		02-07	MST 261		RAC		MST 261	RAC 180
	50	Looxor TSDi	B1	06-	MST 252		RAC		MST 252	RAC 190
	50	Ludix Elegance	L1	04-	MST 252		RAC		MST 252	RAC 190
	50	„Ludix Pro 14“ „“		11-	MST 252		RAC		MST 252	RAC 190
	50	TRK2, WRC	S1	99-08	MST 252		RAC			190
	50	„TRK 10“ „12“ „“		09-	MST 252		RAC			190
	50	Trekker	S1ADE	97-00	MST 252		RAC			190
	50	Squab	S1ADE	94-01	MST 252		RAC			190
	50	Speedake	FE053DE	95-01	MST 252		RAC			190
	50	Speedfight SC	S1BDE	97-08	MST 261		RAC		MST 261	RAC 180
	50	V-Clic		08-	MST 250					155
	50	Vivacity	S1C	92-11	MST 252		RAC			190
	50	Zenith Luxe	FE052ADE	96-	MST 258					155
SV	50		F052DE	92-	MST 252		RAC			190
SV	50	Geo	F082	92-	MST 252		RAC			190
	100	Elyseo	G12A	03	MST 261		RAC		MST 261	RAC 180
	100	Looxor		01-04	MST 252		RAC		MST 252	RAC 190
	100	Speedfight SC	S1BDE	97-07	MST 261		RAC		MST 261	RAC 180
	100	Trekker	S2A	98	MST 252		RAC			190
	100	Vivacity	S2A	99-	MST 252		RAC		MST 252	RAC 190
SV	125	Geo	F121	91-	MST 252		RAC			190
	125	Looxor	P2	03-04	MST 252		RAC		MST 252	RAC 190
	125	Ludix Ambition	L1A	04-	MST 252		RAC		MST 252	RAC 190
	150	Looxor	P2A	03-04	MST 252		RAC		MST 252	RAC 190
SV	250		N2	01-02	MST 453				240	MST 245 220



PGO

	50	Big Max	PM	95-	MST 250			155			
	50	Mega fifty		99-	MST 250			155			
	50	Rodoshow	PE	01-	MST 250			155			
	50	T-Rex	CP	99-	MST 243		RAC	190	MST 243	RAC	190
	50	Tornado	PT	97-	MST 250			155			
PMS	50		PM	99	MST 243		RAC	190			
PMX	50		PM	99-	MST 243			155	MST 243	RAC	190
	80	Big Max	PS	95-	MST 250			155			
	125	BuBu		03-	MST 243		RAC	190			
	125	Ligero		06-	MST 243		RAC	190			
	125	Tornado		97-	MST 250			155			
	125	T-Rex	CP0	99-	MST 243		RAC	190	MST 243	RAC	190
	150	T-Rex	CP2	99-	MST 243		RAC	190			

Piaggio

	50	Diesis	C34	01-05	MST 236		RAC	190			
	50	Fly	C44	05-	MST 260		RAC	200			
	50	Free	FCS	97-	MST 260		RAC	200			
	50	Liberty	C15	97-08	MST 396			220			
	50	Stalker	C13	97-	MST 236		RAC	190			
	50	Quartz	NSP	91-95	MST 260		RAC	200			
	50	Zip Fast Rider	SSL	93-99	MST 250			155			
	50	Zip Base	SSL	95-96	MST 250			155			
	50	Zip S.P., LC	C11	96-	MST 260		RAC	200			
	50	Zip Catalyzer	C25	00	MST 250			155			
	50	Zip 2T, 4T	C25	00-	MST 255			175			
	50	Typhoon	TEC	94-97	MST 236		RAC	190			
	50	Typhoon X, XR	TEC	98-00	MST 236		RAC	190			
	50	Typhoon	C29	01-09	MST 236		RAC	190			
ET2	50	Vespa	C12	97-05	MST 260		RAC	200			
ET2	50	Vespa	C16	97-05	MST 260		RAC	200			
ET4	50	Vespa		00-04	MST 260		RAC	200			
NRG	50	Scooter	SAL	94-98	MST 236		RAC	190			
NRG	50	Extreme	C21, C22	99-01	MST 254			220	MST 255		174
NRG	50	RST	C21	96-98	MST 236		RAC	190	MST 255		174
NRG	50	MC2 SP	C04	99-	MST 254			220	MST 255		174
NRG	50	MC3 DD/DT	C30	01-05	MST 254			220	MST 255		174
NRG	50	Power DD/DT	C45	05-	MST 396			220	MST 255		174
NRG	50	Power Pure Jet	C32	04-09	MST 396			220	MST 255		174
NRG	50	Silver Bullet		10-	MST 396			220	MST 255		174
NTT	50		SAL	94-96	MST 236		RAC	190			
LX	50		Vespa	05-	MST 260		RAC	200			
LXV	50		Vespa	07-09	MST 396			220			
RST	50	Sfera	NSL/C01	95-99	MST 260		RAC	200			
S	50	, Sport	Vespa	07-	MST 260		RAC	200			
	80	Skipper		94-	MST 260		RAC	200			
	80	Typhoon	TEC80	96-	MST 254			220			
	100	Diesis		01-03	MST 236		RAC	200			
	100	Fly 4T		07-	MST 260		RAC	200	MST 260	RAC	200
	100	Free		02-	MST 260		RAC	200			
	100	Zip		07-	MST 260		RAC	200	MST 260	RAC	200
	125	Beverley	M28	02-09	MST 398			260	MST 398		260
	125	Carnaby	M60	07-09	MST 398			260	MST 398		260
	125	Free		05-	MST 260		RAC	200			
	125	Fly	M42	05-	MST 260		RAC	200			
	125	Typhoon	M02	95-03	MST 236		RAC	190			
	125	Hexagon	M05	98-	MST 260		RAC	200			
	125	Liberty	M22	98-08	MST 396			220			
	125	MP3, ie	M47	06-11	MST 394			240	MST 395		240
	125	ie MP3 YOUrban		11-	MST 394			240	MST 395		240
	125	MP3 Hybrid		09-	MST 394			240	MST 395		240
	125	Skipper	M12	93-97	MST 260		RAC	200			
	125	Skipper	M12	98-	MST 254			220			
	125	XEvo		08-	MST 393			260	MST 395		240
	125	Zip	M25	00-	MST 260		RAC	200			
ET4	125	Vespa	M04	97-05	MST 260		RAC	200			
GT	125	Granturismo	Vespa/M31	04-06	MST 396			220	MST 396		220
GTS	125	, Super/Sport	Vespa/M31	07-	MST 396			220	MST 396		220
GTV	125		Vespa/M31	07-09	MST 396			220	MST 396		220
GTX	125	Super Hexagon	M20	00	MST 260		RAC	200	MST 260	RAC	200
GTX	125	Super Hexagon		01-03	MST 395			240			



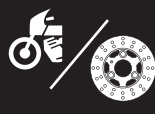

→ PIAGGIO

LX	125		Vespa	05-	MST 260		RAC	200				
PX	125	E Lusso	Vespa/M09	98-	MST 260		RAC	200				
RST	125	Sfera	M01	96-99	MST 260			200				
S	125	, Sport	Vespa	07-	MST 260		RAC	200				
X 7	125		M62	08-	MST 393			260	MST 395			240
X 8	125		M36	04-06	MST 393			260	MST 395			240
X 8	125	ie	M36	07	MST 398			260	MST 395			240
X 8	125	Street	M36	06-	MST 398			260				
	150	Fly 4T		05-	MST 260		RAC	200				
	150	Liberty	M67	08-	MST 396			220				
	150	Skipper	CVM	93-97	MST 260		RAC	200				
	150	Skipper	CVM	98-	MST 254			220				
ET4	150		M04	99-	MST 260		RAC	200				
LX	150		Vespa	12-	MST 260		RAC	200				
PX	150	Vespa	Vespa	98-	MST 260		RAC	200				
S	150	, Sport	Vespa	07-	MST 260		RAC	200				
X 8	150	Street	M36	06-	MST 398			260				
GTX	180	Super Hexagon	M20	00	MST 260		RAC	200	MST 260	RAC		200
LXT	180	Hexagon	M06	98-	MST 260		RAC	200				
	200	Beverley	M28	02-07	MST 398			260	MST 398			260
	200	Liberty	M22	07-08	MST 396			220				
PX	200	Vespa PE	Vespa/P200E	98-07	MST 260		RAC	200				
GT	200	Granturismo	Vespa/M31	03-06	MST 396			220	MST 396			220
X 8	200		M36	06	MST 393			260	MST 395			240
	250	Beverley	M28	04-08	MST 398			260	MST 398			260
	250	Carnaby	M60	08-09	MST 398			260	MST 398			260
	250	MP3, EFI	M59	06-09	MST 394			240	MST 395			240
	250	XEvo	M36	07-10	MST 393			260	MST 395			240
GTS	250	ie, ABS	Vespa/M45	06-11	MST 396			220	MST 396			220
GTV	250	ie	Vespa/M45	07-09	MST 396			220	MST 396			220
GTX	250	Super Hexagon	M14	00-02	MST 260		RAC	200	MST 260	RAC		200
GT	250	Hexagon	M14	98-	MST 260		RAC	200				
X 7	250	ie	M62	08-09	MST 393			260	MST 395			240
X 8	250	ie	M36	05-06	MST 393			260	MST 395			240
X 8	250	ie	M36	07	MST 398			260	MST 395			240
X 9	250			04	MST 393			260	MST 395			240
GTS	300	, ie, Super, Touring, Super Sp.	Vespa/M45	10-	MST 396			220	MST 396			220
GTV	300	ie	Vespa	07-	MST 396			220	MST 396			220
	300	Carnaby Cruiser	M60	08-11	MST 398			260	MST 398			260
	300	Carnaby ie		12-	MST 398			260	MST 398			260
	300	MP3 ie, LT ie, YOUrban LT		10-	MST 394			240	MST 395			240
X 7	300	ie		10-	MST 393			260	MST 395			240
	400	Beverley ie	M34	06-07	MST 398			260	MST 395			240
	400	Beverley Tourer ie		08-09	MST 398		*	260	MST 395			240
	400	MP3 ie, LT ie, Touring ie	M59	07-	MST 394		*	240	MST 395			240
	400	Xevo	M52	10-				MST 395				240
X 8	400	ie	M52	06-08	MST 398		*	260	MST 395			240
	500	MP3 EFI, LT ie, Touring ie		09-	MST 394		*	240	MST 395			240
	500	Beverly	M34	02-06	MST 398		*	260	MST 395			240
	500	Beverly ie, Cruiser ie	M34	07-	MST 398		*	260				
X9	500	SL	M27	00-02	MST 398		*	260	MST 395			240
X9	500	Evolution, ABS	M27	03-04	MST 393			260	MST 395			240
X9	500	ie	M27	07	MST 398		*	260	MST 395			240

Royal Enfield

	500	Electra		05-11	MST 233			280				
	500	Clubman EFI		09-	MST 233			280				
	500	Bullet Classic EFI		09-	MST 233			280				
	500	Woodsmen EFI		10-	MST 233			280				
		Trails EFI		09-	MST 233			280				

Sachs

	50	Gipsy	FE053-DE	94-	MST 252		RAC	190				
	50	Reggea			MST 252		RAC	190				
	50	Samba	F052-DE	92-	MST 252		RAC	190				
	50	Splinter	FE053-DE	94-	MST 252		RAC	190				

Sinnis

	50	Falcon	QM50QT-2T	08-	MST 250			155				
	50	Ghost	WY50QT-39A	06-	MST 243		RAC	190				
	50	Jet	QM50QT-6A	08-	MST 250			155				





→ SINNIS

50	Nitro 2T		09-	MST 256					180		
50	Pionier 2T		09-	MST 243		RAC			190		
50	Road Classic		08-	MST 250					155		
50	Strike 2T		09-	MST 256					180		
125	Nitro	WY125T-56A	09-	MST 256					180		
125	Pionier		09-	MST 243		RAC			190		

Suzuki

AP	50	S	CA1JA	94-	MST 263						180
AY	50	Katana	AA	96-98	MST 263						180
AY	50	Katana, Katana R	AA	99-06	MST 263						180
TR	50	street magic	AH	98-99	MST 263						180
UF	50	Estilete	WVBA	00-01	MST 263						180
UX	50	Zillion	AT	99-00	MST 263						180
RM	80			90-01						MST 332	184
RM	85			02-04						MST 332	184
RM	85			05-	MST 318		EC		220	MST 313 RAC	200
UG	110	Hokuto		98-	MST 263					180	
DR	125	SM	CS	08-	MST 307		RAC		250	MST 341	RAC 220
RG	125		NF13	93-	MSW 218				300		
RM	125		RF13A	88-98	MST 311		RAC	EC	250	MST 341	RAC 220
RM	125		RF13A	99-05	MST 311		RAC	EC	250	MST 342	RAC 240
RM	125			06-	MST 311		RAC	EC	250	MST 371 RAC	EC 240
UH	200	Burgmann	CD	07-	MST 437					MST 437	
AN	250	Burgmann	AN	04-07	MST 380				260		
DR	250		SJ45A	95-00	MST 311		RAC	EC	250	MST 341	RAC 220
DR-Z	250			01-07	MST 311		RAC	EC	250	MST 341	RAC 220
GSF	250	Bandit	GJ74A/77A	90-99	MSW 219		RAC		310		
GW	250	Inazuma		12-	MST 460				290	MST 386	RAC 260
LT	250	Quadracer, Quad Sport	LTZ250	85-92	MST 402				160		
RGV	250		VJ21A	89-90	MSW 220		RAC		290		
RGV	250		VJ22B	91-95	MSW 218		*		300		
RM	250		RJ14A	88-98	MST 311		RAC	EC	250	MST 341	RAC 220
RM	250		RJ14A	99-05	MST 311		RAC	EC	250	MST 342	RAC 240
RM	250			06-	MST 311		RAC	EC	250	MST 371 RAC	EC 240
RM-Z	250			04-06	MST 307		RAC		250	MST 339	RAC 240
RM-Z	250			07-	MST 304 RAC		EC		250	MST 305 RAC	EC 240
RMX	250		PJ11A	89-98	MST 311		RAC		250	MST 341	RAC 220
AN	400	Burgmann	WVBW	03-06	MST 380		*		260	MST 381	210
AN	400	Burgmann, Z, ABS	WVCG	07-	MST 380		*		260	MST 381	210
DR-Z	400	E, S	BE/BF/BC	00-05	MST 311		RAC	EC	250	MST 341	RAC 220
DR-Z	400	E, S	WVB8	05-08	MST 311		RAC	EC	250	MST 371 RAC	EC 240
GSF	400	Bandit	GK75A	89-94	MSW 220		*	RAC	290	MST 364	250
GSF	400	Bandit	GK75B	91-95	MSW 219		*	RAC	310	MST 364	250
GSXR	400		GK73A	88-90	MSW 220		*	RAC	290		
GSXR	400		GK76A	90-95	MSW 218		*		300		
LT-Z	400	Quad Sport	LTZ400	02-	MST 402				160	MST 323	220
LT-R	450		LTR450	06-	MST 411				160	MST 412	190
RM-Z	450		RL41C	05-	MST 304 RAC		EC		250	MST 305 RAC	EC 240
RMX	450			10-	MST 304 RAC		EC		250	MST 305 RAC	EC 240
GS	500	F	BK	04-	MSW 219		RAC		310	MST 364	250
GS	500	E/EU	GM51B	89-00	MSW 219		RAC		310	MST 364	250
GS	500	E/EU	WVBK	01-06	MSW 219		RAC		310	MST 364	250
GSF	600	Bandit	GN77B	95-99	MSW 220		*	RAC	290	MST 251	RAC 240
GSF	600	Bandit	WVA8	00-04	MSW 220		*	RAC	290	MST 251	RAC 240
GSR	600		WVB9	06-10	MSW 259		*	RAC	310	MST 251	RAC 240
GSR	600	, ABS	WVB9	06-10	MSW 259		*	RAC	310	MST 386	RAC 260
GSX	600	F	GN72B	89-92	MSW 220		RAC		290		
GSX	600	F	GN72B	93-97	MSW 220		RAC		290	MST 364	250
GSX	600	F	WVAJ	98-02	MSW 220		*	RAC	290	MST 251	RAC 240
GSX	600	F	WVAJ	03-04	MSW 248		*	RAC	290	MST 251	RAC 240
GSXR	600	R	WVAD	97-00	MSW 223		*	RAC	320	MST 246	RAC SL 220
GSXR	600	R	WVBG	01-03	MSW 223		*	RAC	320	MST 246	RAC SL 220
GSXR	600	R	WVB2	04-05	MSW 241		*	RAC	300	MST 246	RAC SL 220
GSXR	600	R	WVCE	06-07	MSW 255 RAC		*		310	MST 246	RAC SL 220
GSXR	600	R	WVCV	08-10	MSW 266 RAC		*		310	MST 246	RAC SL 220
GSXR	600	R	C3	11-	MSW 266 RAC		*		310	MST 246	RAC SL 220
RF	600	R	GN76B	95-97	MSW 220		*	RAC	290	MST 251	RAC 240
VS	600	Intruder	VN51B	95-97	MST 231				295		
AN	650	Burgmann, ABS	WVBU	03-	MST 380		*		260		



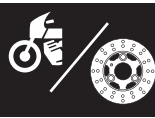
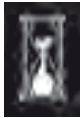

→ **SUZUKI**

DL	650	V-Strom	WVB1	04-07	MSW 250	*	RAC	310	MST 368			260
DL	650	V-Strom, ABS	WVB1	08-11	MSW 259	*	RAC	310	MST 368			260
DL	650	V-Strom ABS	C7	12-	MSW 259	*	RAC	310	MST 368			260
DR	650	R, RS, RSE, RSEU	SP43B	91-95	MST 230					300		
DR	650	R, RU	SP44B	92-96	MST 230					300		
DR	650	SE (fixed disc)	SP46B	96-00	MST 315					290		
GSF	650	Bandit	WVB5	05-06	MSW 248	*	RAC	290	MST 251	RAC		240
GSF	650	Bandit ABS	WVB5	06-	MSW 260 RAC	*		290	MST 386	RAC		240
GSF	650	Bandit	WVCJ	07-08	MSW 259	*	RAC	310	MST 386	RAC		240
GSF	650	Bandit ABS	WVCJ	07-08	MSW 259	*	RAC	310	MST 386	RAC		240
GSF	650	Bandit ABS	WVCZ	09-12	MSW 259	*	RAC	310	MST 386	RAC		240
GSX	650	F, ABS	WVCJ	08-	MSW 259	*	RAC	310	MST 386	RAC		240
SFV	650	Gladius, ABS	WVCX	09-	MSW 260 RAC	*		290	MST 386	RAC		240
SV	650	, S	AV	99-02	MSW 220	*	RAC	290	MST 251	RAC		240
SV	650	, S	WVBY	03-08	MSW 248	*	RAC	290	MST 246	RAC		220
SV	650	, S ABS	WVBY	07-08	MSW 260 RAC	*		290	MST 386	RAC		240
XF	650	Freewind	WVAC	97-01	MST 230					300		
LT-A	700	Kingquad	LTA 700	05-	MST 414					200		
GSR	750	, ABS	C5	11-	MSW 259	*	RAC	310	MST 386	RAC		240
GSX	750		AE	98-02	MSW 218	*		300	MST 251	RAC		240
GSX	750	F	GR78A	89-97	MSW 220	*	RAC	290	MST 364			250
GSX	750	F	AK	98-02	MSW 220	*	RAC	290	MST 251	RAC		240
GSX	750	F	WVAK	03-	MSW 248	*	RAC	290	MST 251	RAC		240
GSXR	750		GR77A/B	88-89	MSW 217	*	RAC	310	MST 251	RAC		240
GSXR	750		GR7AB	90-91	MSW 217	*	RAC	310	MST 251	RAC		240
GSXR	750	W	GR7BB	92-95	MSW 217	*	RAC	310	MST 251	RAC		240
GSXR	750	W	GR7DB	96-99	MSW 223	*	RAC	320	MST 246	RAC	SL	220
GSXR	750	W	WVBD	00-03	MSW 223	*	RAC	320	MST 246	RAC	SL	220
GSXR	750		WVB3	04-05	MSW 241	*	RAC	300	MST 246	RAC	SL	220
GSXR	750		WVCF	06-07	MSW 255 RAC	*		310	MST 246	RAC	SL	220
GSXR	750		WVCW	08-10	MSW 266 RAC	*		310	MST 246	RAC	SL	220
GSXR	750		C4	11-	MSW 266 RAC	*		310	MST 246	RAC	SL	220
LT-A	750	Kingquad	LTA 750	05-	MST 414					200		
VS	750	Intruder GLF, GLP	VR51B	87-91	MST 231					295		
DR	800	S, SU	SR42B/43B	91-98	MST 230					300		
VS	800	Intruder	VS52B	92-00	MST 231					295		
VZ	800	Marauder	AF	97-03	MSW 218					300		
RF	900	R	GT73B	94-97	MSW 219	*	RAC	310	MST 251	RAC		240
DL	1000	V-Strom	WVBS	02-07	MSW 250	*	RAC	310	MST 368			260
GSXR	1000		WVBL	01-02	MSW 223	*	RAC	320	MST 246	RAC	SL	220
GSXR	1000		WVBZ	03-04	MSW 241	*	RAC	300	MST 246	RAC	SL	220
GSXR	1000		WVB6	05-06	MSW 255 RAC	*		310	MST 246	RAC	SL	220
GSXR	1000		WVCL	07-08	MSW 255 RAC	*		310	MST 246	RAC	SL	220
GSXR	1000		WVCY	09-	MSW 266 RAC	*		310	MST 246	RAC	SL	220
SV	1000	, S	WVBX	03-05	MSW 250	*	RAC	310	MST 246	RAC	SL	220
TL	1000	S	AG	97-00	MSW 223	*	RAC	320	MST 246	RAC	SL	220
TL	1000	R	AM	98-99	MSW 223	*	RAC	320	MST 246	RAC	SL	220
GSXR	1100	(K - N)	GV73C	89-92	MSW 217	*	RAC	310	MST 251	RAC		240
GSXR	1100	W	GU75C	93-97	MSW 217	*	RAC	310	MST 251	RAC		240
GSX	1200	FS	A3	99-00	MSW 219	*	RAC	310	MST 251	RAC		240
GSF	1200	Bandit	GV75A	95-00	MSW 219	*	RAC	310	MST 251	RAC		240
GSF	1200	Bandit	WVA9	01-05	MSW 219	*	RAC	310	MST 251	RAC		240
GSF	1200	Bandit, Bandit ABS	WVCB	06	MSW 259	*	RAC	310	MST 386	RAC		240
GSF	1250	Bandit, Bandit ABS	WVCH	07-	MSW 259	*	RAC	310	MST 386	RAC		240
GSX	1250	F, ABS	WVCH	10-	MSW 259	*	RAC	310	MST 386	RAC		240
GSXR	1300	Hayabusa	WVA1	99-07	MSW 223	*	RAC	320	MST 251	RAC		240
GSXR	1300	Hayabusa, ABS	WVCK	08-	MSW 259	*	RAC	310	MST 343 RAC			260
	1300	B-King, ABS	WVCR	08-	MSW 259	*	RAC	310	MST 343 RAC			260
GSX	1400		WVBN	02-	MSW 223	*	RAC	320				
VS	1400	Intruder	VX51L	87-03	MST 231			295	MST 365			278
VZ	1500	M Intruder	WVCU	09-10	MSW 248	*	RAC	290				
VZ	1600	Marauder	VNT60B	04	MSW 216		RAC	320				
VZ	1600	M Intruder	VNT60B	04	MSW 216		RAC	320				
VLR	1800	C1800R, Intruder	WVCT	08-	MSW 248	*	RAC	290				
VZR	1800	M1800R, R2 Intruder	WVCA	06-	MSW 255 RAC	*		310				

SYM

	50	Allo		11-	MST 243		RAC	190				
	50	City Hopper		96-06	MST 241			162				
	50	Fancy	F5L	98-	MST 236		RAC	190				
	50	Fiddle, Fiddle II		08-	MST 243		RAC	190				





→ SYM

50	Jet	G5J	95-	MST 236	RAC	190				
50	Mio	HU05W	05-	MST 241		162				
50	Orbit, Orbit II		08-	MST 243	RAC	190				
50	Pure	F5B-2	98-	MST 236	RAC	190				
50	Red Devil	G5J	97-	MST 236	RAC	190				
50	Super Fancy	F5L	96-06	MST 241		162				
50	Simply		07-	MST 243	RAC	190				
100	Mio		05-	MST 241		162				
100	Super Fancy	F5L	96-	MST 241		162				
100	Jet	G5J	95-	MST 236	RAC	190				
125	Allo		11-	MST 243	RAC	190				
125	Attila	H125D	99-00	MST 241		162				
125	Fiddle		08-	MST 243	RAC	190				
125	Megalo	AK12W	00-07	MST 241		162				
125	Simply		07-	MST 243	RAC	190				
125	SR		99-	MST 241		162				
125	/150 Super Duke	A125Q2-2	99-02	MST 241		162				

TGB

50	Akros Tec		03-04	MST 243	RAC	190				
50	City		07-	MST 243	RAC	190				
50	Delivery/Express		04-	MST 243	RAC	190				
50	High wheel		02-03	MST 243	RAC	190				
50	Trigger		02-03	MST 243	RAC	190				
50	101 R		04-09	MST 243	RAC	190				
50	202 Classic		03-09	MST 243	RAC	190				
50	303 R Hawk/Laser	BR	04-10	MST 243	RAC	190				
50	303 Revolution		02-03	MST 243	RAC	190				
50	409 Cruise		02-03	MST 243	RAC	190				
125	303 Revolution		02-03	MST 243	RAC	190				
125	409 Cruise		02-03	MST 243	RAC	190				

Triumph

600	TT	806AD	00-03	MSW 261 RAC	*	310	MST 245	RAC	SL	220
600	Speed Four	806LB	03-05	MSW 261 RAC	*	310	MST 245	RAC	SL	220
600	Daytona	806AD	03-04	MSW 261 RAC	*	310	MST 245	RAC	SL	220
650	Daytona	865LX	05	MSW 261 RAC	*	310	MST 245	RAC	SL	220
675	Daytona, R	D67LC/H67	06-12	MSW 261 RAC	*	310	MST 245	RAC	SL	220
675	Street Triple	D67LD/L67LR	07-	MSW 261 RAC	*	310	MST 245	RAC	SL	220
800	Tiger XC, ABS	A08	11-	MSW 286	*	320	MST 444			255
885	Speed Triple	T509	97-01	MSW 251	*	320	MST 245	RAC	SL	220
955	Daytona	T509	98-00	MSW 251	*	320	MST 245	RAC	SL	220
955	Daytona	T509	01-06	MSW 279	*	320	MST 245	RAC	SL	220
955	Speed Triple	T595	02-04	MSW 279	*	320	MST 245	RAC	SL	220
955	Sprint RS	T695	99-05	MSW 251	*	320	MST 434			255
955	Sprint ST	T695	99-05	MSW 251	*	320	MST 434			255
1050	Sprint GT	215ND	10-	MSW 276	*	320	MST 434			255
1050	Sprint ST ABS		07-10	MSW 279	*	320	MST 434			255
1050	Sprint ST, ABS, Fgst. 208167-		11-	MSW 276	*	320	MST 434			255
1050	Speed Triple, Fgst. -333178	515NJ	05-07	MSW 278	*	320	MST 436			220
1050	Speed Triple, Fgst. -461331	515NJ	08-10	MSW 276	*	320	MST 436			220
1050	Speed Triple., Fgst. 461332-	515NV	11-	MSW 276	*	320	MST 434			220
1050	Speed Triple ABS	515NV	11-	MSW 276	*	320	MST 434			220
1050	Speed Triple R	515NV	12-	MSW 276	*	320	MST 245	RAC	SL	220
1050	Tiger	115NG	07-	MSW 278	*	320	MST 434			255
1200	Tiger, Explorer XC, ABS		12-	MSW 286	*	320	MST 462			282
1200	Trophy SE, ABS		13-	MSW 276	*	320				

Vertemati

C	500	Cross	501	01-03			MST 321			220
E	500	Enduro	501	01-03			MST 321			220

Vila

AX	50		93-	MST 250		155				
GZ	50		93-	MST 250		155				

Voxan

995	Roadster	V2	01-	MSW 211	*	RAC	320	MST 247	RAC	245
995	Cafe racer	V2	00-	MSW 211	*	RAC	320	MST 247	RAC	245
995	Street Scrambler	SC	03-	MSW 211	*	RAC	320	MST 247	RAC	245
995	Black Magic	BM	04-	MSW 211	*	RAC	320	MST 247	RAC	245



Yamaha

50	BWS-R	4VA	95-	MST 250			155				
EW	Slider	SA09	99-	MST 236		RAC	190				
CS	Jog R/ RR	SA22	02-	MST 236		RAC	190				
CW	Spy	4VA	95-	MST 257			180				
CW	Bump	4VA	96-	MST 257			180				
CW	Next Generation	4VA	95-98	MST 257			180				
BWS	Next Generation	SA05	99-	MST 243		RAC	190				
CW	Booster Spirit	SA05	99-	MST 257			180				
CRZ		3WN	92-95	MST 250			155				
CV	Jog	3WG	91-	MST 250			155				
CV	Jog	SA22	02-	MST 250			155				
TZR		RA03	97-00	MST 233			282				
YA	Axis	3UG	94-96	MST 250			155				
YE	Zest	4FW	93-95	MST 250			155				
YM	Fizz	4RC	94-	MST 250			155				
YM	Breeze	4RC	94-98	MST 250			155				
YN	Neo's	5AD/SA15	97-06	MST 236		RAC	190				
YN	Neo's 2T, 4T	SA15	07-	MST 236		RAC	190				
YQ	Aerox	5BR	97-00	MST 243		RAC	190	MST 243	RAC	190	
YQ	Aerox	SA14	01-	MST 243		RAC	190	MST 243	RAC	190	
YQ	Aerox R, Aerox R Naked	SA14	01-	MST 243		RAC	190	MST 243	RAC	190	
YZ		4LB/CB02	93-01	MST 318			EC 220	MST 348	EC	190	
YZ		CB04	02-03	MST 318			EC 220	MST 348	EC	190	
YZ	/LW	CB07	04-	MST 318			EC 220	MST 348	EC	190	
YN	Neos	SA15	00-03	MST 236		RAC	190				
YQ	Aerox	SB05	00-	MST 243		RAC	190	MST 243	RAC	190	
DT	R	4BL/3RM	88-98	MST 355			230	MST 346		220	
DT	R	DE03	99-03	MST 355			230	MST 346		220	
DT	RE	DE06	04-07	MST 355			230	MST 346		220	
DT	X	DE06	04-	MSW 224			298	MST 346		220	
HW	Xenter		12-	MSW 269							
SR		10F	95-01	MST 248			267				
TDR	Japan		89-	MST 234			282	MST 346		220	
TDR	Italien	4GW	89-	MSW 211		RAC	320	MST 346		220	
TZ	Competition	4JT	94-95	MSW 221		RAC	300				
TZ	Competition	4JT	96-97	MSW 211		RAC	320				
WR			90-92	MST 355			230	MST 346		220	
WR			93-97	MST 316			245	MST 346		220	
WR			98-00	MST 316			245	MST 347		240	
WR			01	MST 311		RAC	EC 250	MST 347		240	
WR			02-04	MST 311		RAC	EC 250	MST 350	RAC	EC 245	
WR			05-07	MST 311		RAC	EC 250	MST 350	RAC	EC 245	
WR	X	DE07	09-	MSW 224		RAC	300	MST 388	RAC	230	
XQ	Maxster	SE05	01-03	MST 370			245				
XV	Virago	5AJ	97-00	MST 233			282				
XVS	Drag Star	VE01	99-04	MST 233			282				
XN	Teo's	SE04	00-03	MST 259			220				
YP	Majesty	SE02	98-06	MST 259			220				
YP	X-Max, ABS	SE32	06-	MSW 269			267	MST 382		240	
YP	X-Max Business ABS	SE54	10-	MSW 269			267	MST 382		240	
YZ		1LX	86	MST 355			230	MST 346		220	
YZ		2HG	87	MST 355			230	MST 346		220	
YZ		2VN	88	MST 355			230	MST 346		220	
YZ		3JD	89	MST 355			230	MST 346		220	
YZ		3SR	90-91					MST 346		220	
YZ		4DB	92	MST 316			245	MST 346		220	
YZ		4EX	93	MST 316			245	MST 346		220	
YZ		4JY	94	MST 316			245	MST 346		220	
YZ		4PE	95	MST 316			245	MST 346		220	
YZ		4SS	96-97	MST 316			245	MST 346		220	
YZ		4XM	98-99	MST 316			245	MST 347		240	
YZ		CE05	00	MST 316			250	MST 347		240	
YZ		CE08	01	MST 311		RAC	EC 250	MST 347		240	
YZ	/LC	CE09	02-	MST 311		RAC	EC 250	MST 350	RAC	EC 245	
YZF	R	RE06	08-	MST 383			292	MST 389			
XQ	Maxster	SG06	01-03	MST 370			245	MST 259		220	
YP	Majesty	SG08	98-	MST 259			220				
YP	Majesty	SG12	03-	MST 259			220				
WR		4BF	98-00	MST 316			245	MST 347		240	
YFS	Blaster	YFS200	88-05					MST 407		220	





→ YAMAHA

YFS	200	Blaster	YFS200	06-	MST 405			161	MST 407		220
TDR	250		3CK	89-90	MSW 211		RAC	320			
TT	250	R	4MR	93-03					MST 346		220
TZ	250		4TW	97	MSW 221		RAC	300			
VP	250	X-City		08-	MST 457			270	MST 382		240
WR	250	Nordamerika	3RB	90-91					MST 346		220
WR	250	Nordamerika	4DC	92-93	MST 316			245	MST 346		220
WR	250		4JW	94-97	MST 316			245	MST 346		220
WR	250		4SR	98-00	MST 316			245	MST 347		240
WR	250		CG	01	MST 311		RAC	EC 250	MST 347		240
WR	250		CG	02-04	MST 311		RAC	EC 250	MST 350	RAC	EC 245
WR	250		CG	05-07	MST 311		RAC	EC 250	MST 350	RAC	EC 245
WR	250	X	DG20	08-	MSW 224		RAC	300	MST 388 RAC		230
WR	250	F	CG	01	MST 311		RAC	EC 250	MST 347		240
WR	250	F	CG	02-12	MST 311		RAC	EC 250	MST 350	RAC	EC 245
XV	250	Virago	3 LW	95-00	MST 233			282			
XVS	250	Dragstar	VG03	01-04	MST 233			282			
YFM	250	X	YFM250	01-04	MST 405			161			
YFM	250	Bruin	YFM250	05-	MST 405			161			
YFM	250	Big Bear	YFM250	07-	MST 405			161			
YFM	250	Raptor	YFM250	08-	MST 405			161			
YP	250	Majesty	4UC	96-	MST 247			245			
YP	250		SG02	96-98	MST 247			245			
YP	250	Majesty de Luxe	SG04	98-	MST 247			245			
YP	250	Skyliner, ABS		00-	MST 247			245			
YP	250	R X-Max	SG16	05-09	MSW 269			267	MST 382		240
YP	250	R X-Max, Sport	SG22	10-	MSW 269			267	MST 382		240
YZ	250		2VM	88-89	MST 355			230	MST 346		220
YZ	250		3SP/3XK	90-91					MST 346		220
YZ	250		4DA	92	MST 316			245	MST 346		220
YZ	250		4EW	93	MST 316			245	MST 346		220
YZ	250		4JX	94	MST 316			245	MST 346		220
YZ	250		4MX	95	MST 316			245	MST 346		220
YZ	250		4SR	96-97	MST 316			245	MST 346		220
YZ	250		4XL	98-00	MST 316			245	MST 347		240
YZ	250		CG	01	MST 311		RAC	EC 250	MST 347		240
YZ	250	/LC	CG	02-	MST 311		RAC	EC 250	MST 350	RAC	EC 245
YZ	250	F	CG	01	MST 311		RAC	EC 250	MST 347		240
YZ	250	F	CG	02-	MST 311		RAC	EC 250	MST 350	RAC	EC 245
RD	350	LC	31K	85-90	MST 248	*	RAC	267	MST 248	RAC	267
RD	350	LC	1WW	86-90	MST 248	*	RAC	267	MST 248	RAC	267
RD	350	LC	1WX	86-90	MST 248	*	RAC	267	MST 248	RAC	267
YFM	350	Warrior	YFM350	92-04	MST 405			161	MST 406		245
YFM	350	Wolverine	YFM350	95-06					MST 407		220
YFM	350	Raptor	YFM350	04-	MST 405			161			
YZF	350	Banshee	YFZ350	87-06	MST 405			161	MST 407		220
YZ	360			89-93					MST 346		220
FZR	400	R	4DX	90-	MSW 221		RAC	300			
SRX	400			91-	MSW 211		RAC	320	MST 247	RAC	245
WR	400	4-T	CH	98	MST 316			245	MST 346		220
WR	400	4-T	CH	99-00	MST 316			245	MST 347		240
WR	400		CH	01	MST 311		RAC	EC 250	MST 347		240
XJR	400	R	4HM	97-	MSW 221	*	RAC	300	MST 247	RAC	245
XVS	400			96-	MSW 235			298			
YFM	400	Grizzly	YFM400	07	MST 405			161			
YP	400	Majesty, ABS	SH05	05-	MSW 269			267	MST 382		240
YZ	400	F	CH	98	MST 316			245	MST 346		220
YZ	400	F	CH	99	MST 316			245	MST 347		240
WR	426	F	CJ	01	MST 311		RAC	EC 250	MST 347		240
WR	426	F	CJ	02	MST 311		RAC	EC 250	MST 350	RAC	EC 245
YZ	426	F	CJ	00	MST 316			245	MST 347		240
YZ	426	F	CJ	01	MST 311		RAC	EC 250	MST 347		240
YZ	426	F	CJ	02	MST 311		RAC	EC 250	MST 350	RAC	EC 245
WR	450	F	CJ	03-	MST 311		RAC	EC 250	MST 350	RAC	EC 245
YFZ	450		AJ11	04-05	MST 405			161			
YFZ	450		YFZ450	06-10	MST 405			161	MST 410		200
YZ	450	F	CJ	03-04	MST 311		RAC	EC 250	MST 350	RAC	EC 245
YZ	450	F	CJ	05-	MST 311		RAC	EC 250	MST 350	RAC	EC 245
YZ	490		2HJ	85-90	MST 355			230	MST 346		220
RD	500	LC,YPVS	47X	84-88	MST 248		RAC	267			





→ YAMAHA

RD	500	LC	1GE	85	MST 248		RAC	267	MST 247	RAC	267
WR	500	(Amerika)	4AA	92-93	MST 355			230	MST 346		220
XP	500	T-Max	SJ03	00-03	MST 234			282	MST 248	RAC	267
XP	500	T-Max	SJ05	04-07	MSW 269			267	MST 248	RAC	267
XP	500	T-Max, ABS	SJ06	08-11	MSW 268			267	MST 248	RAC	267
XP	530	T-Max ABS, Black Max	SJ09	12-	MSW 268			267			
XV	535	Virago	3BR/3YL	91-	MSW 235			298			
XV	535	Virago	3BR/3YL	91-	MSW 224 RAC			298			
XV	535	Virago	VJ01	99-03	MSW 235			298			
XV	535	Virago	VJ01	99-03	MSW 224 RAC			298			
FZR	600		3RG/3RH	89	MSW 221	*	RAC	300	MST 247	RAC	245
FZR	600		3HE	90-94	MSW 221	*	RAC	300	MST 247	RAC	245
FZR	600		4JH/4MH	95-96	MSW 221	*	RAC	300	MST 247	RAC	245
FZS	600	Fazer	RJ02	98-03	MSW 221	*	RAC	300	MST 247	RAC	245
FZ-6	600	Fazer	RJ07	04-06	MSW 246	*	RAC	298	MST 374	RAC	245
FZ-6	600	S2 ABS, Fazer S2 ABS	RJ14	07-09	MSW 246	*	RAC	298	MST 374	RAC	245
SRX	600		1XL/1XM	85-89	MST 248			267	MST 247		245
SRX	600		3SX	90-	MSW 211			320	MST 247		245
TT	600	R	4LW	84-92	MST 355			230			
TT	600	S	4LW/4GV/5CH	93-03	MST 317			267	MST 346		220
XJ	600		51J/3KM	83-91	MST 248	*	RAC	267	MST 248	RAC	267
XJ	600	Diversion S,N	4BR/4LX	92-97	MST 249			320	MST 247	RAC	245
XJ	600	Diversion S,N	RJ01	98-03	MSW 235	*		298	MST 247	RAC	245
XJ	600	Diversion S,N	RJ01	98-03	MSW 224 RAC	*		298	MST 247	RAC	245
XJ6	600	Diversion, ABS	RJ19	09-	MSW 246	*	RAC	298	MST 374	RAC	245
XJ6	600	Diversion F ABS	RJ19/RJ22	10-	MSW 246	*	RAC	298	MST 374	RAC	245
XJ6	600	, SP, ABS	RJ22	13-	MSW 246	*	RAC	298	MST 374	RAC	245
XT	600	H,N	43F/49H	84-87	MST 232			267			
XT	600	Tenere	55W	83-85	MST 232			267			
XT	600	Tenere	1VJ	86-87	MST 232			267			
XT	600	Z, Tenere	3AJ	88-91	MST 232			267	MST 349		220
XT	600		2KF/2NF	87-89	MST 232			267	MST 349		220
XT	600	, E	3TB/3UW	90-94	MST 232			267			
XT	600	, E	3TB/3UW	95-97	MST 234			282			
XT	600	, E	DJ02	98-03	MST 234			282			
YZF	600	R6	RJ03	99-02	MSW 224	*	RAC	300	MST 363		220
YZF	600	R6	RJ05	03-04	MSW 246	*	RAC	298	MST 362	RAC	SL 220
YZF	600	R6	RJ09	05-06	MSW 242	*	RAC	310	MST 362	RAC	SL 220
YZF	600	R6	RJ11	06	MSW 242	*	RAC	310	MST 362	RAC	SL 220
YZF	600	R6	RJ15	07-	MSW 242	*	RAC	310	MST 362	RAC	SL 220
YZF	600	R Thundercat	4TV	96-03	MSW 224	*	RAC	300	MST 247	RAC	245
XVS	650	Drag Star	4VR/XR	97-04	MSW 235			298			
XVS	650	Drag Star	4VR/XR	97-04	MSW 224 RAC			298			
XVS	650	Drag Star classic	VM02	98-00	MSW 235			298			
XVS	650	Drag Star classic	VM02	98-00	MSW 224 RAC			298			
XVS	650	Drag Star classic	VM03	01-03	MSW 235			298			
XVS	650	Drag Star classic	VM03	01-03	MSW 224 RAC			298			
XVS	650	Drag Star classic	VM04	04-07	MSW 235			298			
XVS	650	Drag Star classic	VM04	04-07	MSW 224 RAC			298			
SZR	660		4SU	96-	MSW 211		RAC	320			
MT-03	660		RM02	06-	MSW 246	*	RAC	298	MST 374	RAC	245
XT	660	R	DM01	04-	MSW 224		RAC	298	MST 247	RAC	245
XT	660	X	DM01	04-	MSW 271			320	MST 247	RAC	245
XT	660	X Tenere	DM01	08-	MSW 224		RAC	298	MST 247	RAC	245
XT	660	Z, Tenere	DM02/04	08-	MSW 224	*	RAC	298	MST 247	RAC	245
XTZ	660	Z, Tenere	3YF/4MD	91-99	MST 234			282	MST 349		220
YFM	660	Raptor	AM01	01-05	MST 405			161	MST 407		220
YFM	700	Raptor	AM07	06-	MST 405			161	MST 410		200
YFM	700	Grizzly	YFM700	07-	MST 416			220	MST 417		205
FZ	750	Genesis	1FN	85	MST 248	*	RAC	267	MST 248	RAC	267
FZ	750	Genesis	2KK	86-88	MST 248	*	RAC	267	MST 248	RAC	267
FZ	750	Genesis	3KT/2KK	89-92	MSW 221	*	RAC	300	MST 248	RAC	267
FZX	750	Fazer	2 JE	87-90	MST 248	*		267	MST 248	RAC	267
XTZ	750	H, N	3LD/3WN	89-99	MST 369	*		240	MST 369		240
XV	750	Virago	4FY	-93	MST 248		RAC	267			
XV	750	Virago	4PW	94-97	MST 233			282			
YZF	750	R, SP	4HN/4HT	93-97	MSW 222	*		320	MST 247	RAC	245
YZF	750	R 7	RM01	99-	MSW 262 RAC	*		320	MST 247	RAC	245
FZ8	800	Fazer 8, ABS	RN25	10-	MSW 242	*	RAC	310	MST 423		276
TDM	850		3VD/4TX	91-01	MSW 221	*	RAC	300	MST 247	RAC	245





→ **YAMAHA**

TRX	850		4UN	96-00	MSW 221	*	RAC	300	MST 247	RAC	245
TDM	900		RN08/RN11	02-05	MSW 224	*	RAC	300	MST 247	RAC	245
TDM	900	, ABS	RN18	06-10	MSW 224	*	RAC	300	MST 247	RAC	245
TDM	900	ABS		11-	MSW 224	*	RAC	300	MST 248	RAC	267
XJ	900		31A	83-84	MST 248	*	RAC	267	MST 248	RAC	267
XJ	900	F	58L/4BB	85-94	MST 248	*	RAC	267	MST 248	RAC	267
XJ	900	S Diversion	4KM	94-	MST 264	*		320	MST 248	RAC	267
FZR	1000	Genesis	2LA	87-88	MSW 211	*	RAC	320	MST 248	RAC	267
FZR	1000	EXUP	3LE	89-90	MSW 211	*	RAC	320	MST 248	RAC	267
FZR	1000	EXUP	3LE	91-93	MSW 211	*	RAC	320	MST 248	RAC	267
FZR	1000	EXUP	3LE	94-95	MSW 222	*		320	MST 248	RAC	267
FZS	1000	Fazer	RN06/RN14	01-04	MSW 224	*	RAC	300	MST 248	RAC	267
FZ1	1000	, Fazer, ABS	RN16	06-	MSW 247	*	RAC	320	MST 374	RAC	245
GTS	1000		4BH	93-					MST 233		282
YZF	1000	R1	RN01	98-99	MSW 224	*	RAC	300	MST 247	RAC	245
YZF	1000	R1	RN04	00-01	MSW 224	*	RAC	300	MST 247	RAC	
YZF	1000	R1	RN09	02-03	MSW 224	*	RAC	300	MST 363		220
YZF	1000	R1	RN12	04-06	MSW 247	*	RAC	320	MST 362	RAC	SL 220
YZF	1000	R1	RN19	07-08	MSW 242	*	RAC	310	MST 362	RAC	SL 220
YZF	1000	R1	RN22	09-11	MSW 242	*	RAC	310	MST 362	RAC	SL 220
YZF	1000	R1, TCS	RN22	12-	MSW 209 RAC	*		310	MST 362	RAC	SL 220
YZF	1000	Thunderace	4 VD	96-02	MSW 224	*	RAC	300	MST 247	RAC	245
BT	1100	Bulldog	RP05	02-06	MSW 224	*	RAC	300	MST 248	RAC	267
FJ	1100		47E	84-85	MST 233	*		282	MST 233		282
XV	1100	Virago	3LP	89-93	MST 248	*	RAC	267			
XV	1100	Virago	3LP	94-99	MST 233	*		282			
XVS	1100	Drag Star	VP05	99-04	MSW 235	*		298	MST 233		282
XVS	1100	Drag Star	VP05	99-04	MSW 224 RAC	*		298	MST 233		282
XVS	1100	Drag Star classic	VP05	00-	MSW 235	*		298	MST 233		282
XVS	1100	Drag Star classic	VP05	00-	MSW 224 RAC	*		298	MST 233		282
XVS	1100	Drag Star classic	VP16	03-	MSW 235	*		298	MST 233		282
XVS	1100	Drag Star classic	VP16	03-	MSW 224 RAC	*		298	MST 233		282
FJ	1200		1XJ	86-87	MST 233	*		282	MST 233		282
FJ	1200		3CW	88-89	MSW 221	*	RAC	300	MST 233		282
FJ	1200		3CX/3GP	90-	MSW 221	*	RAC	300	MST 233		282
FJ	1200		3YA / 3XW	91-96	MSW 221	*	RAC	300	MST 233		282
FJ	1200	ABS	3YA	91-96					MST 233		282
VMX	1200	V-max	1FK/1JH/2EN	86-92	MST 233	*		282	MST 233		282
VMX	1200	V-max	2WF/2LT/2EN	93-94	MST 233	*		282	MST 233		282
VMX	1200	V-Max	2WE/2LT/2EN	95-03	MSW 224	*	RAC	300	MST 233		282
XJR	1200		4PU	96-98	MSW 211	*	RAC	320	MST 248		267
XT	1200	Z, Super Tenere, ABS	DP01	10-	MSW 242	*	RAC	310	MST 432		282
XVZ	1200	12 T,TD	47G	84-87	MSW 235	*		298			
XVZ	1200	12 T,TD	47G	84-87	MSW 224	*	RAC	298			
XVZ	1200	Venture Royal	47G	84-90	MST 233	*		282	MST 233		282
FJR	1300		RP04	01-02	MSW 224	*	RAC	300	MST 233		282
FJR	1300	, ABS	RP08/RP11	03-05	MSW 262 RAC	*		320	MST 233		282
FJR	1300	A, AS, ABS	RP13	06-	MSW 262 RAC	*		320	MST 233		282
XJR	1300	Italy	5E1A	99-	MSW 211	*	RAC	320			
XJR	1300		RP02	99-01	MSW 224	*	RAC	300	MST 248	RAC	267
XJR	1300		RP06	02-03	MSW 224	*	RAC	300	MST 248	RAC	267
XJR	1300		RP10	04-06	MSW 224	*	RAC	300	MST 248	RAC	267
XJR	1300		RP19	07-	MSW 224	*	RAC	300	MST 248	RAC	267
XVZ	1300	A Midnight Star	VP2	07-	MSW 224	*	RAC	300			
XVZ	1300	Venture Royal	3JS	88-93	MST 233	*		282			
XVZ	1300	Royal Star	4YP	96-00	MSW 235	*		298	MST 249		320
XVZ	1300	Royal Star	4YP	96-00	MSW 224 RAC	*		298	MST 249		320
XVZ	1300	A	4YP	97-99	MST 233	*		282			
XVZ	1300	13 TF Wild Star	VP09	99-	MSW 235	*		298	MST 249		320
XVZ	1300	13 TF Wild Star	VP09	99-	MSW 224 RAC	*		298	MST 249		320
XVZ	1600	Wild Star	VP08	99-04	MSW 235	*		298			
XVZ	1600	Wild Star	VP08	99-04	MSW 224 RAC	*		298			
MT-01	1670		RP12	05-06	MSW 262 RAC	*		320	MST 248	RAC	267
MT-01	1670		RP18	07-09	MSW 273 RAC	*		320	MST 248	RAC	267
XV-Y	1700	V-max ABS	RP21	09-	MSW 247	*	RAC	320	MST 433 RAC		298
XV	1700	Road Star Warrior	VP14	03-	MSW 224	*	RAC	300	MST 233		282
XV	1900	Midnight Star	VP23	06-	MSW 224	*	RAC	300			

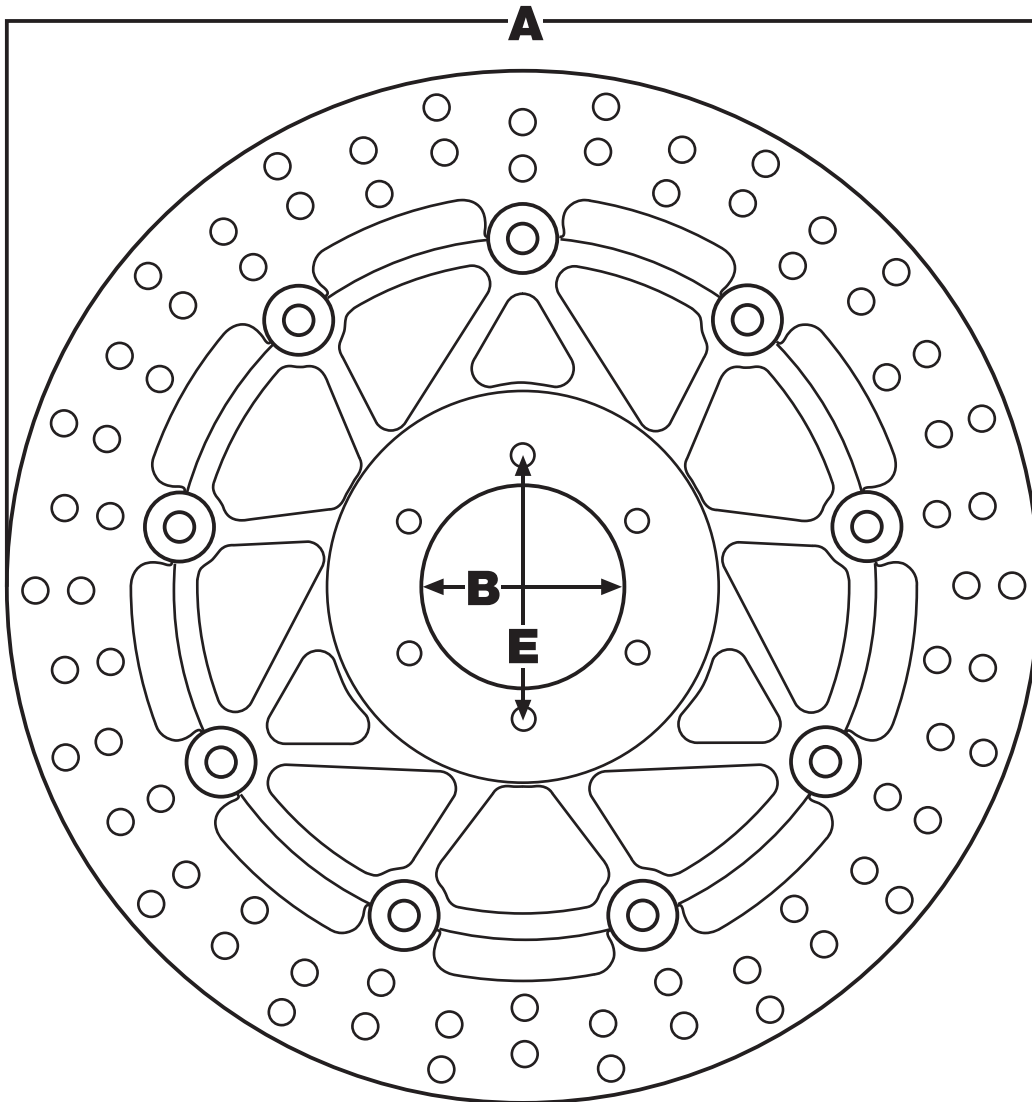
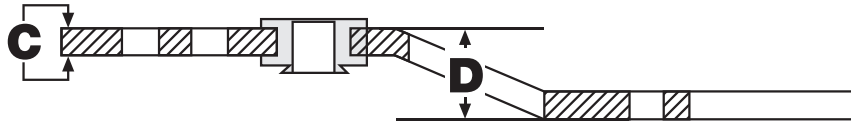



MST 201

A	B	C	D	E
256	144	4		166

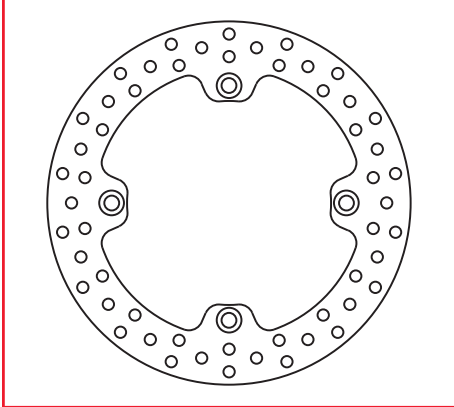

MST 202

A	B	C	D	E
276	144	5		166

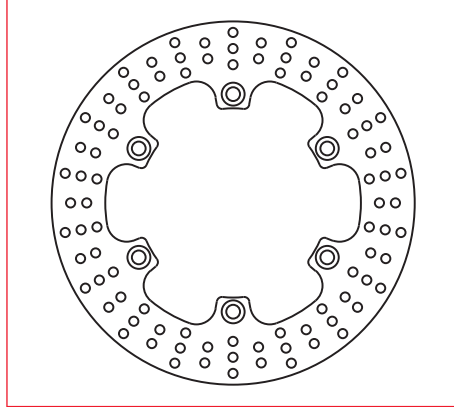

MST 203

A	B	C	D	E
296	144	5		166

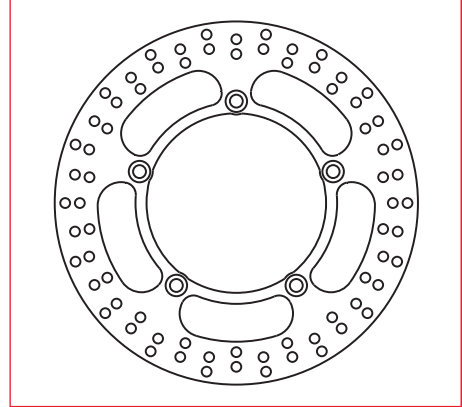

MST 204

A	B	C	D	E
276	144	4		166

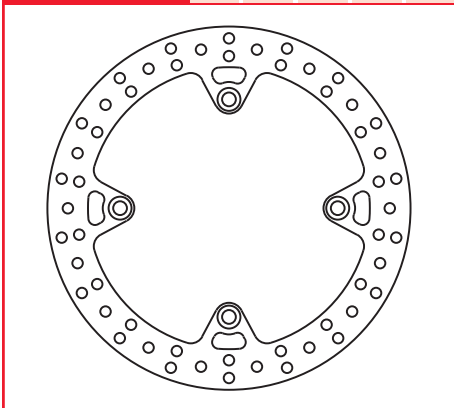

MST 205

A	B	C	D	E
276	144	5		166

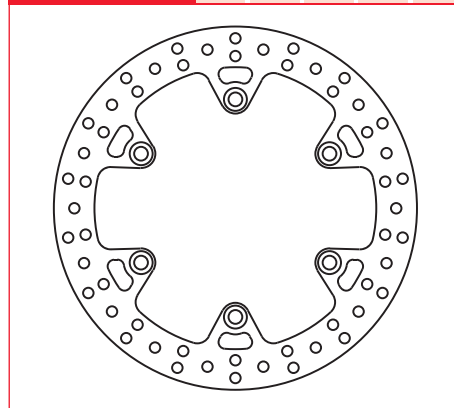

MST 206

A	B	C	D	E
296	144	5		166

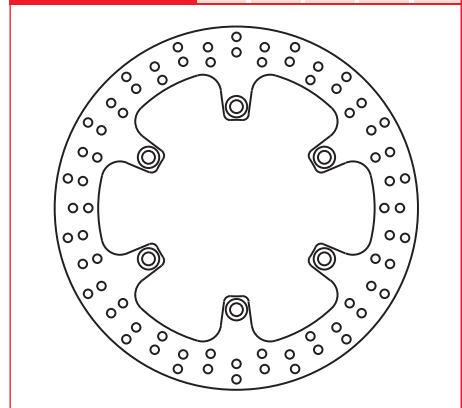

MST 206 RAC

A	B	C	D	E
296	144	5		166

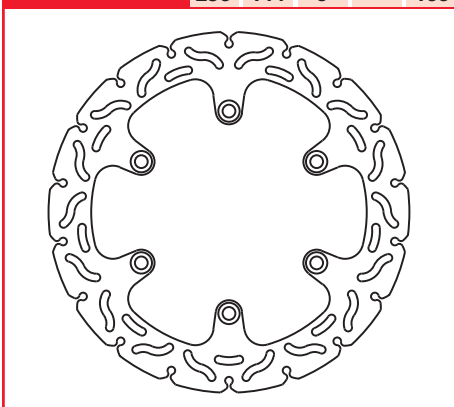

MST 207

A	B	C	D	E
318	144	5		166

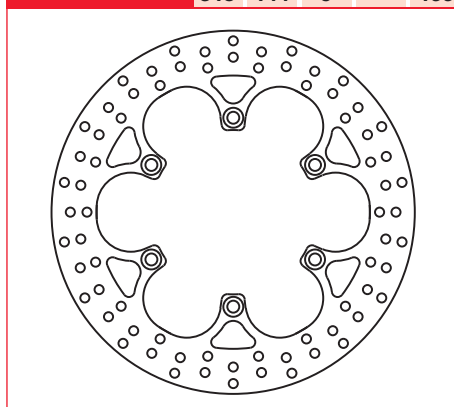

MST 210

A	B	C	D	E
300	130	5		150

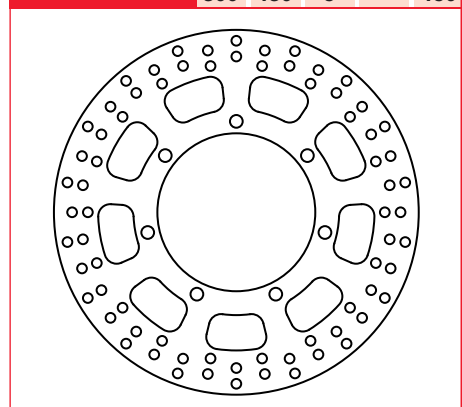

MST 230

A	B	C	D	E
300	121	4		142

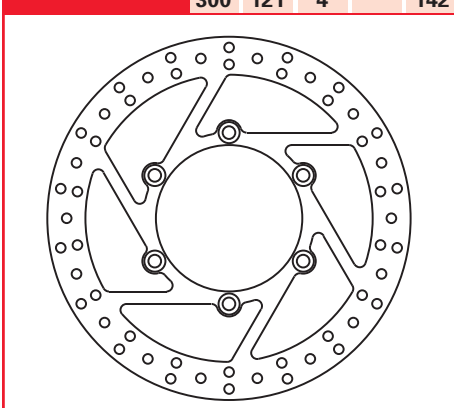

MST 231

A	B	C	D	E
295	57	5		78

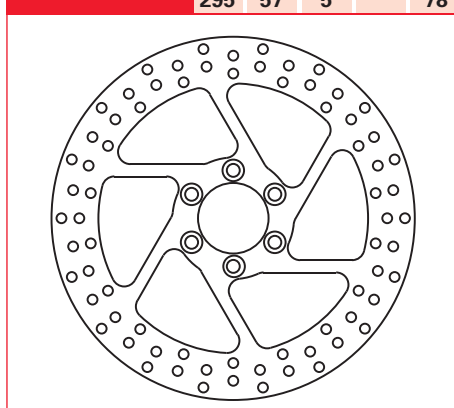

MST 232

A	B	C	D	E
267	132	4		150

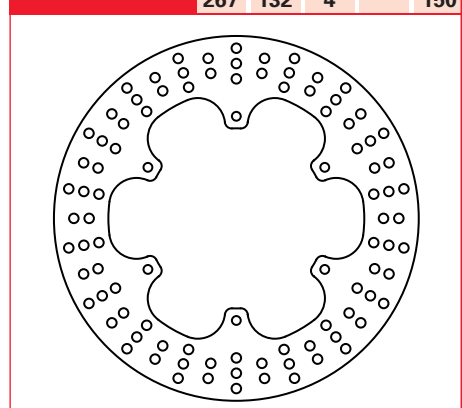

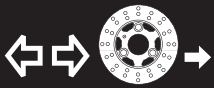

MST 233

A	B	C	D	E
282	132	5		150

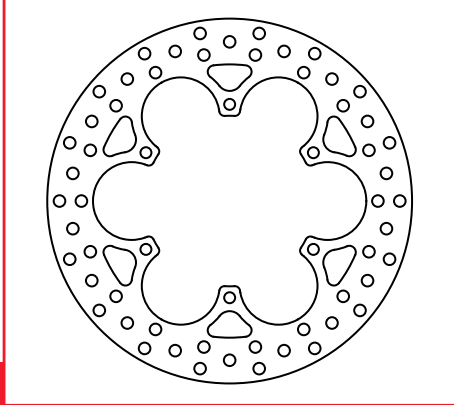

MST 234

A	B	C	D	E
282	132	5		150

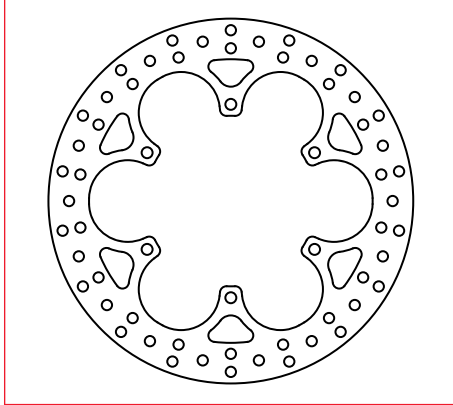

MST 236

A	B	C	D	E
190	58	4		80

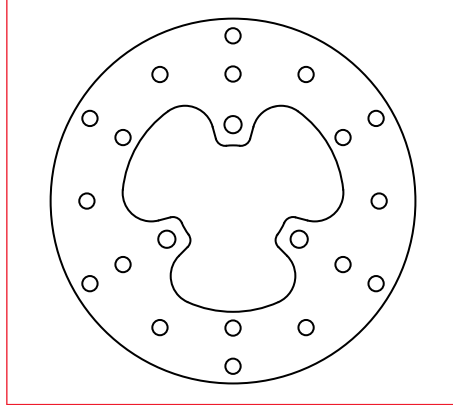

MST 236 RAC

A	B	C	D	E
190	58	4		80

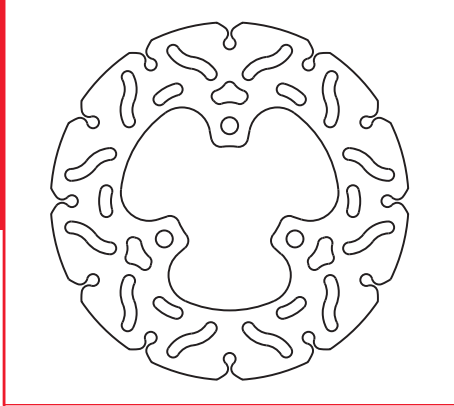

MST 238

A	B	C	D	E
305	181	4,5		202,5

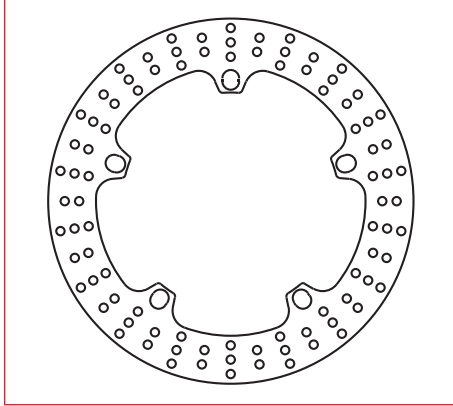

MST 238 RAC

A	B	C	D	E
305	181	4,5		202,5

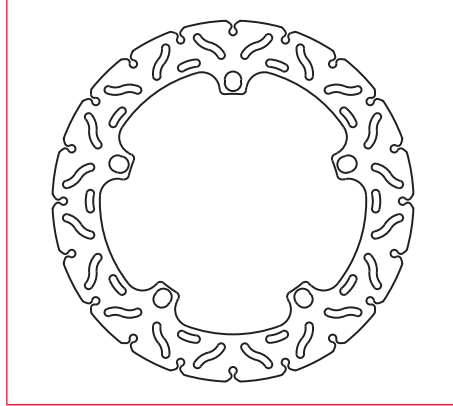

MST 239

A	B	C	D	E
305	181	5		202,5

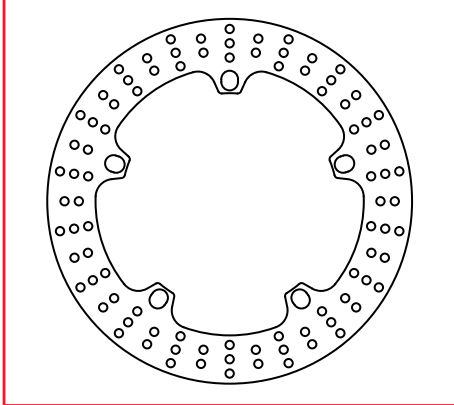

MST 239 FS

A	B	C	D	E
305	181	5		202,5

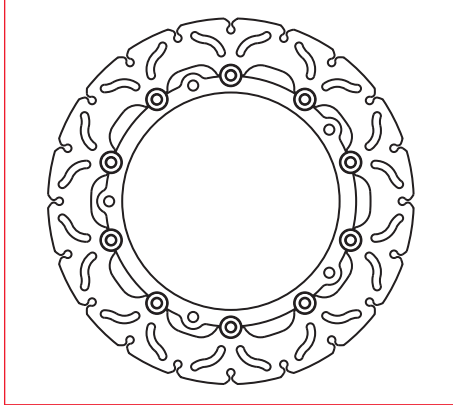

MST 239 RAC

A	B	C	D	E
305	181	5		202,5

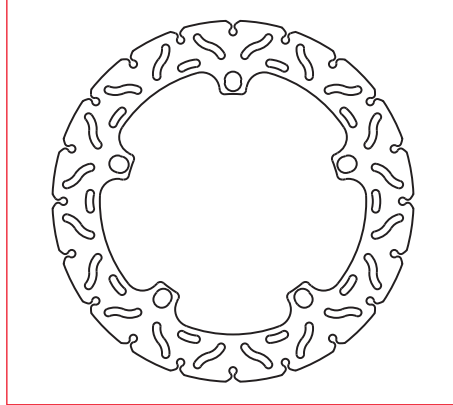

MST 240

A	B	C	D	E
240	105	5		125

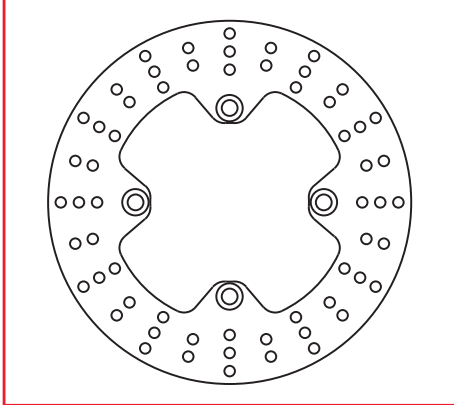

MST 240 RAC

A	B	C	D	E
240	105	5		125

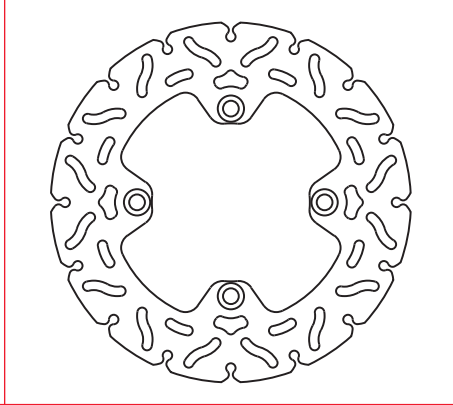

MST 241

A	B	C	D	E
160	58	3		80

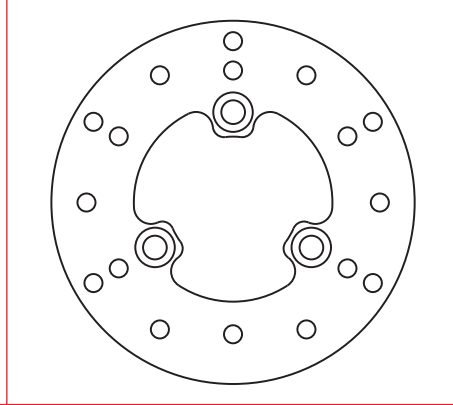



MST 243

A	B	C	D	E
190	58	4		80

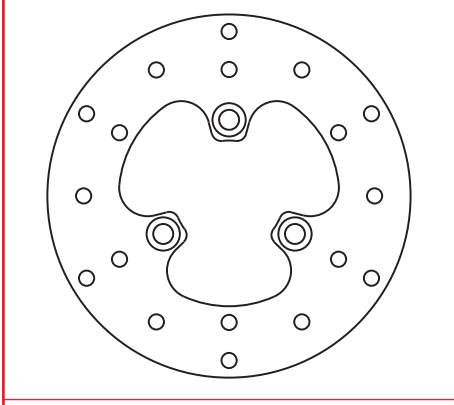

MST 243 RAC

A	B	C	D	E
190	58	4		80

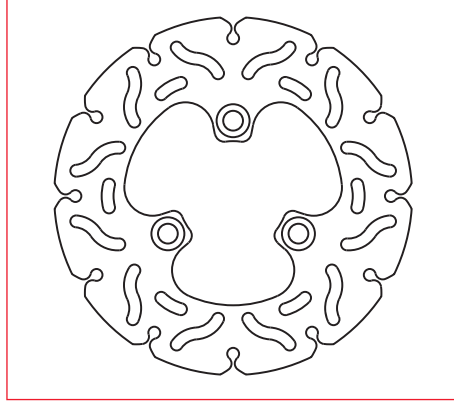

MST 245

A	B	C	D	E
220	105	5		125

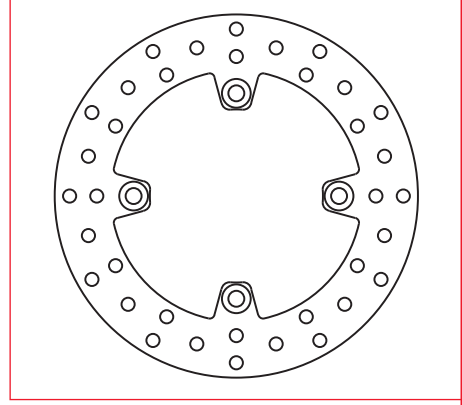

MST 245 RAC

A	B	C	D	E
220	105	5		125

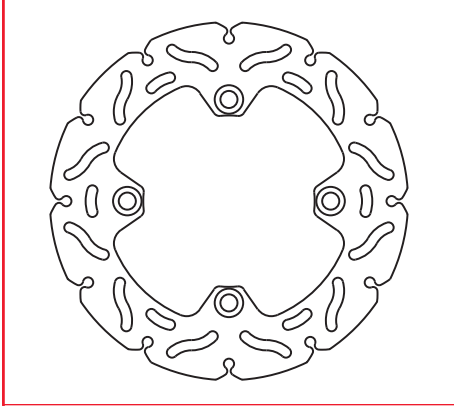

MST 245 SL

A	B	C	D	E
220	105	4		125

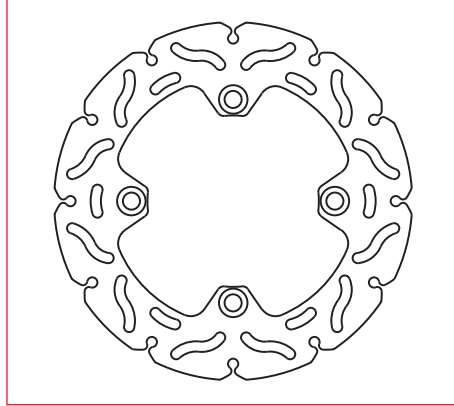

MST 246

A	B	C	D	E
220	89	5		110

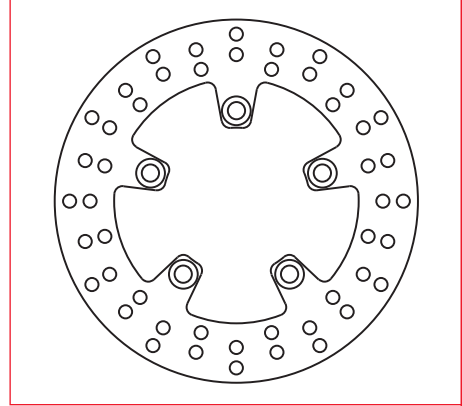

MST 246 RAC

A	B	C	D	E
220	90	5		110

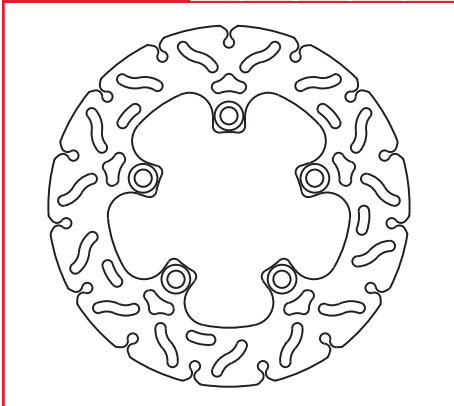

MST 246 SL

A	B	C	D	E
220	90	4		110

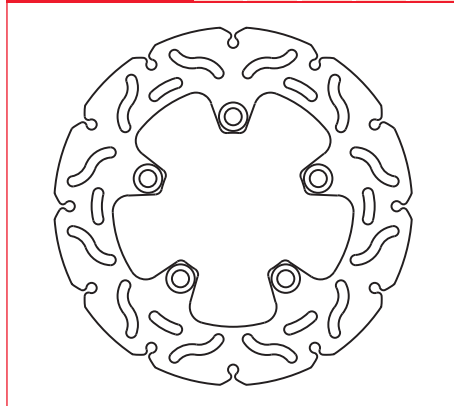

MST 247

A	B	C	D	E
245	115	5		133

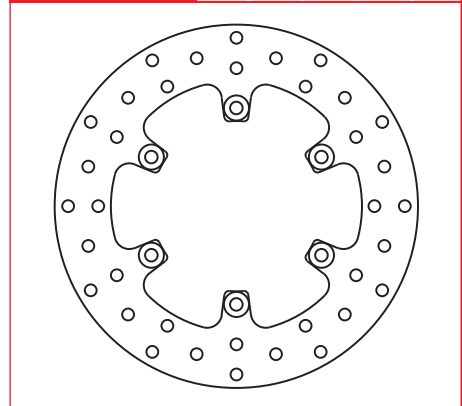

MST 247 RAC

A	B	C	D	E
245	115	5		133

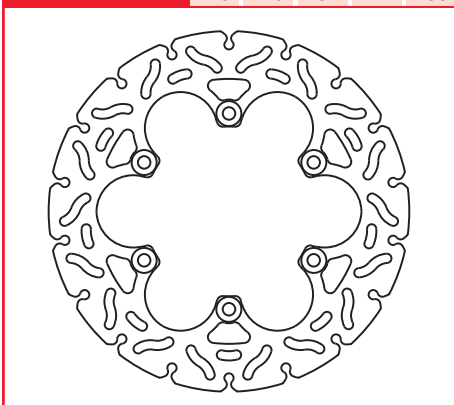

MST 248

A	B	C	D	E
267	132	5		150

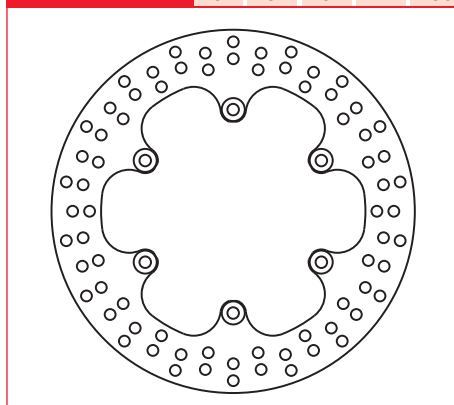

MST 248 RAC

A	B	C	D	E
267	132	5		150

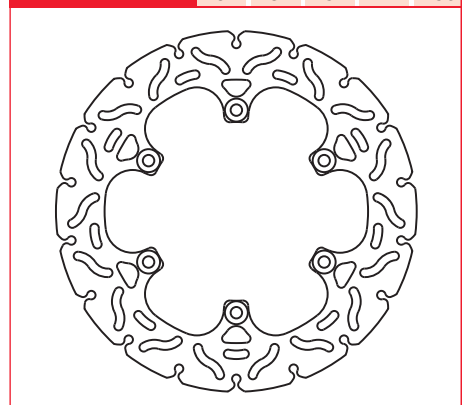



MST 249

A	B	C	D	E
320	198	5		216

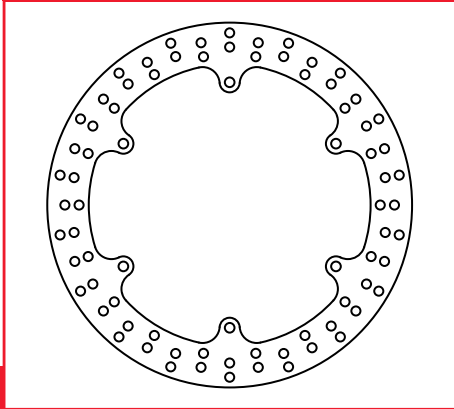

MST 250

A	B	C	D	E
155	41	3		66

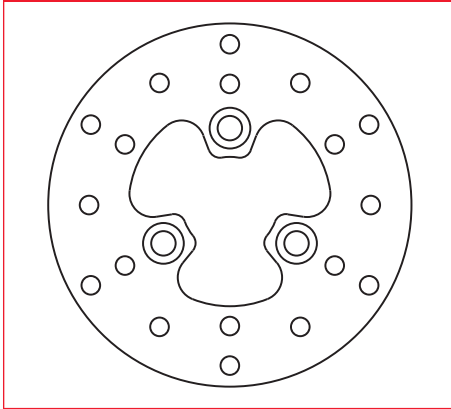

MST 251

A	B	C	D	E
240	89	5		110

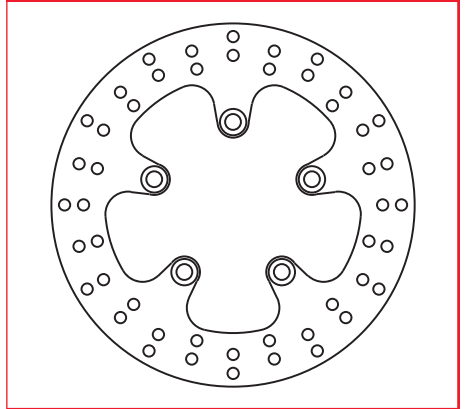

MST 251 RAC

A	B	C	D	E
240	89	5		110

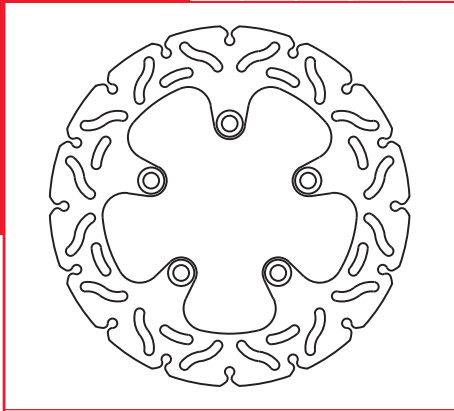

MST 252

A	B	C	D	E
190	58	4		80

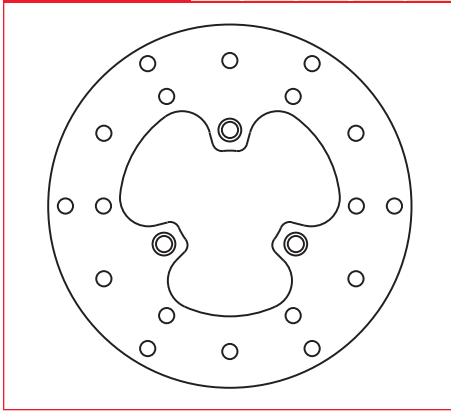

MST 252 RAC

A	B	C	D	E
190	58	4		80

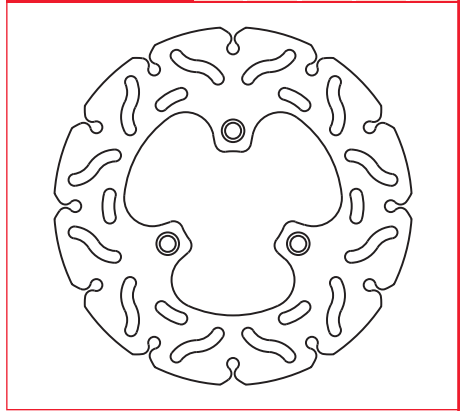

MST 253

A	B	C	D	E
220	60	4		80

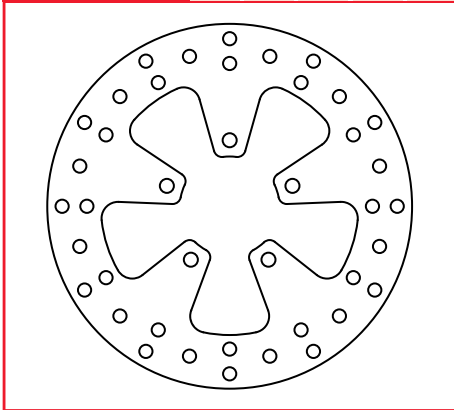

MST 254

A	B	C	D	E
220	58	3		80

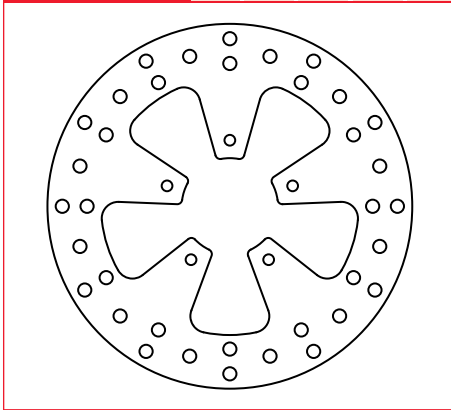

MST 255

A	B	C	D	E
175	73	4		86

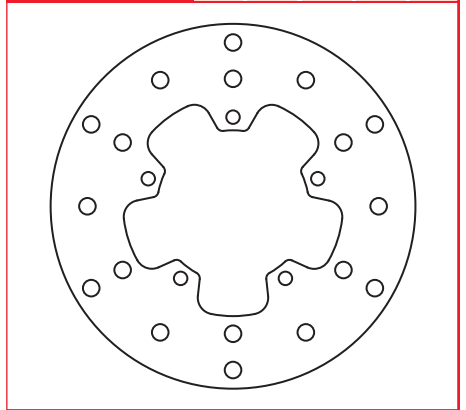

MST 256

A	B	C	D	E
180	60	4		80

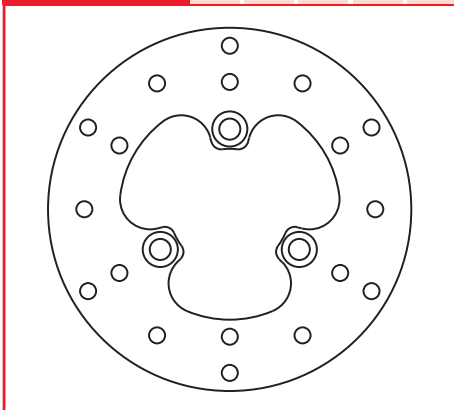

MST 257

A	B	C	D	E
180	48	3		66

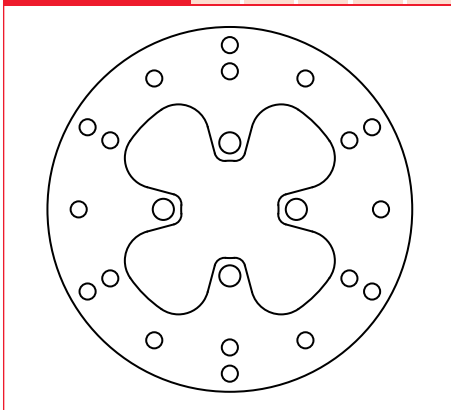

MST 258

A	B	C	D	E
155	39	3		60

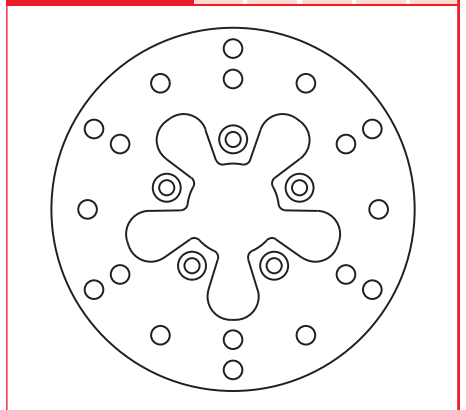



MST 259

A	B	C	D	E
220	57	4		76,5

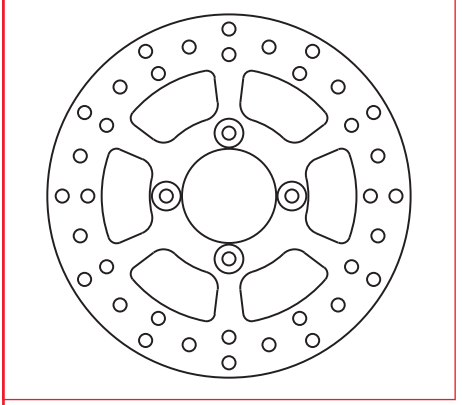

MST 260

A	B	C	D	E
200	98	4		109

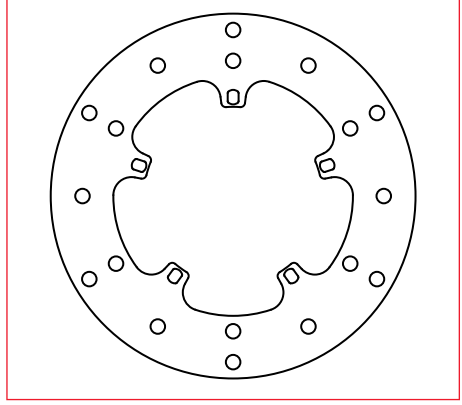

MST 260 RAC

A	B	C	D	E
200	98	4		109

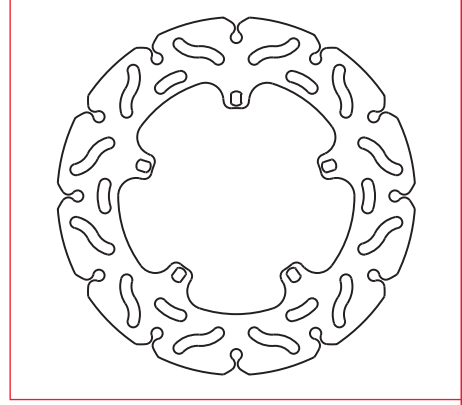

MST 261

A	B	C	D	E
180	58	3		80

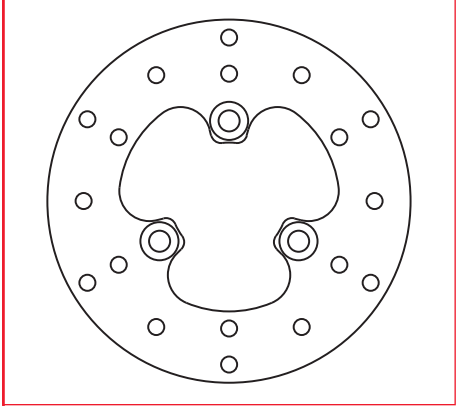

MST 261 RAC

A	B	C	D	E
180	58	3		80

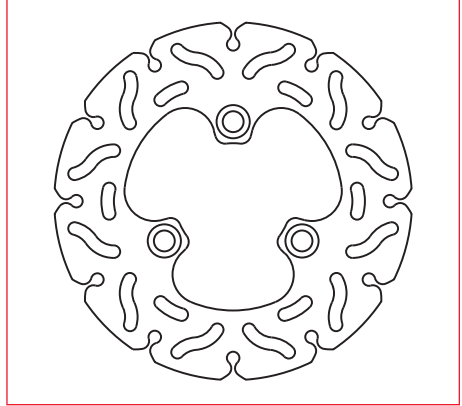

MST 263

A	B	C	D	E
180	34	4		56

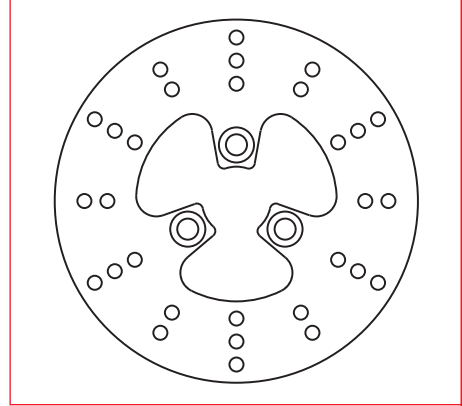

MST 264

A	B	C	D	E
320	198	4		216

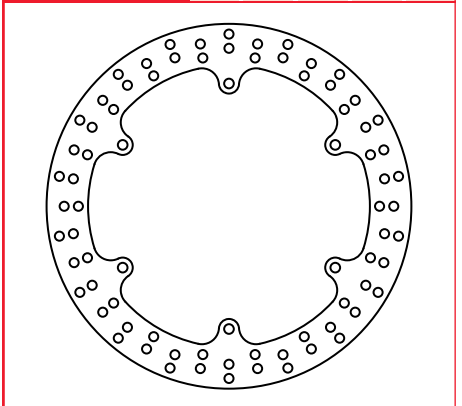

MST 265

A	B	C	D	E
260	126,5	3		143

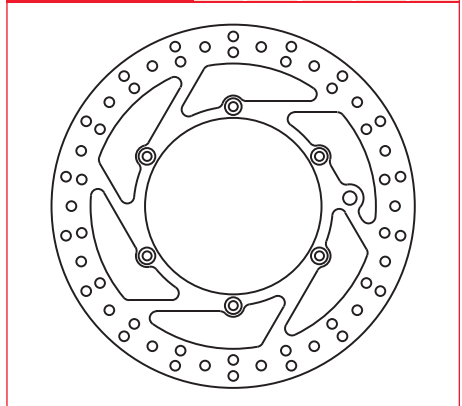

MST 265 EC

A	B	C	D	E
260	126,5	3		143

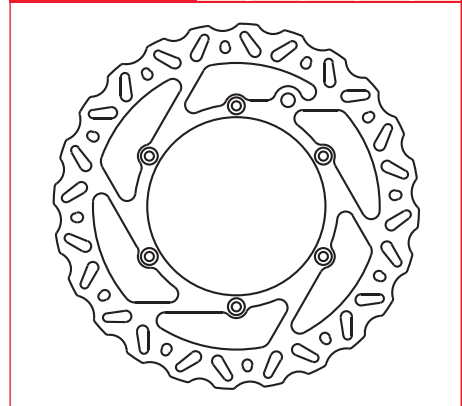

MST 265 RAC

A	B	C	D	E
260	126,5	3		143

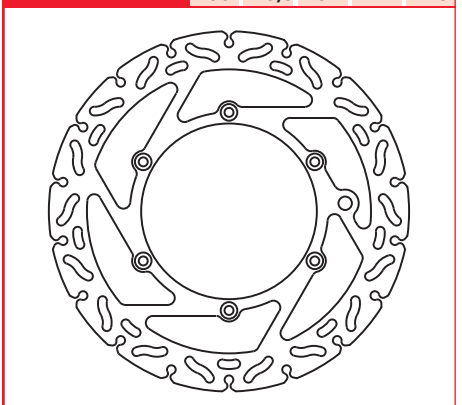

MST 266

A	B	C	D	E
220	110	4		125

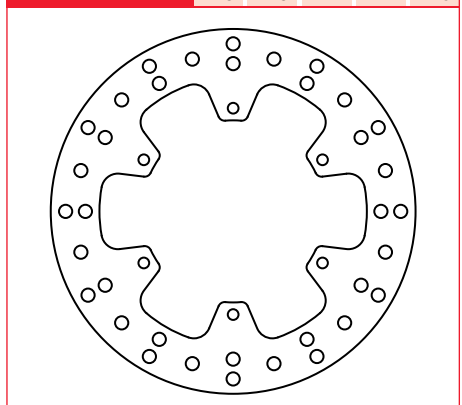

MST 266 EC

A	B	C	D	E
220	110	4		125

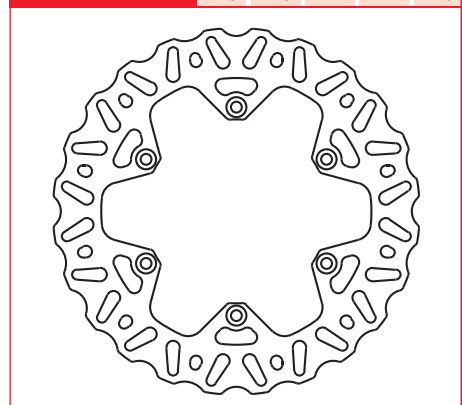



MST 266 RAC

A	B	C	D	E
220	110	4		125

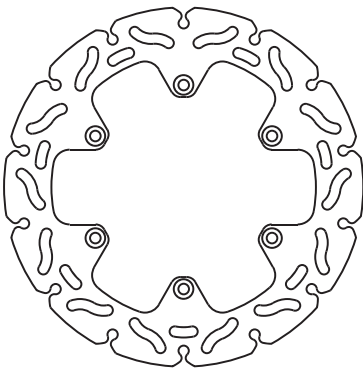

MST 300

A	B	C	D	E
240	118	3		134

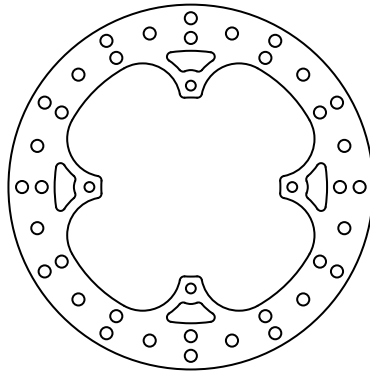

MST 301

A	B	C	D	E
240	101	3		117

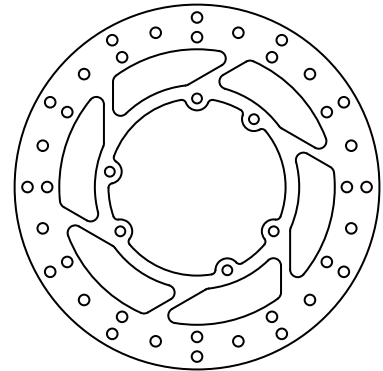

MST 301 EC

A	B	C	D	E
240	101	3		117

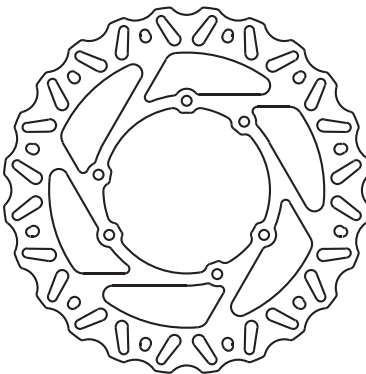

MST 301 RAC

A	B	C	D	E
240	101	3		117

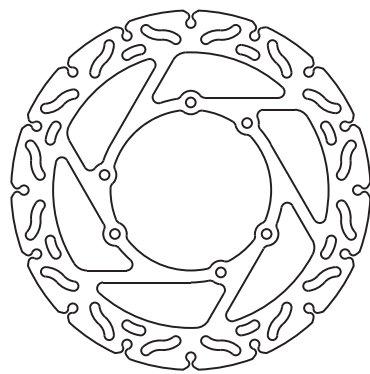

MST 301 ROV

A	B	C	D	E
270	101	3		117

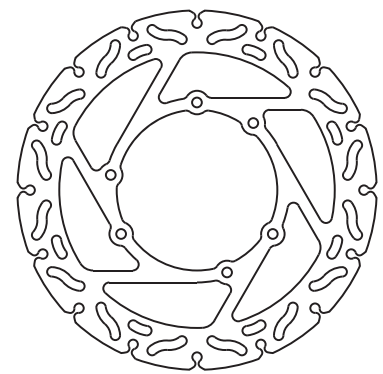

MST 302

A	B	C	D	E
220	88	3		106

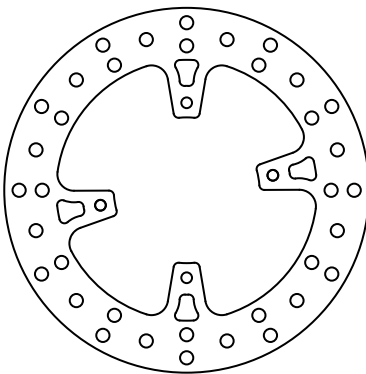

MST 302 EC

A	B	C	D	E
220	88	3		106

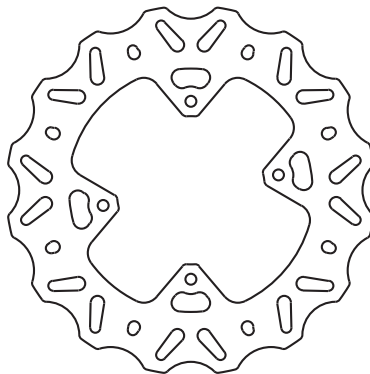

MST 303

A	B	C	D	E
260	108	3		125

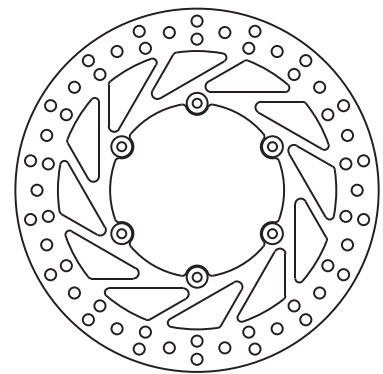

MST 304 EC

A	B	C	D	E
250	118	3		134

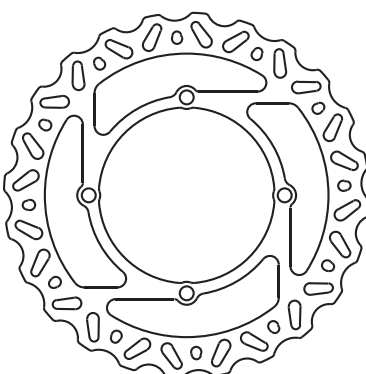

MST 304 RAC

A	B	C	D	E
250	118	3		134

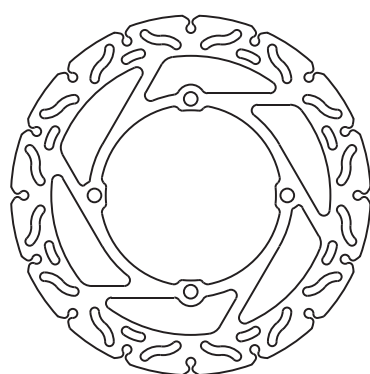

MST 305 EC

A	B	C	D	E
240	122	4		140

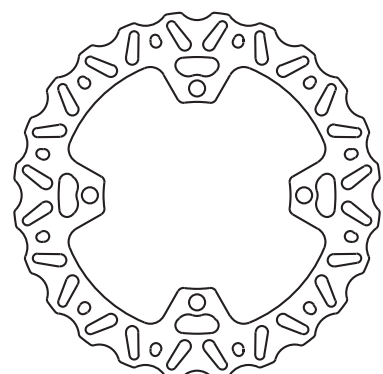



MST 305 RAC

A	B	C	D	E
240	122	4		140

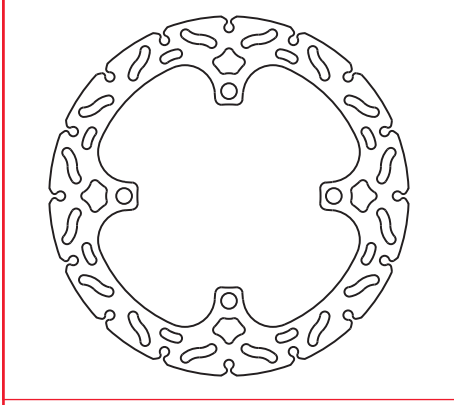

MST 306

A	B	C	D	E
250	100	3		116

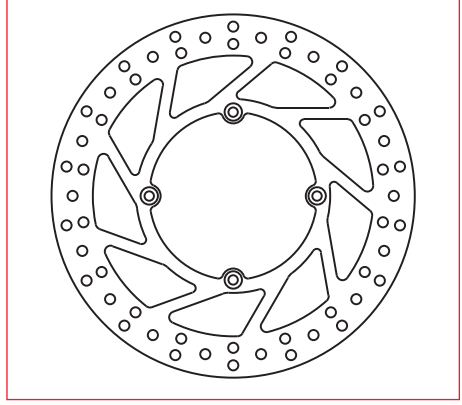

MST 307

A	B	C	D	E
250	100	3		116

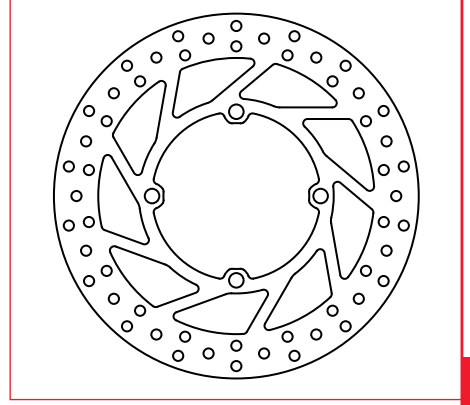

MST 307 RAC

A	B	C	D	E
250	100	3		116

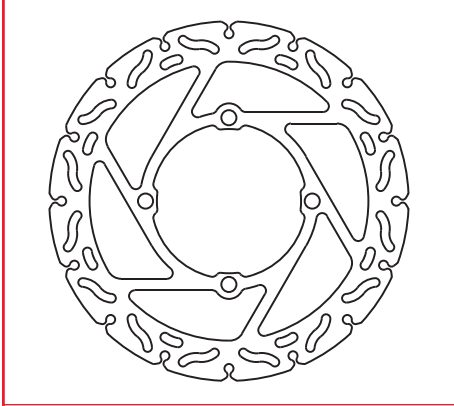

MST 308 EC

A	B	C	D	E
250	109	3		126

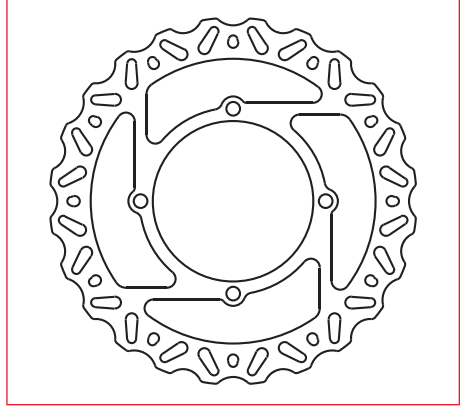

MST 308 RAC

A	B	C	D	E
250	109	3		126

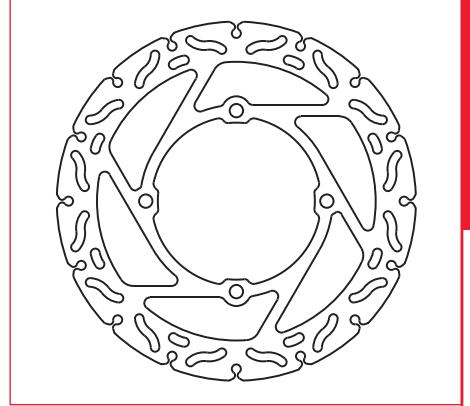

MST 309 EC

A	B	C	D	E
218,5	95	3		110

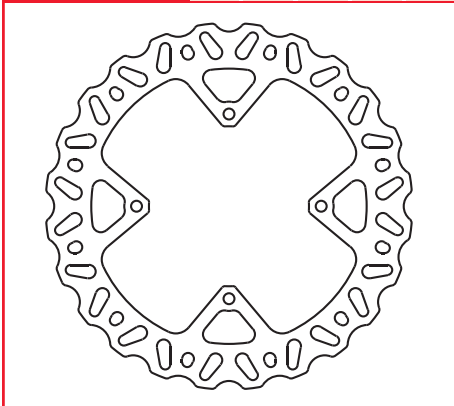

MST 309 RAC

A	B	C	D	E
218,5	95	3		110

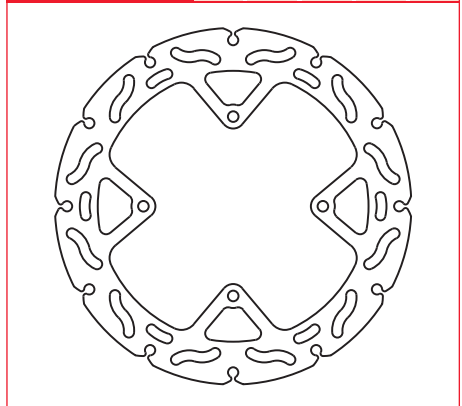

MST 310

A	B	C	D	E
300	126,5	5		143

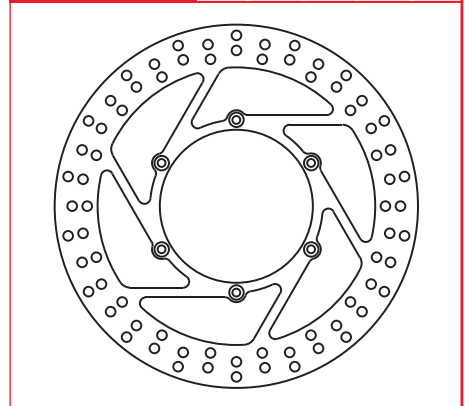

MST 311

A	B	C	D	E
250	118	3		134

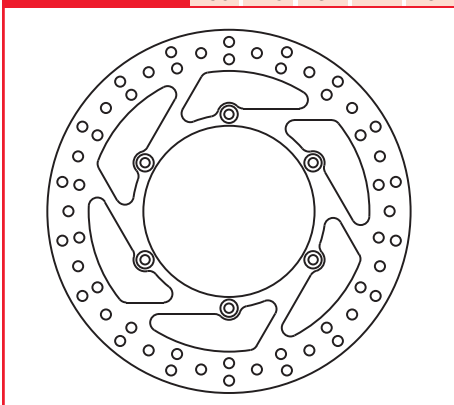

MST 311 EC

A	B	C	D	E
250	118	3		134

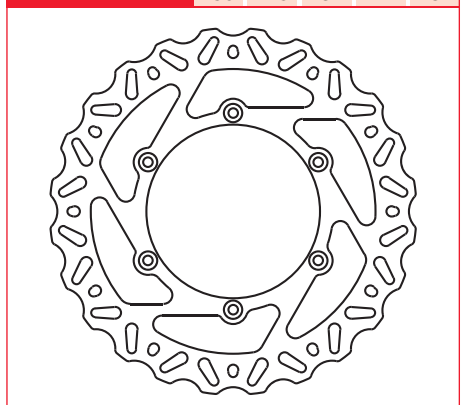

MST 311 RAC

A	B	C	D	E
250	118	3		134



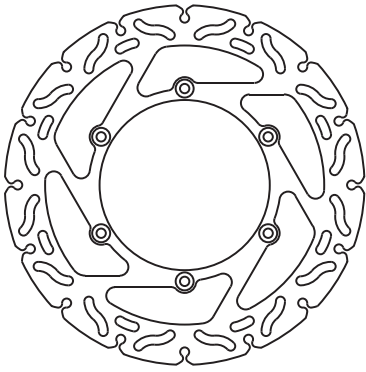

MST 311 ROV

A	B	C	D	E
270	118	3		134

MST 312 RAC

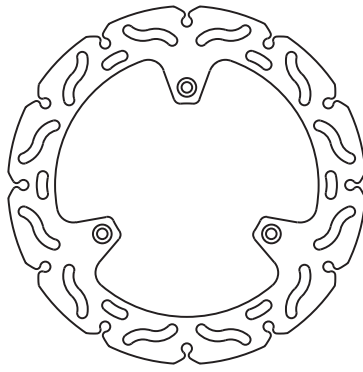
A	B	C	D	E
220	100	3		120

MST 313 RAC

A	B	C	D	E
200	84,5	3		100

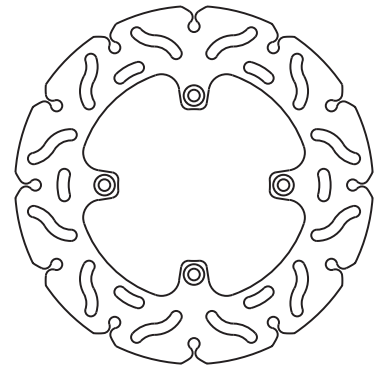
MST 314 EC

A	B	C	D	E
200	110	3		125

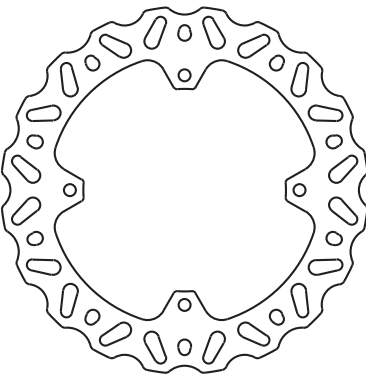
MST 314 RAC

A	B	C	D	E
200	110	3		125

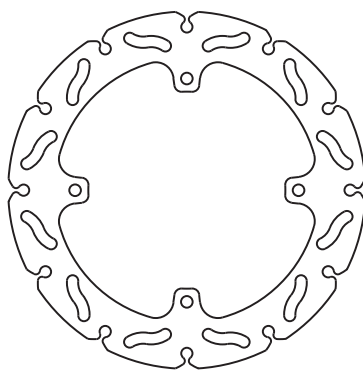
MST 315

A	B	C	D	E
290	121	4		142

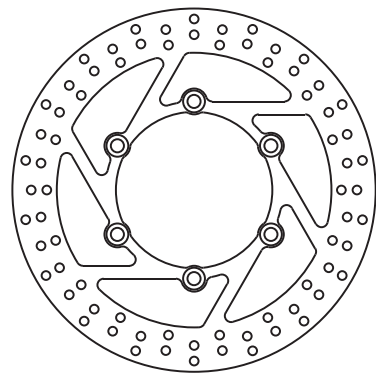
MST 316

A	B	C	D	E
245	118	3		134

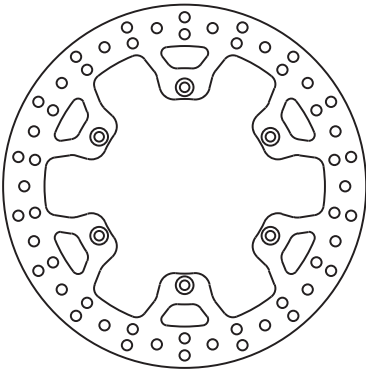
MST 317

A	B	C	D	E
267	118	4		134

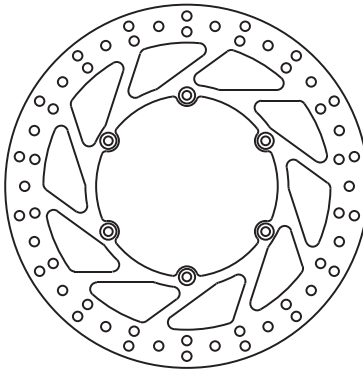
MST 318

A	B	C	D	E
220	100	3		120

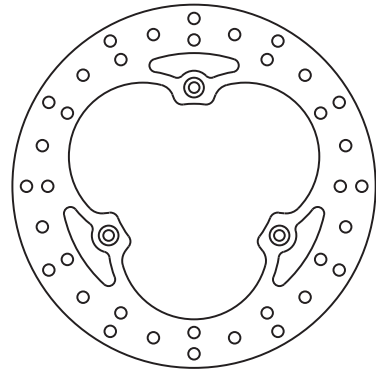
MST 318 EC

A	B	C	D	E
220	100	3		120

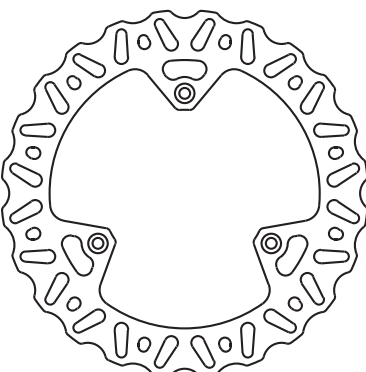
MST 319

A	B	C	D	E
260	120	3		135

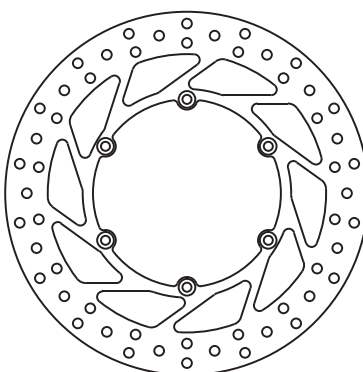
MST 320

A	B	C	D	E
260	120	3		135

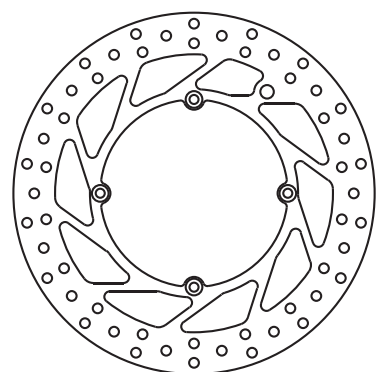



MST 320 EC

A	B	C	D	E
260	120	3		135

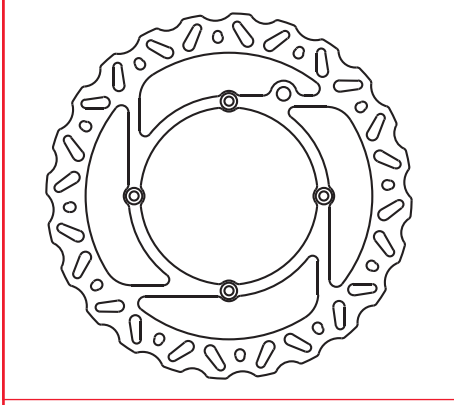

MST 321

A	B	C	D	E
220	121	4		140

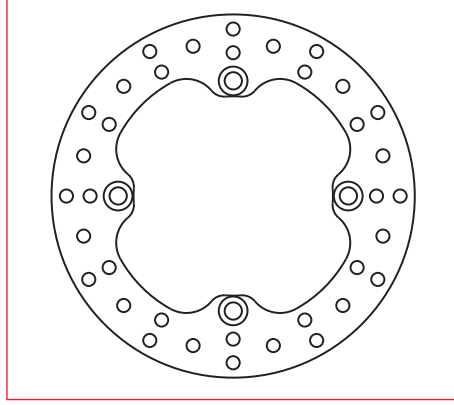

MST 322

A	B	C	D	E
240	121	4		140

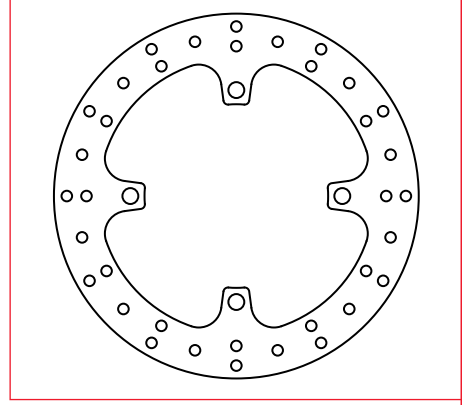

MST 323

A	B	C	D	E
220	105	4		125

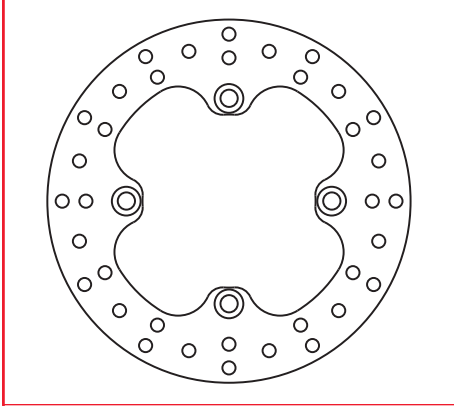

MST 324

A	B	C	D	E
190	80	3		94

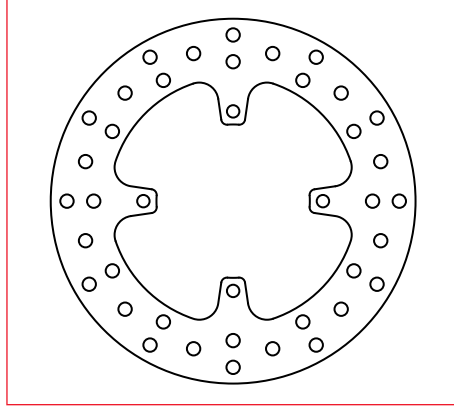

MST 324 EC

A	B	C	D	E
190	80	3		94

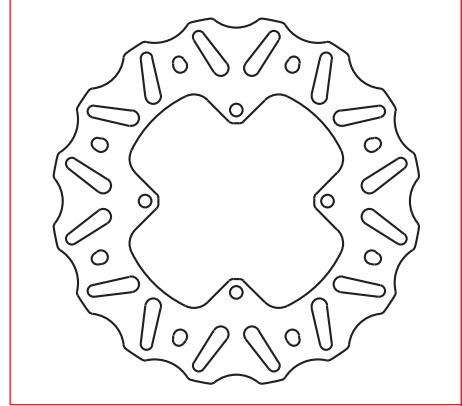

MST 325

A	B	C	D	E
256	144	4		166

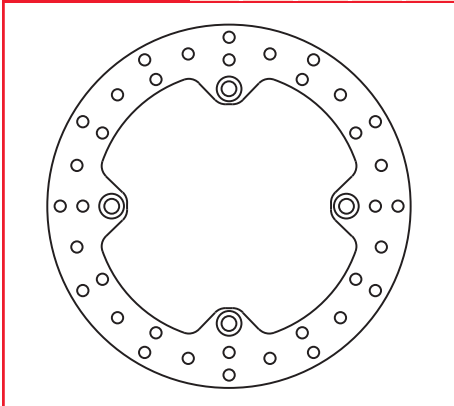

MST 326

A	B	C	D	E
220	105	5		125

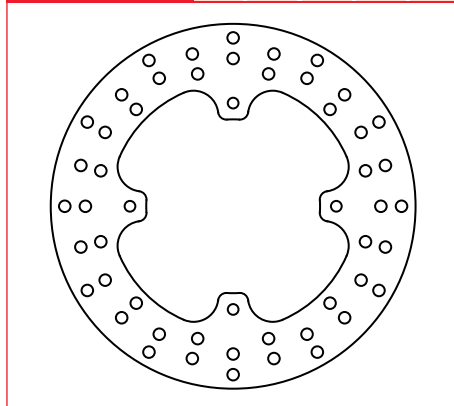

MST 328

A	B	C	D	E
240	121	4		140

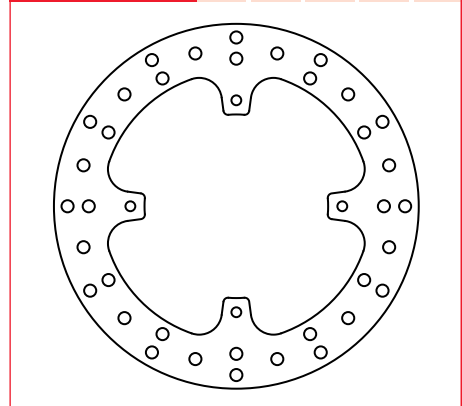

MST 328 EC

A	B	C	D	E
240	121	4		140

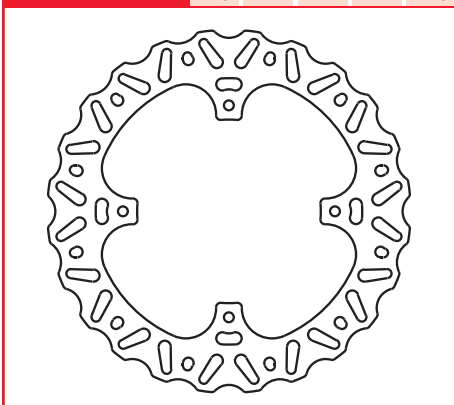

MST 328 RAC

A	B	C	D	E
240	121	4		140

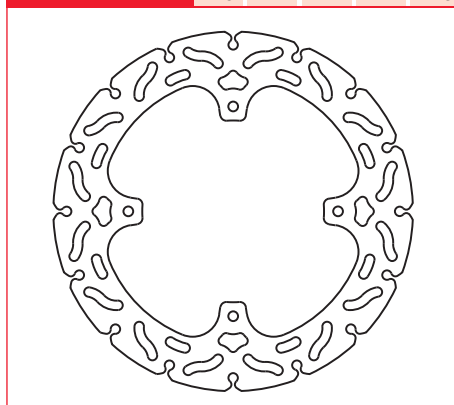

MST 330

A	B	C	D	E
240	110	5		124

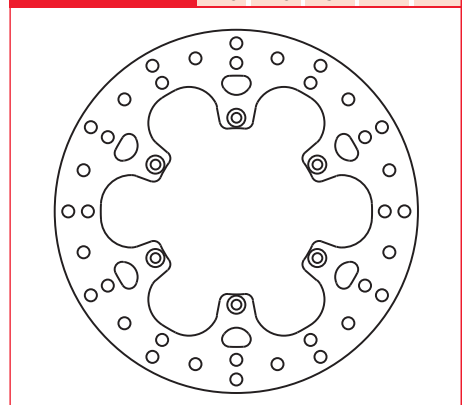



MST 331

A	B	C	D	E
276	174	5		198

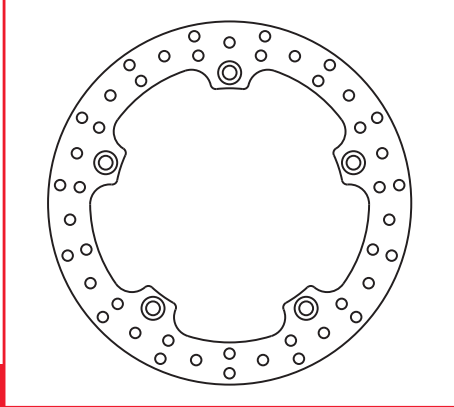

MST 331 RAC

A	B	C	D	E
276	174	5		198

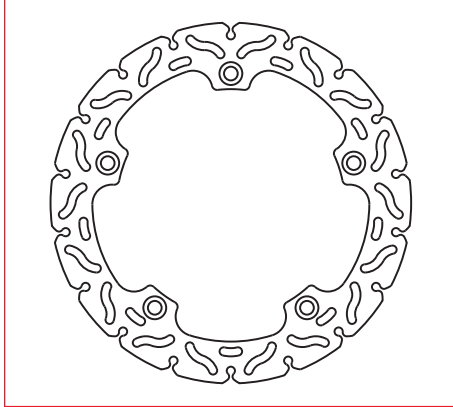

MST 332

A	B	C	D	E
184	84	3		100

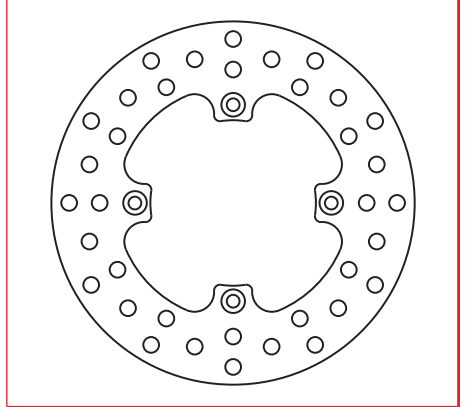

MST 333

A	B	C	D	E
220	100	4		116

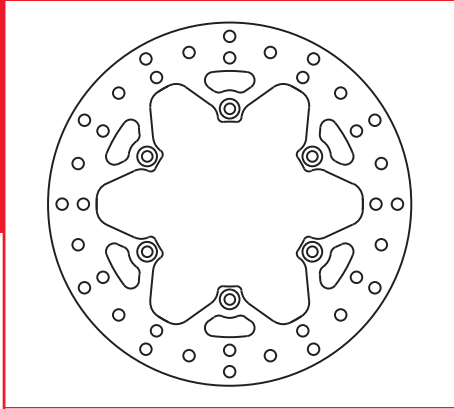

MST 335

A	B	C	D	E
220	100	4		116

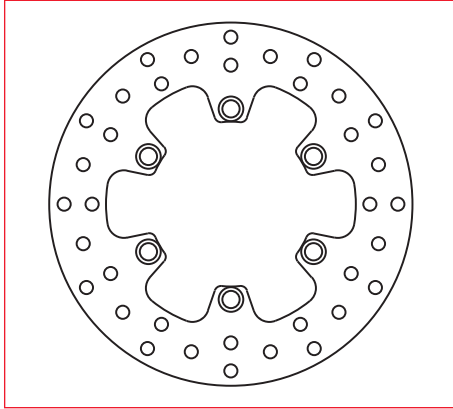

MST 336

A	B	C	D	E
230	100	4		116

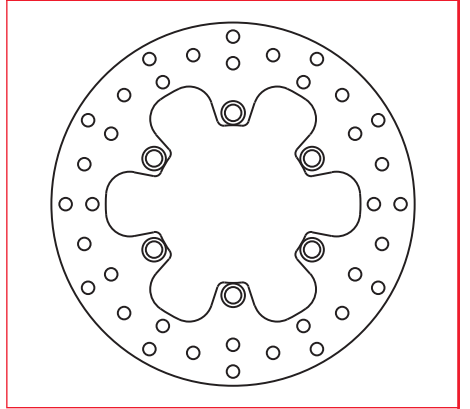

MST 337

A	B	C	D	E
298	105	5		120

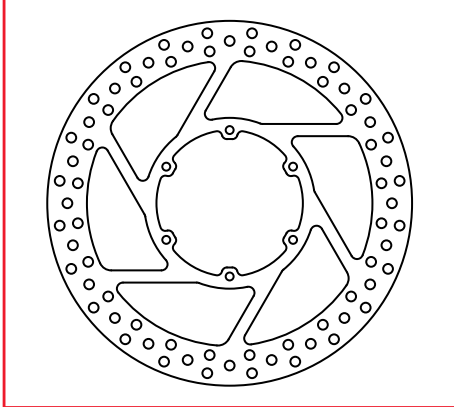

MST 337 RAC

A	B	C	D	E
298	105	5		120

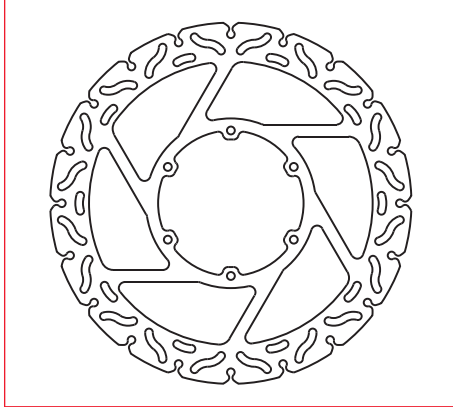

MST 338

A	B	C	D	E
240	116	5		136

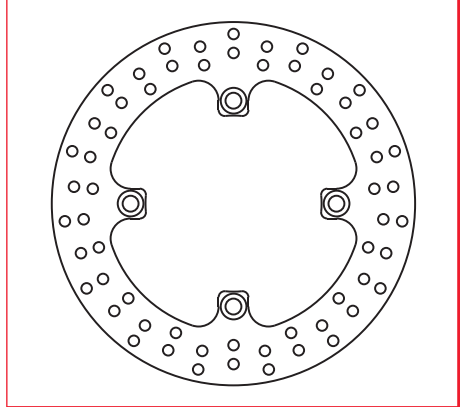

MST 338 RAC

A	B	C	D	E
240	116	5		136

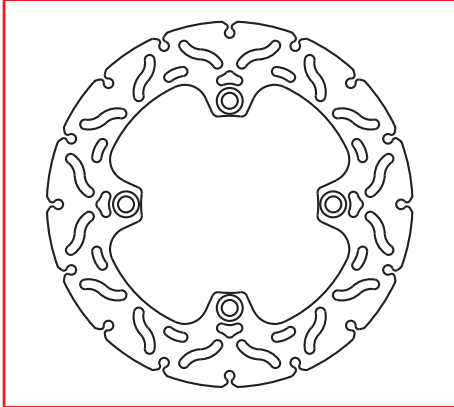

MST 339

A	B	C	D	E
240	115	4		133

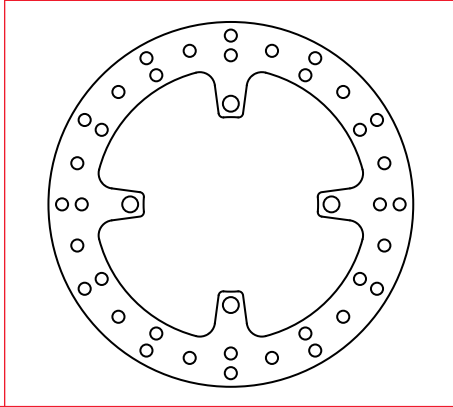

MST 339 EC

A	B	C	D	E
240	115	4		133

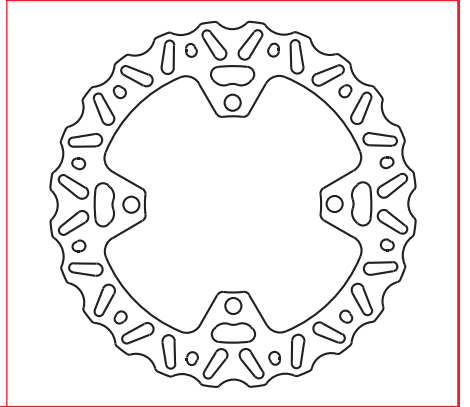



MST 339 RAC

A	B	C	D	E
240	115	4		133

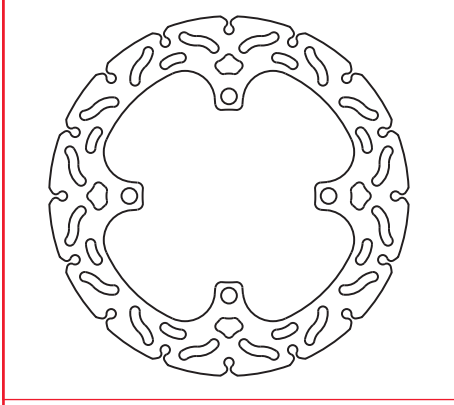

MST 340

A	B	C	D	E
220	83,5	4		104

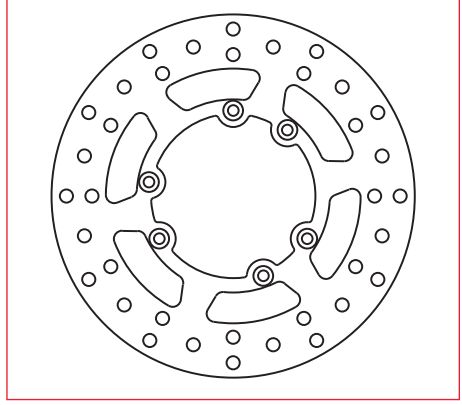

MST 341

A	B	C	D	E
220	118	4		134

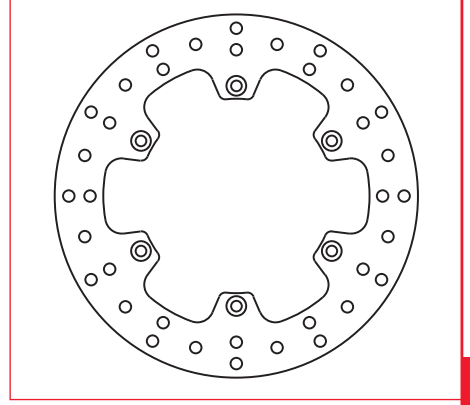

MST 341 RAC

A	B	C	D	E
220	118	4		134

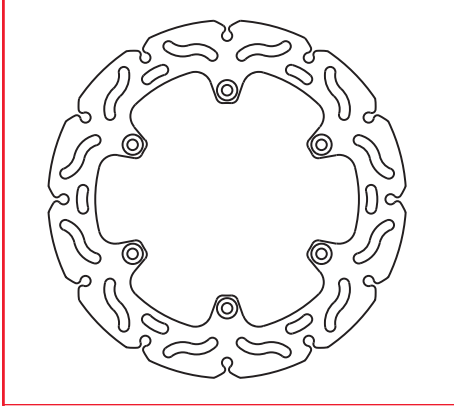

MST 342

A	B	C	D	E
240	118	4		134

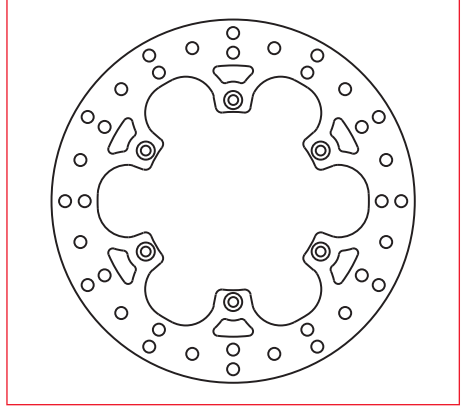

MST 342 RAC

A	B	C	D	E
240	118	4		134

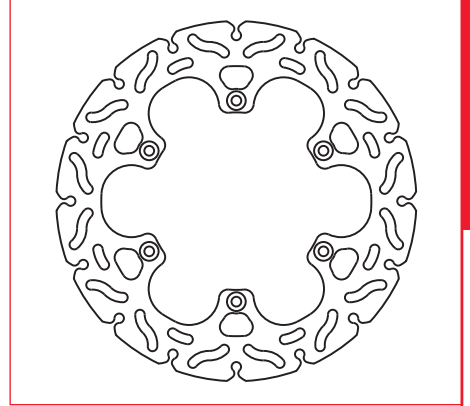

MST 343 RAC

A	B	C	D	E
260	140	5		161

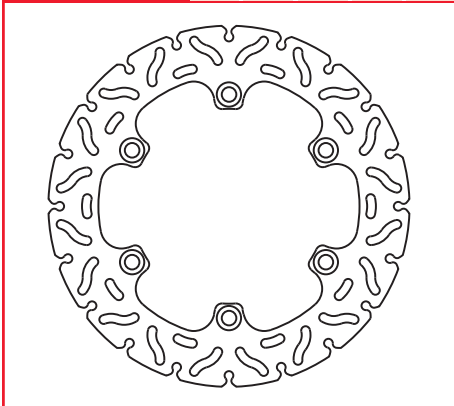

MST 346

A	B	C	D	E
220	115	4		133

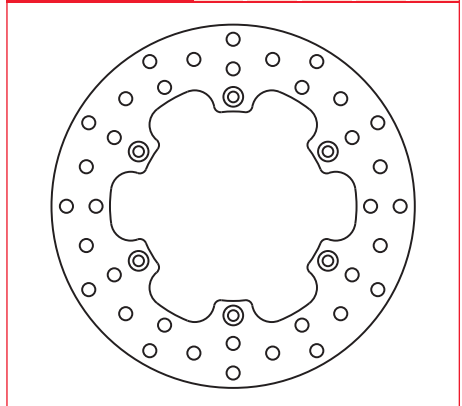

MST 347

A	B	C	D	E
240	115	4		133

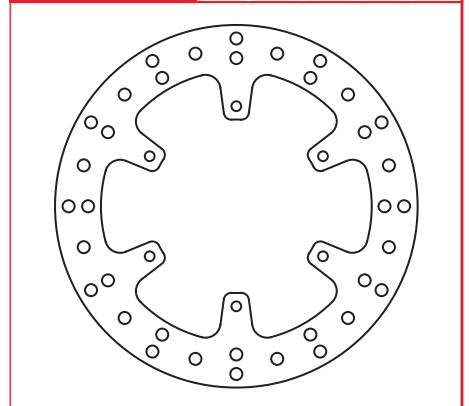

MST 348

A	B	C	D	E
190	84	3		100

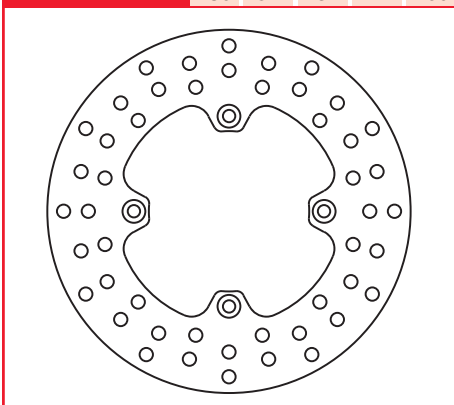

MST 348 EC

A	B	C	D	E
190	84	3		100

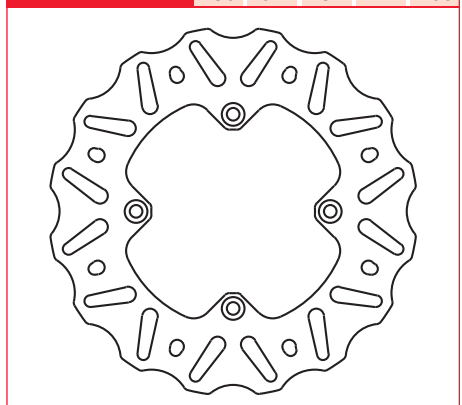

MST 349

A	B	C	D	E
220	86	5		102

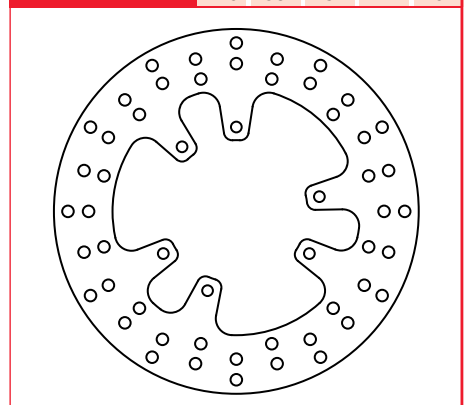

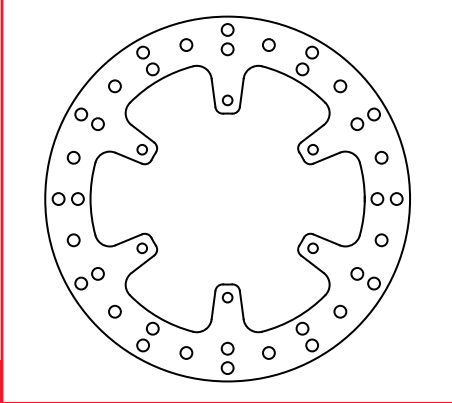

MST 350

A	B	C	D	E
245	115	4		133

MST 350 EC

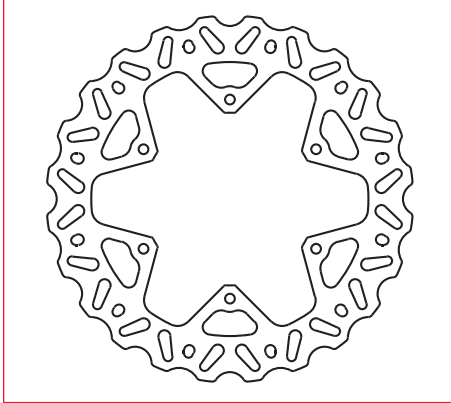
A	B	C	D	E
245	115	4		133

MST 350 RAC

A	B	C	D	E
245	115	4		133

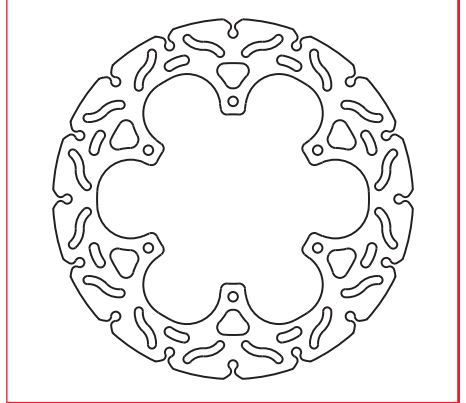
MST 351

A	B	C	D	E
220	112	4		130

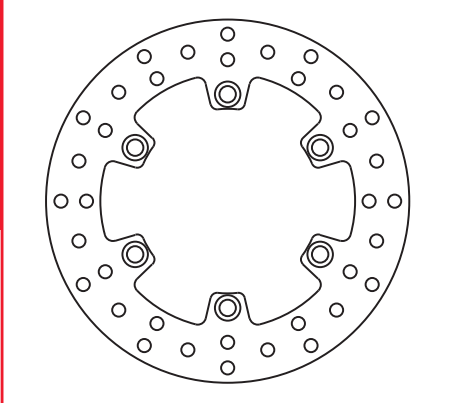
MST 353

A	B	C	D	E
220	112	4		130

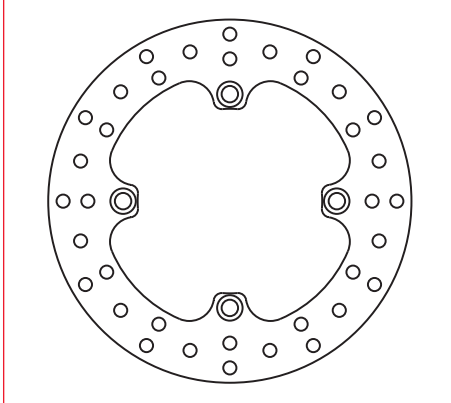
MST 355

A	B	C	D	E
230	86	3		100

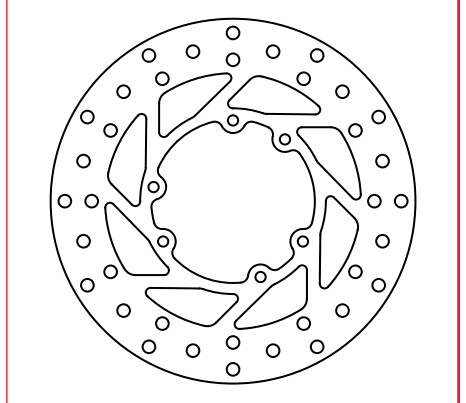
MST 356

A	B	C	D	E
320	181	4,5		202,5

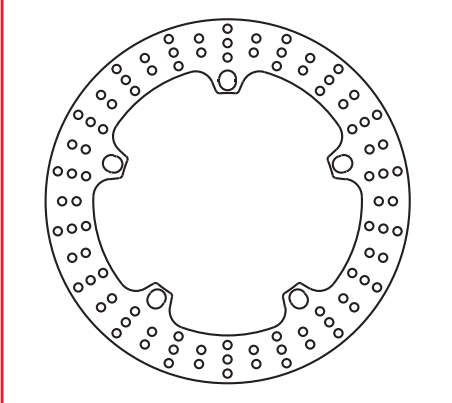
MST 356 RAC

A	B	C	D	E
320	181	4,5		202,5

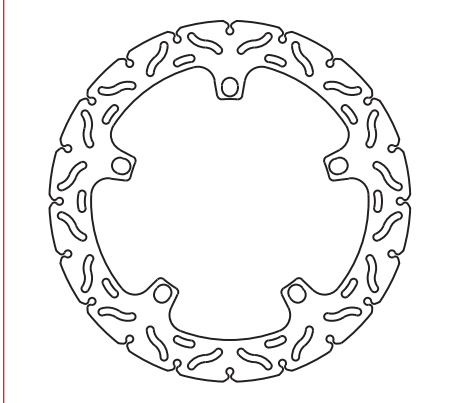
MST 357

A	B	C	D	E
320	181	5		202,5

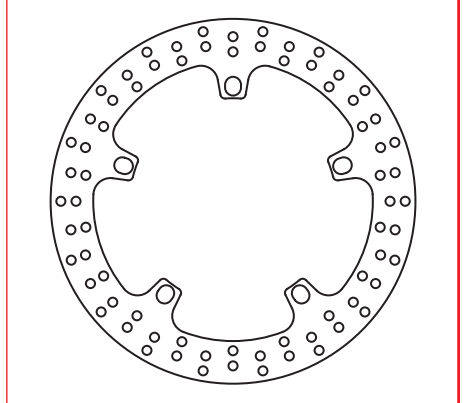
MST 357 FS

A	B	C	D	E
320	181	5		203

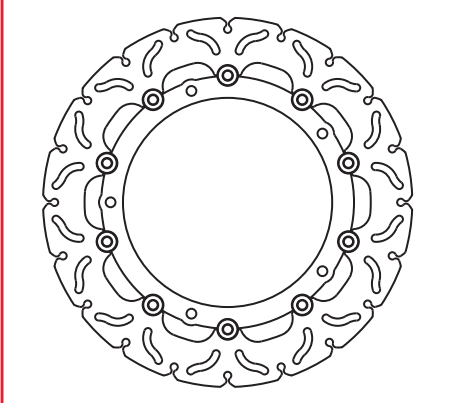
MST 357 RAC

A	B	C	D	E
320	181	5		202,5

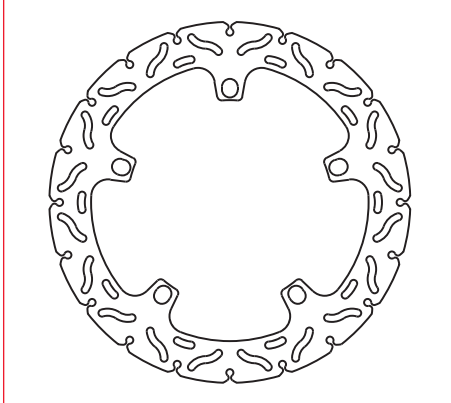
MST 362

A	B	C	D	E
220	106	5		125

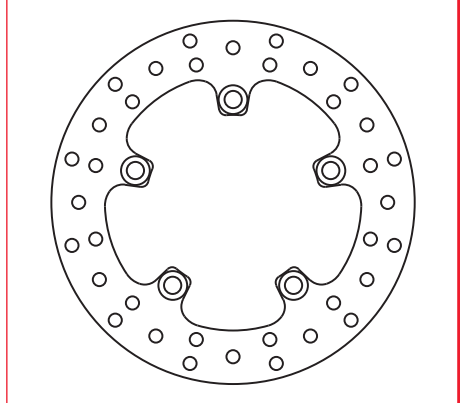



MST 362 RAC

A	B	C	D	E
220	106	5		125

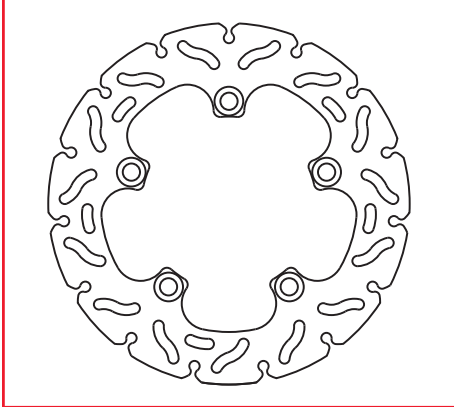

MST 362 SL

A	B	C	D	E
220	106	4		125

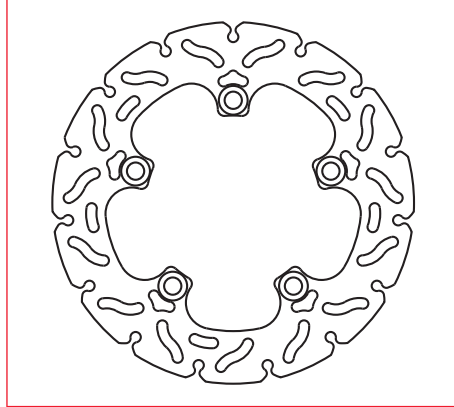

MST 363

A	B	C	D	E
220	116	5		133

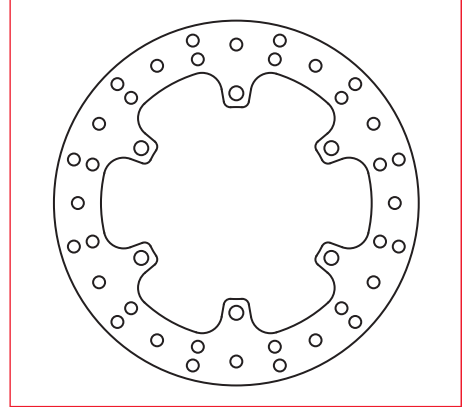

MST 364

A	B	C	D	E
250	84	5		100

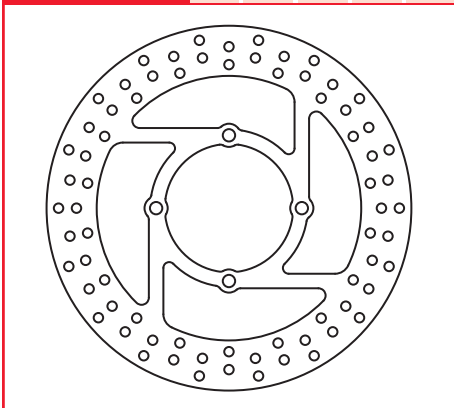

MST 365

A	B	C	D	E
275	57	5		78

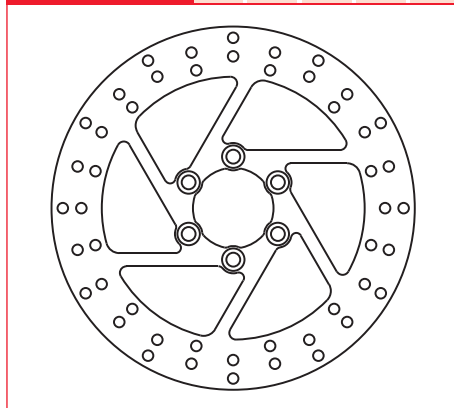

MST 366

A	B	C	D	E
220	100	5		120

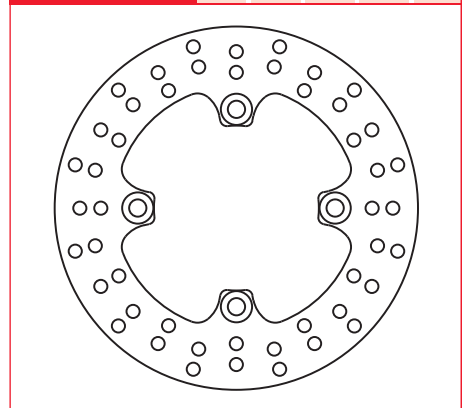

MST 366 RAC

A	B	C	D	E
220	100	5		120

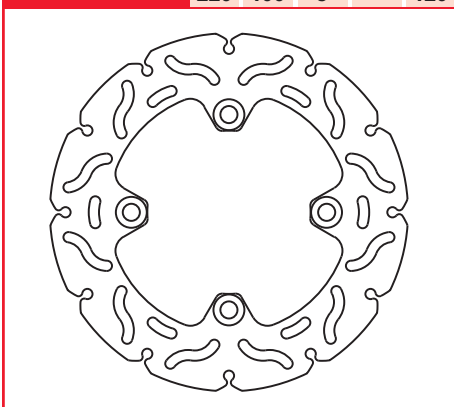

MST 366 SL

A	B	C	D	E
220	100	4		120

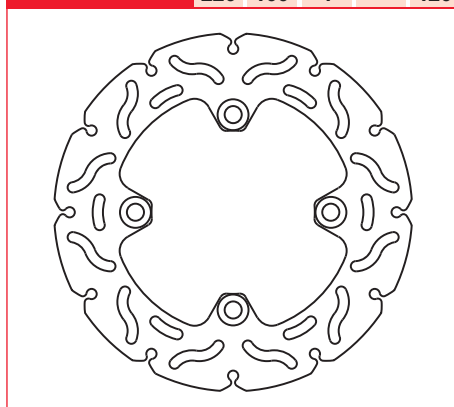

MST 367

A	B	C	D	E
230	83	4		104

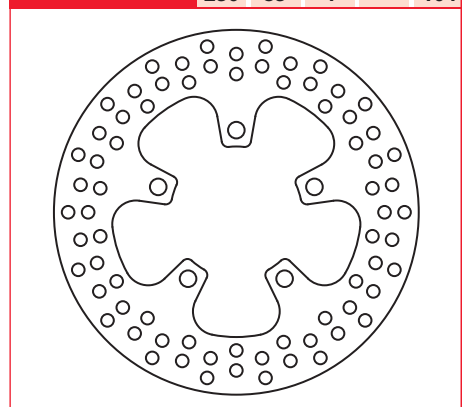

MST 368

A	B	C	D	E
260	141	5		162

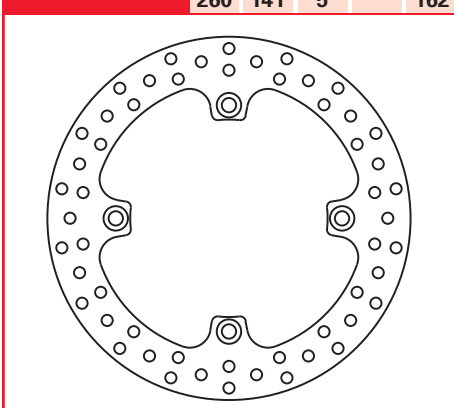

MST 369

A	B	C	D	E
245	115	4		133

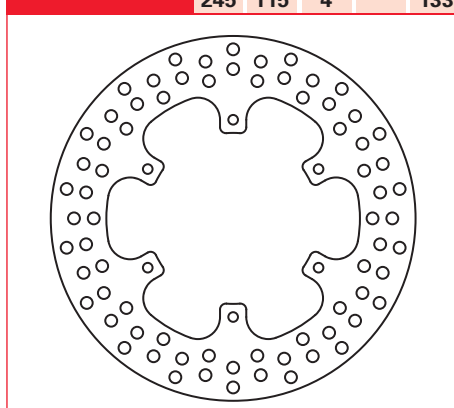

MST 370

A	B	C	D	E
245	80	4		98

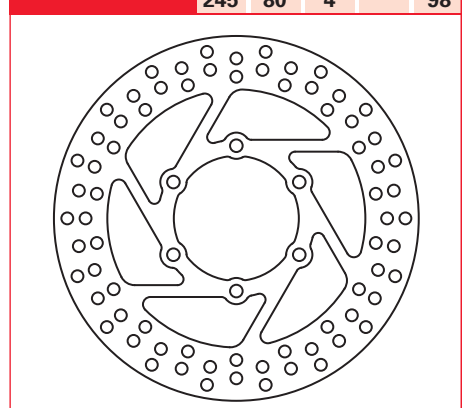

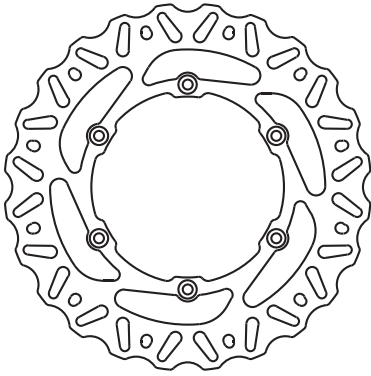

MST 371EC

A	B	C	D	E
240	118	4		134

MST 371 RAC

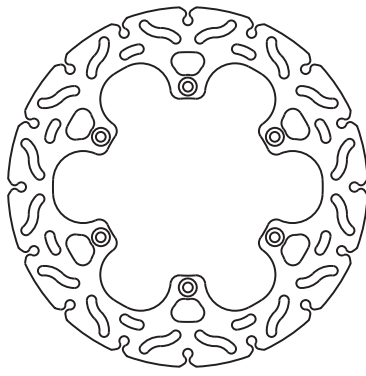
A	B	C	D	E
240	118	4		134

MST 372

A	B	C	D	E
265	136,5	5		160

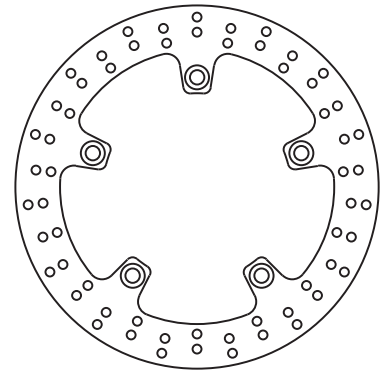
MST 372 RAC

A	B	C	D	E
265	136,5	5		160

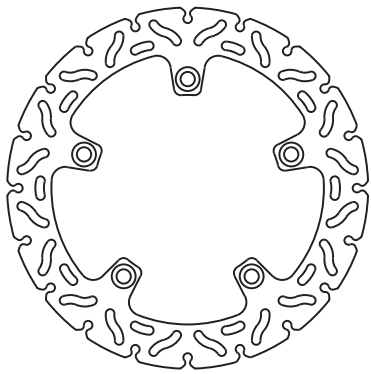
MST 373

A	B	C	D	E
256	145	5		166

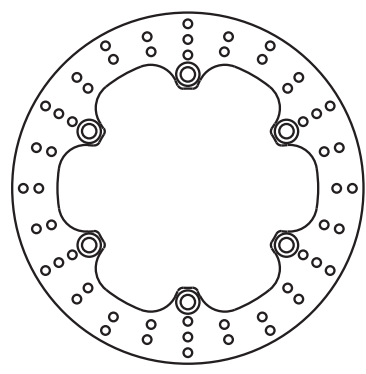
MST 373 RAC

A	B	C	D	E
256	145	5		166

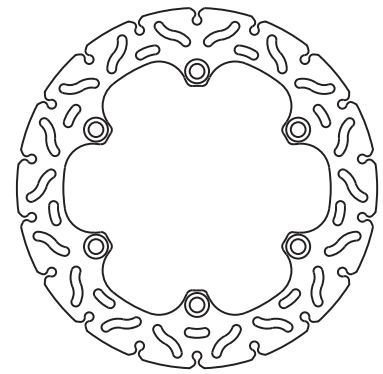
MST 374

A	B	C	D	E
245	105	5		125

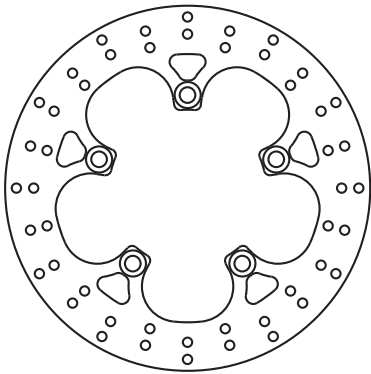
MST 374 RAC

A	B	C	D	E
245	105	5		125

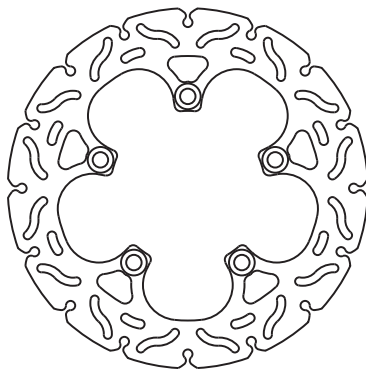
MST 375 RAC

A	B	C	D	E
250	110	5		130

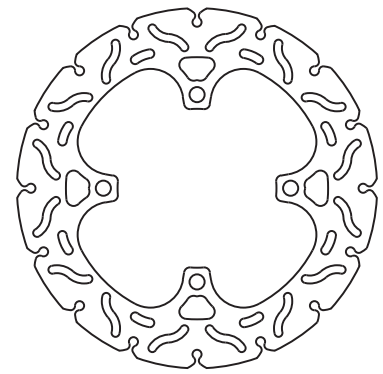
MST 376 RAC

A	B	C	D	E
220	102,8	5		120

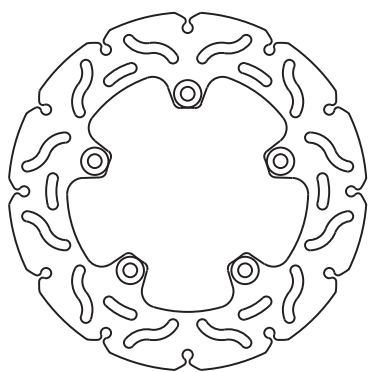
MST 377 RAC

A	B	C	D	E
245	108	5		125

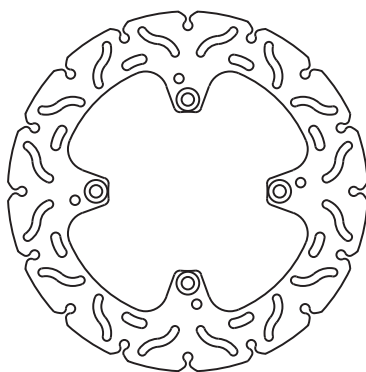
MST 378 RAC

A	B	C	D	E
240	107,5	5		130

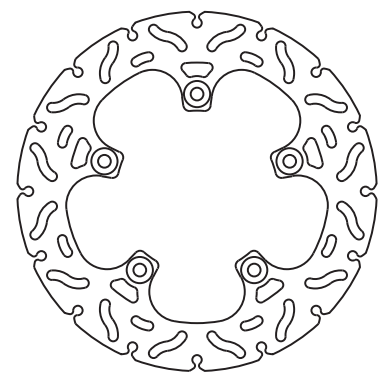



MST 379

A	B	C	D	E
300	126,5	4		143

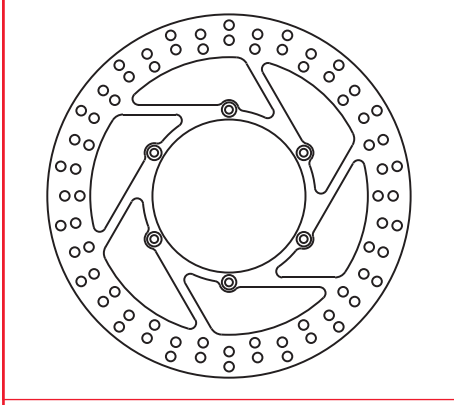

MST 380

A	B	C	D	E
260	121,5	5		142

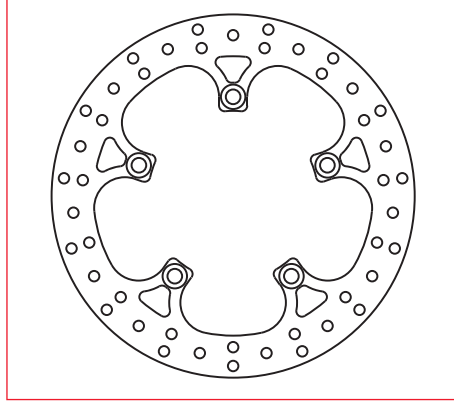

MST 381

A	B	C	D	E
210	90	5		110

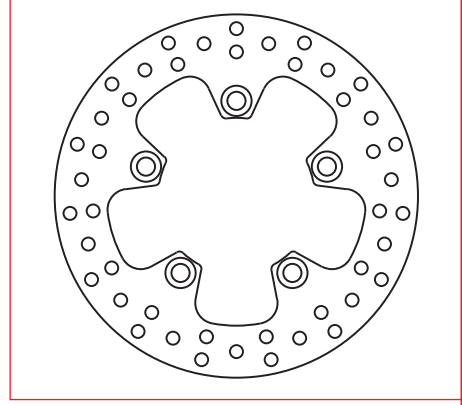

MST 382

A	B	C	D	E
240	92,5	5		114

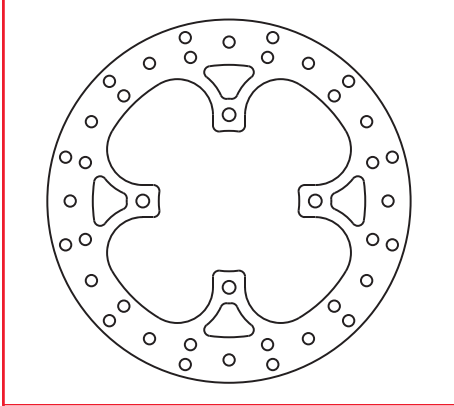

MST 383

A	B	C	D	E
292	155	4		170

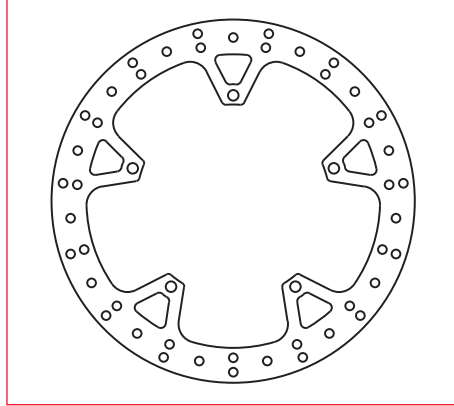

MST 384

A	B	C	D	E
180	63,5	4		82,5

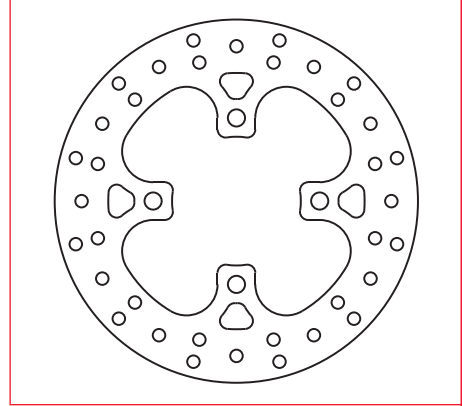

MST 385

A	B	C	D	E
200	76	4		102

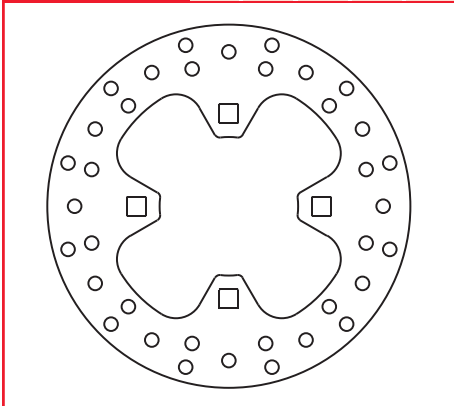

MST 386

A	B	C	D	E
240	120,5	5		141

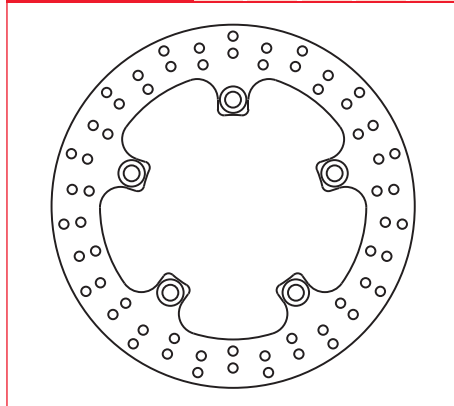

MST 386 RAC

A	B	C	D	E
240	120,5	5		141

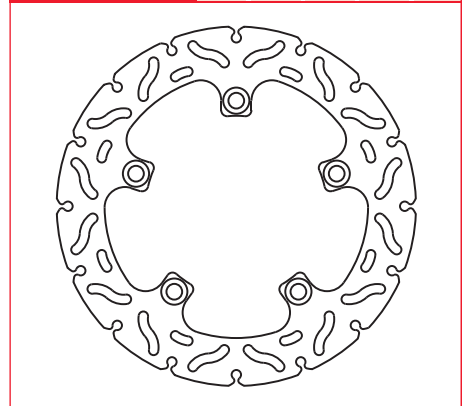

MST 387

A	B	C	D	E
298	105	4		120

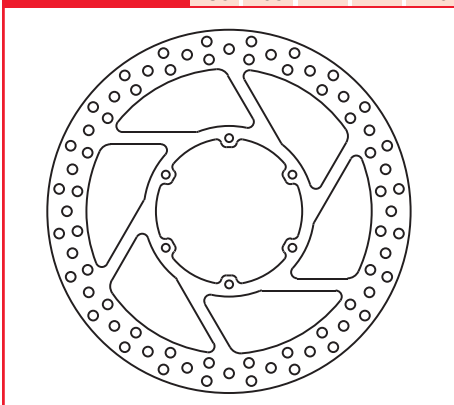

MST 388 RAC

A	B	C	D	E
230	115	4		133

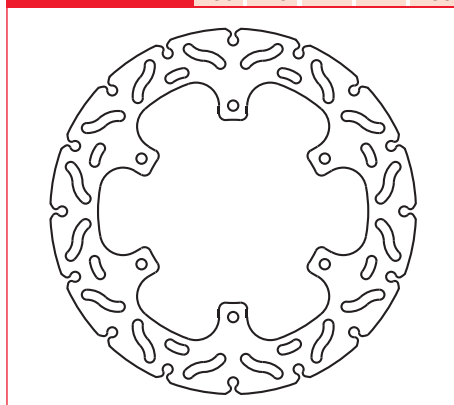

MST 389

A	B	C	D	E
230	102	4		120

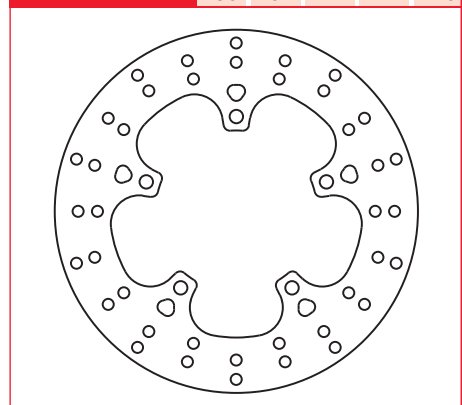

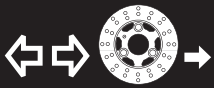

MST 390 RAC

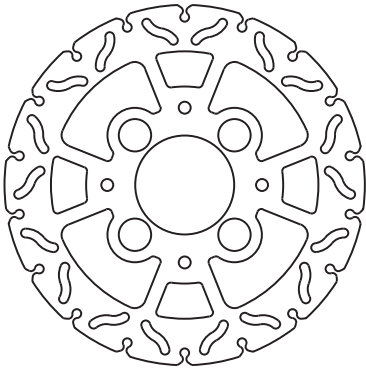
A	B	C	D	E
256	70	5		110

MST 391

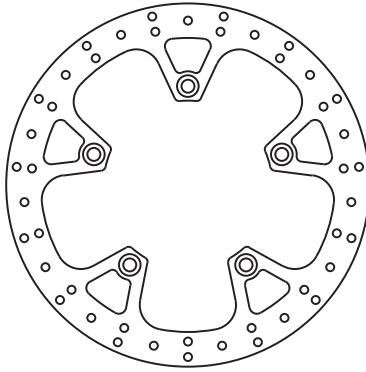
A	B	C	D	E
294	136,5	5		160

MST 392

A	B	C	D	E
220	119	5		136

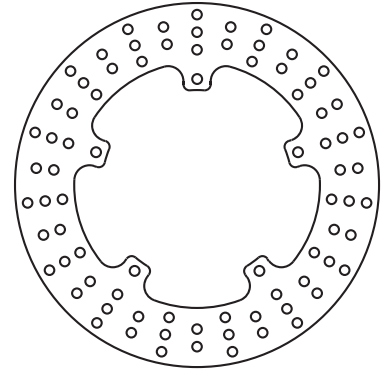
MST 392 RAC

A	B	C	D	E
220	119	5		136

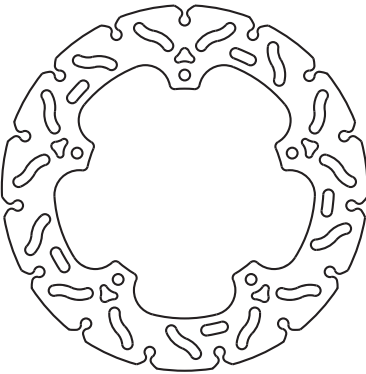
MST 393

A	B	C	D	E
256	94,3	5		110

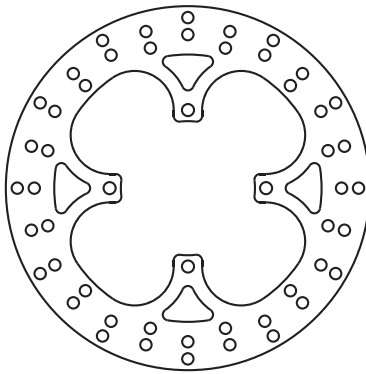
MST 394

A	B	C	D	E
240	105	4		120

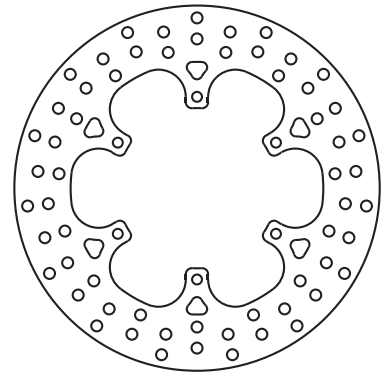
MST 395

A	B	C	D	E
240	125	5		140

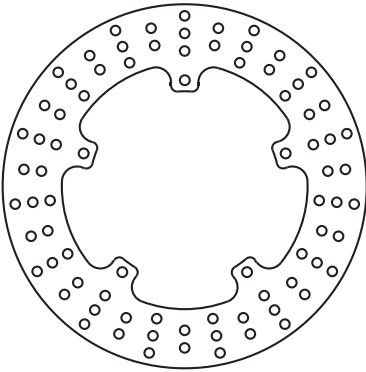
MST 396

A	B	C	D	E
220	105,3	4		120

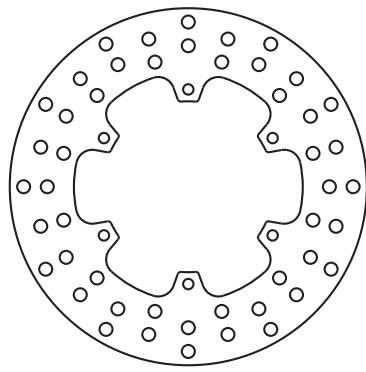
MST 397 RAC

A	B	C	D	E
220	100	5		120

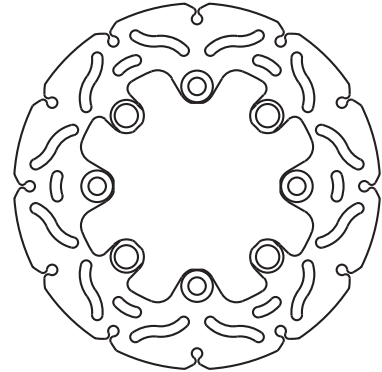
MST 398

A	B	C	D	E
256	94	5		110

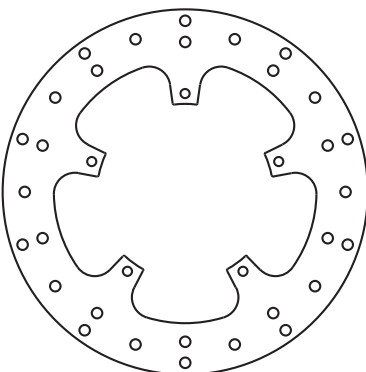
MST 399

A	B	C	D	E
240	126	4		130

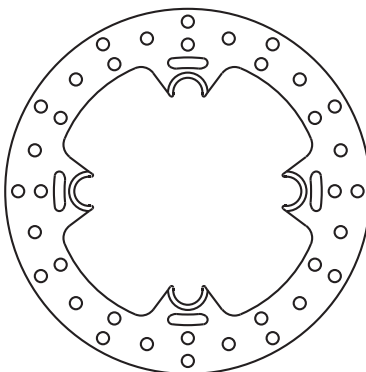
MST 400

A	B	C	D	E
165	48	4		66

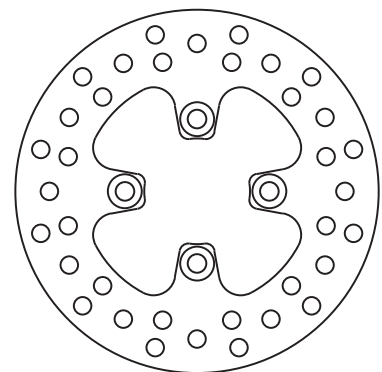



MST 401

A	B	C	D	E
196	81	4		100

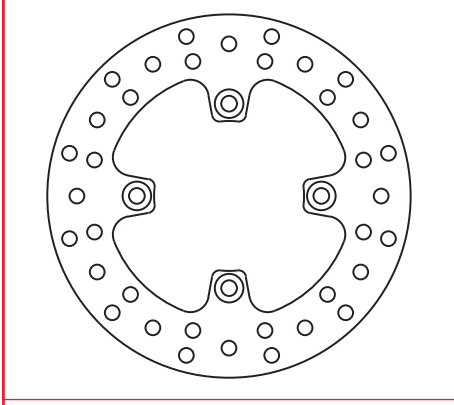

MST 402

A	B	C	D	E
170	48,5	3		68

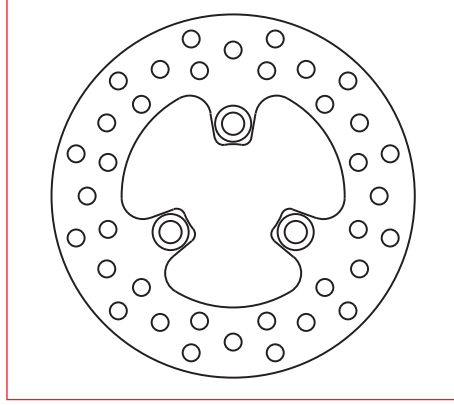

MST 403

A	B	C	D	E
174	53	3		72

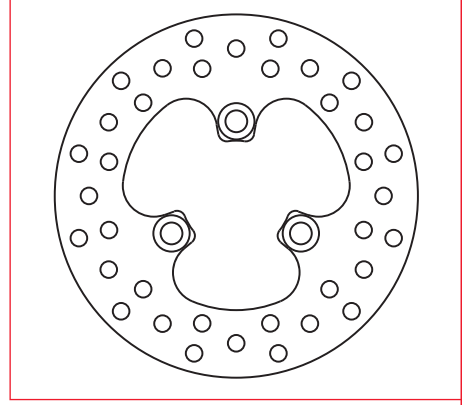

MST 404

A	B	C	D	E
220	58	4		80

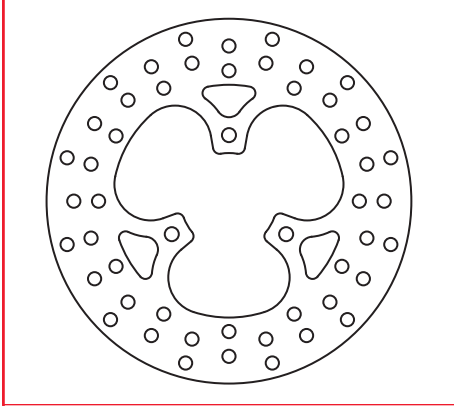

MST 405

A	B	C	D	E
161	48	4		66

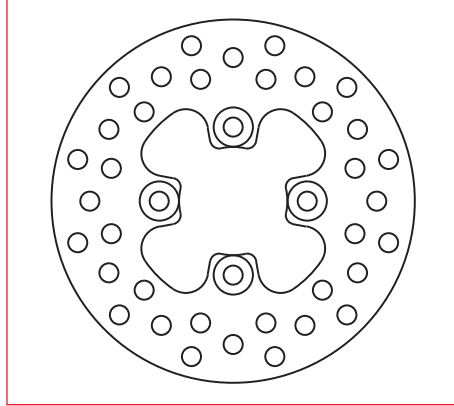

MST 406

A	B	C	D	E
245	58	4		76

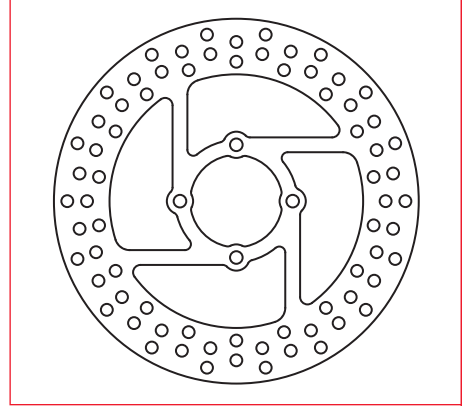

MST 407

A	B	C	D	E
220	58	4		76

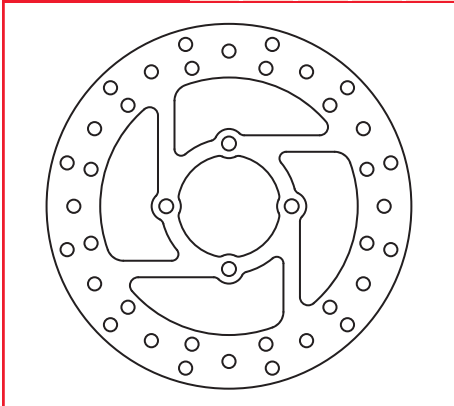

MST 408

A	B	C	D	E
163	51	3		72

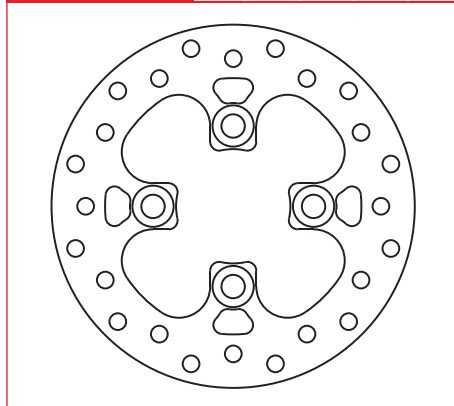

MST 409

A	B	C	D	E
260	60	4		80

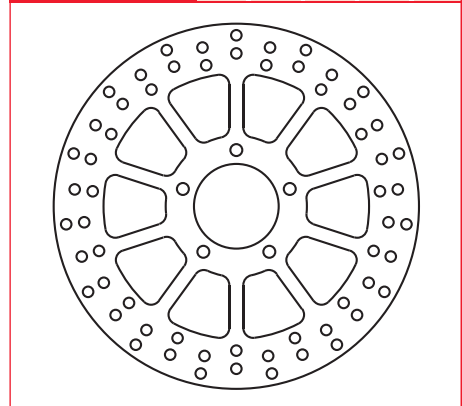

MST 410

A	B	C	D	E
200	51	4		71

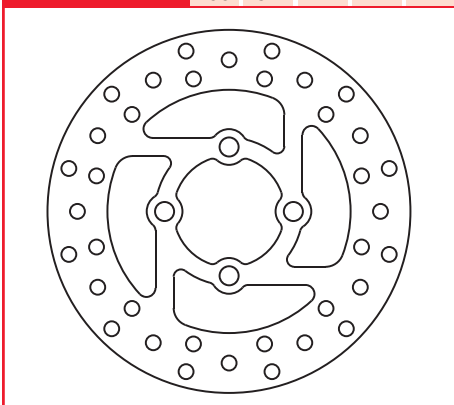

MST 411

A	B	C	D	E
160	48,5	3		68

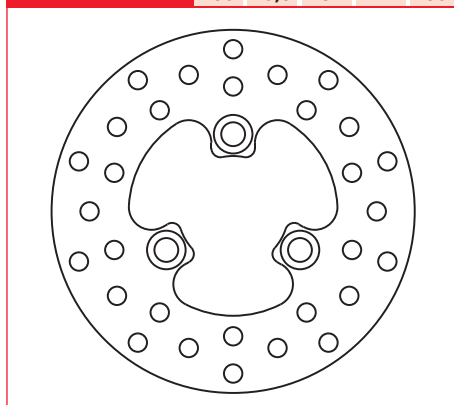

MST 412

A	B	C	D	E
190	78,5	4		98

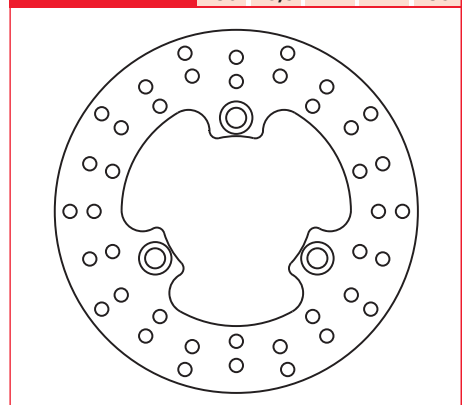



MST 413	A	B	C	D	E
	200	72	4		90

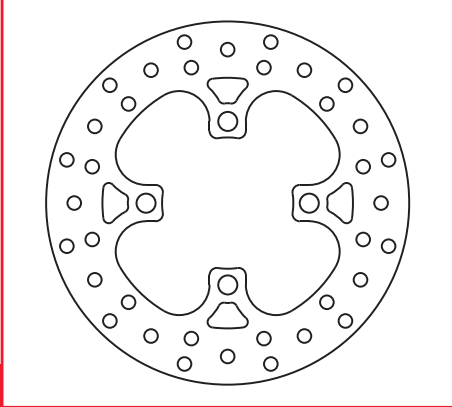

MST 414	A	B	C	D	E
	200	89,5	4		110

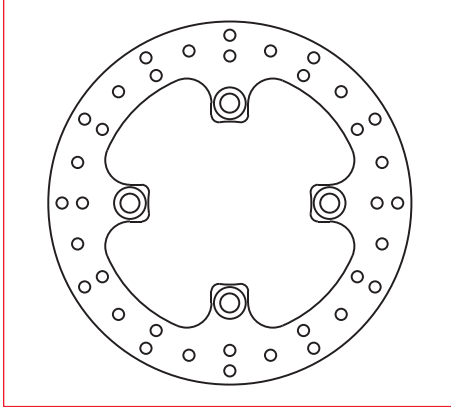

MST 415	A	B	C	D	E
	200	84	3		104

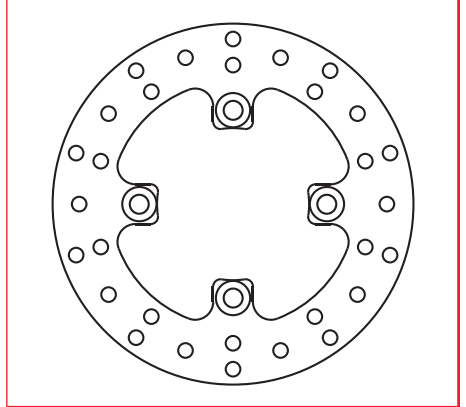

MST 416	A	B	C	D	E
	220	95,5	4		117

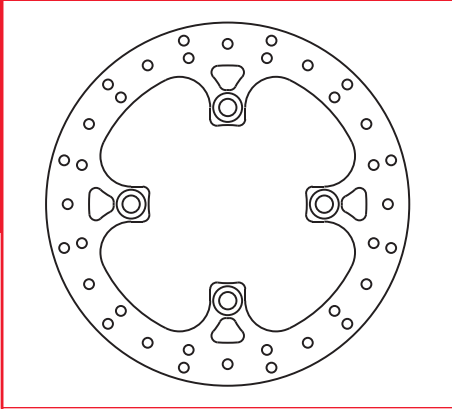

MST 417	A	B	C	D	E
	205	98	4		117

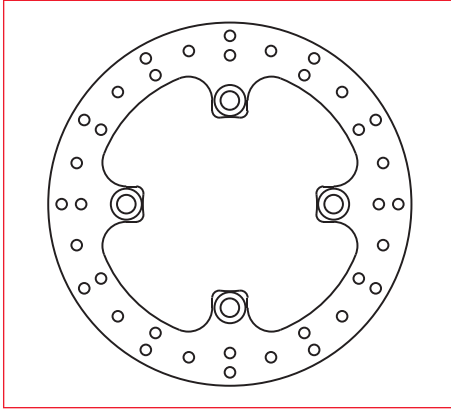

MST 418 RAC	A	B	C	D	E
	260	105	3		120

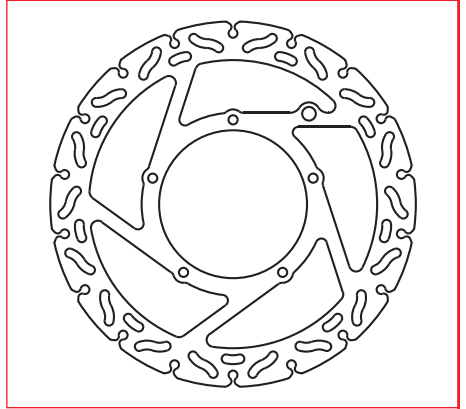

MST 419 RAC	A	B	C	D	E
	240	107	5		125

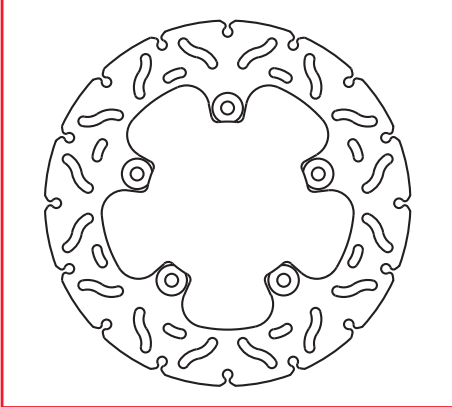

MST 420 RAC	A	B	C	D	E
	245	106	5		125

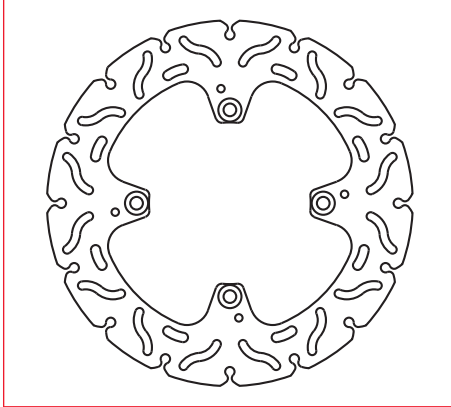

MST 421 RAC	A	B	C	D	E
	290	130	4,5		150

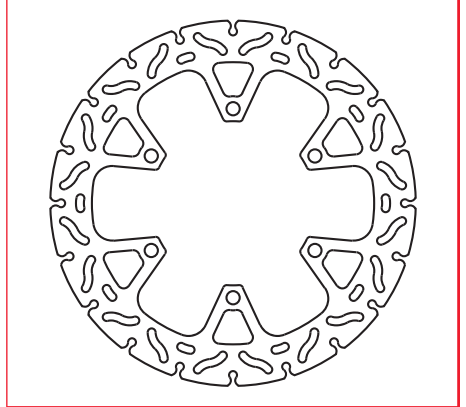

MST 422 RAC	A	B	C	D	E
	220	100	5		120

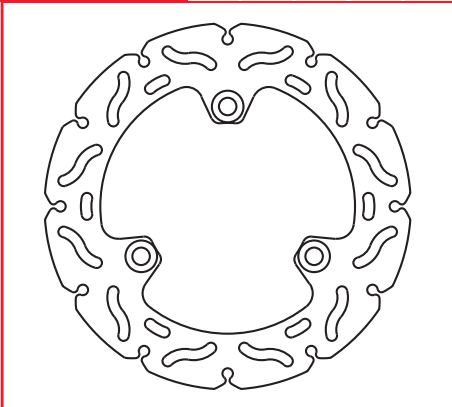

MST 423	A	B	C	D	E
	276	132	5		150

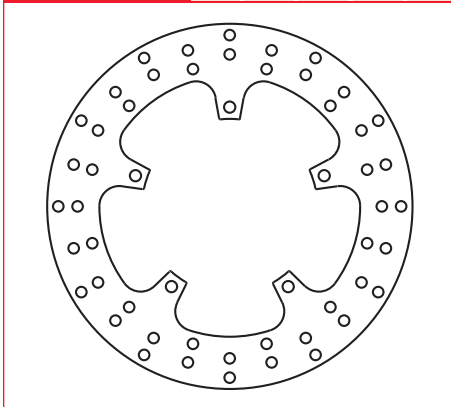

MST 424	A	B	C	D	E
	276	88	4		110

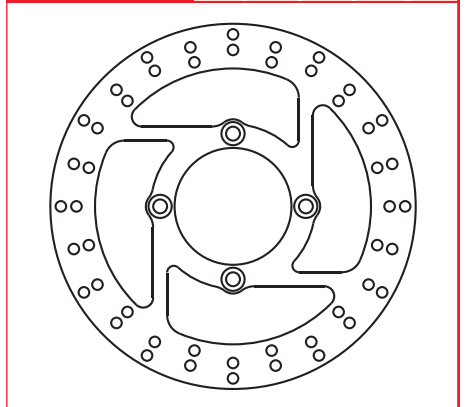



MST 425RAC

A	B	C	D	E
220	105	5		125

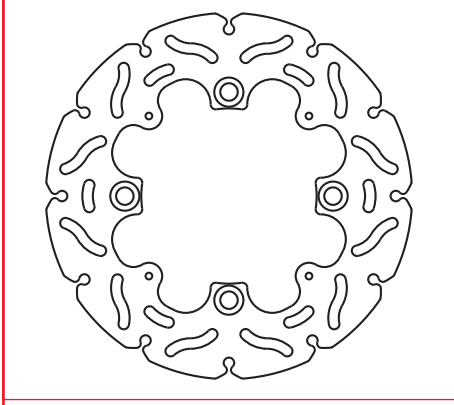

MST 426

A	B	C	D	E
256	70	5		110

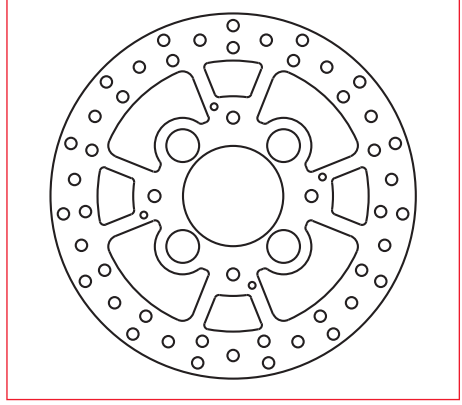

MST 427 RAC

A	B	C	D	E
220	105	5		125

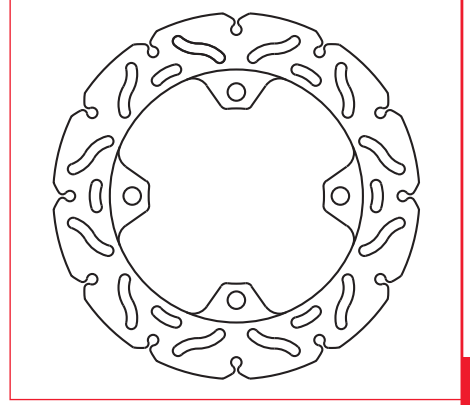

MST 428

A	B	C	D	E
316	184	6		205

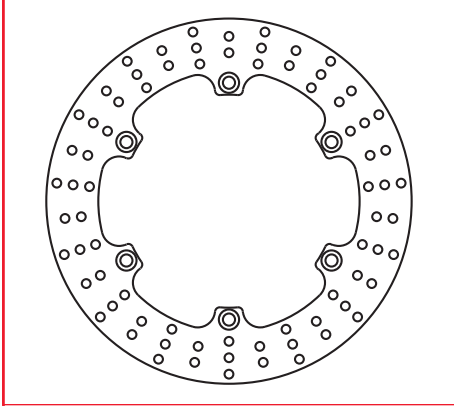

MST 429RAC

A	B	C	D	E
220	102	5		120

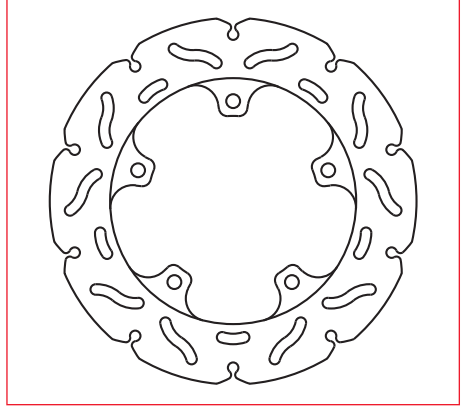

MST 430

A	B	C	D	E
240	102	5		120

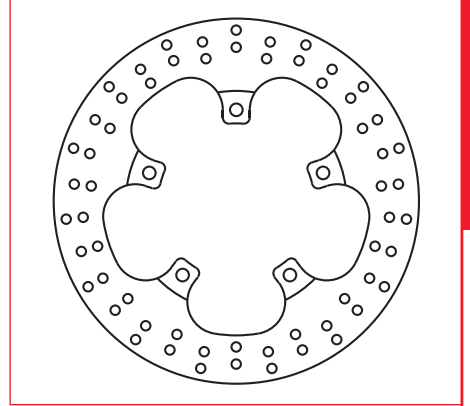

MST 431

A	B	C	D	E
260	100	5		120

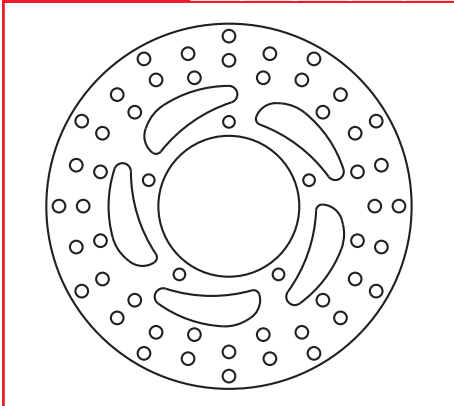

MST 432

A	B	C	D	E
282	132	5		150

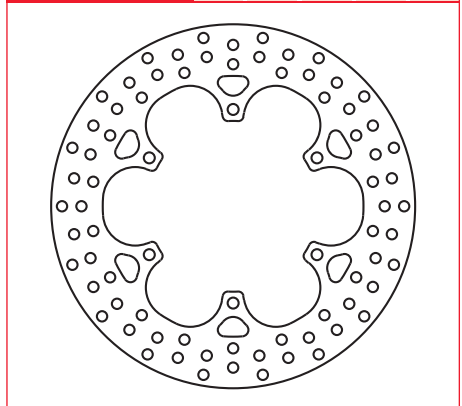

MST 433RAC

A	B	C	D	E
298	132	6		150

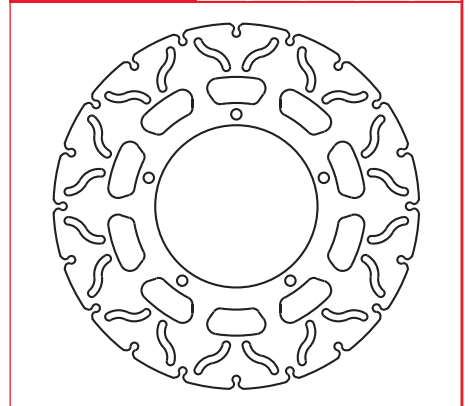

MST 434

A	B	C	D	E
255	105	6		125

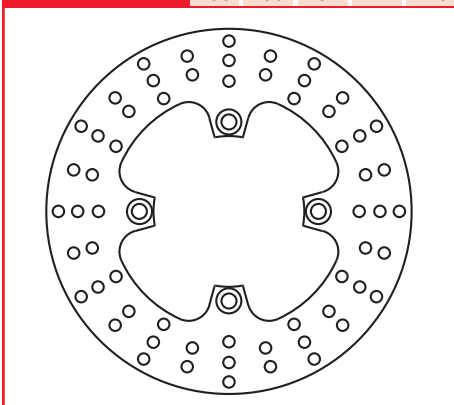

MST 436

A	B	C	D	E
220	105,3	5		125

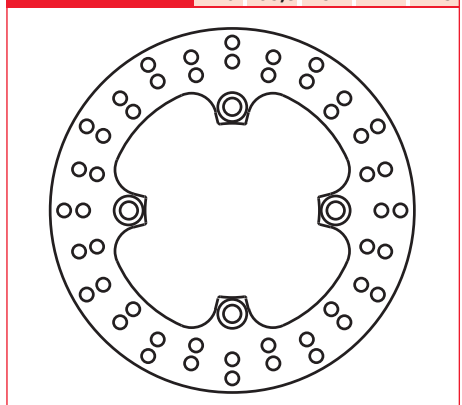

MST 437

A	B	C	D	E
240	90	5		110

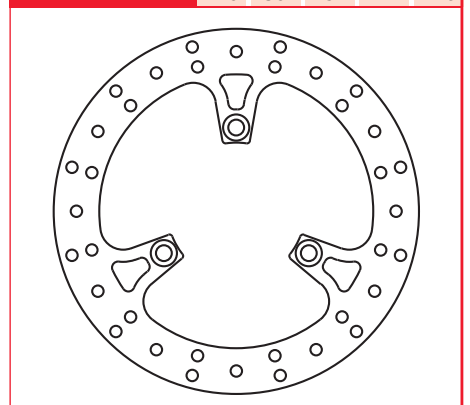

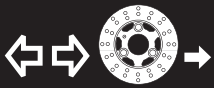

MST 438

A	B	C	D	E
240	110	5		125

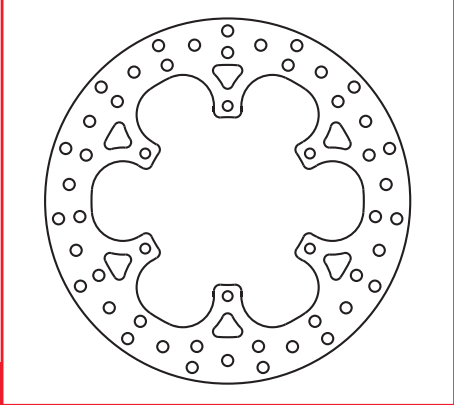

MST 439

A	B	C	D	E
240	110	5		125

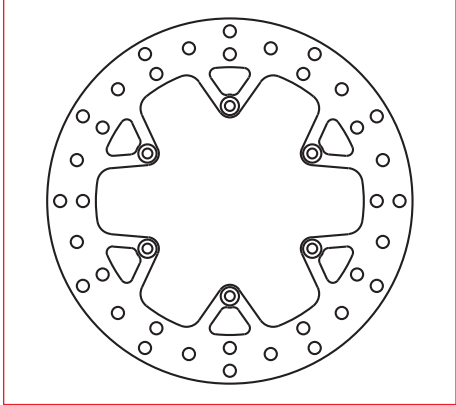

MST 440EC

A	B	C	D	E
240	112	4		130

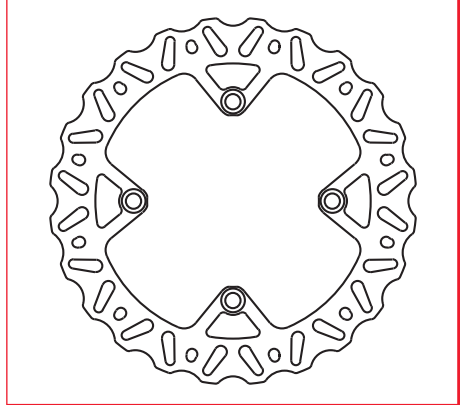

MST 441 EC

A	B	C	D	E
220	96	3		112

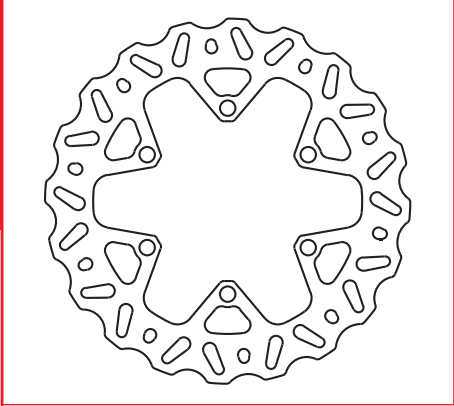

MST 442 EC

A	B	C	D	E
184	84	3		100

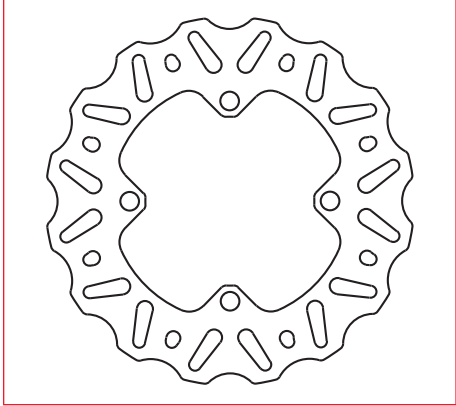

MST 443 EC

A	B	C	D	E
180	79	3		95

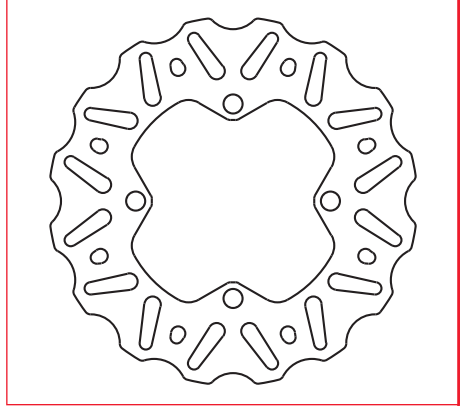

MST 444

A	B	C	D	E
255	105,3	5		125

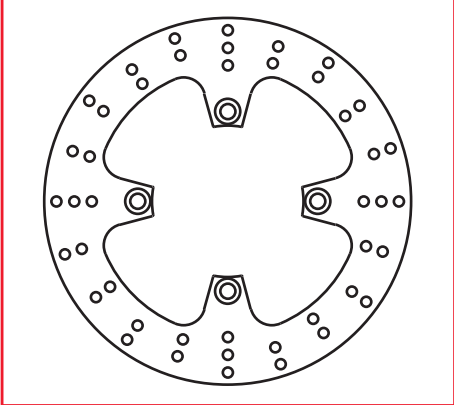

MST 445 RAC

A	B	C	D	E
220	100,3	5		120

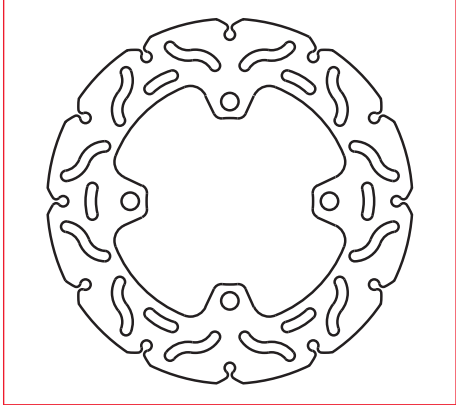

MST 446 RAC

A	B	C	D	E
240	117,3	5		136

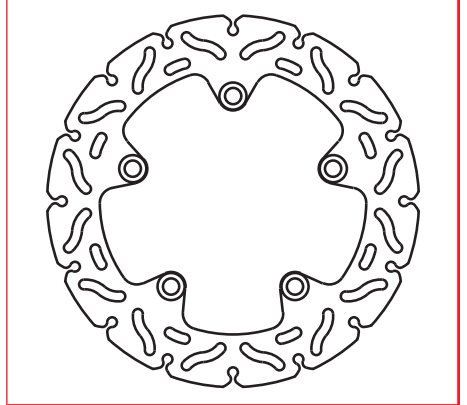

MST 447 RAC

A	B	C	D	E
320	210,3	5		230

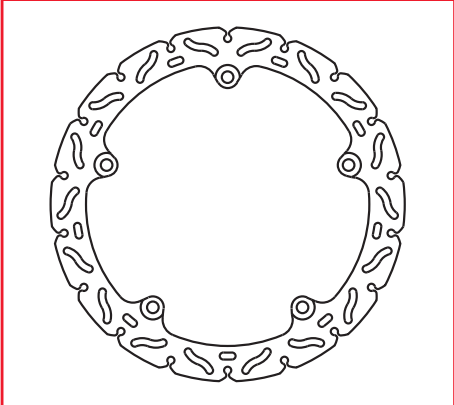

MST 448

A	B	C	D	E
276	170,3	5		190

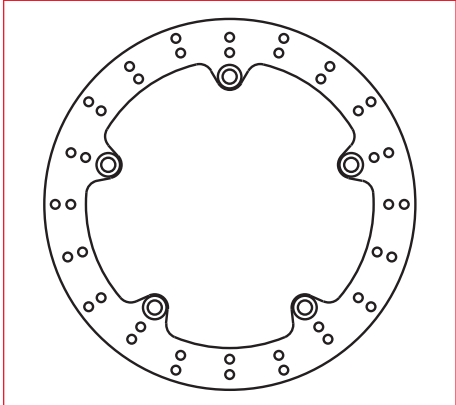

MST 449

A	B	C	D	E
310	165,3	4,5		195

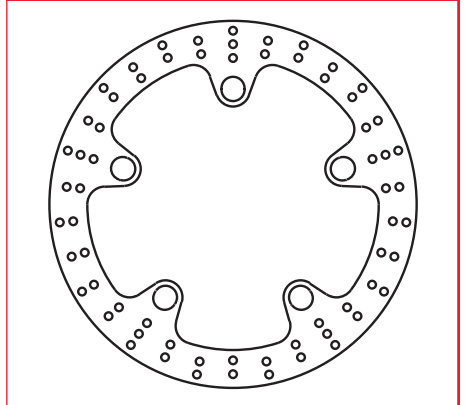



MST 450

A	B	C	D	E
256	144,3	4,5		166

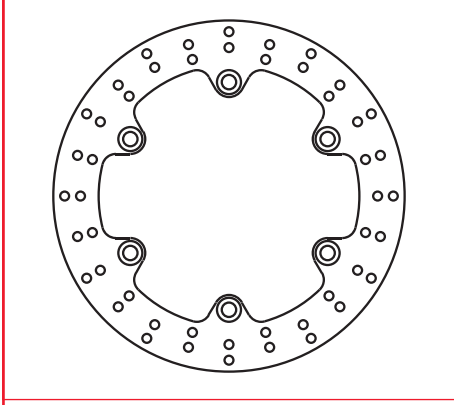

MST 452

A	B	C	D	E
220	58,3	3,5		78

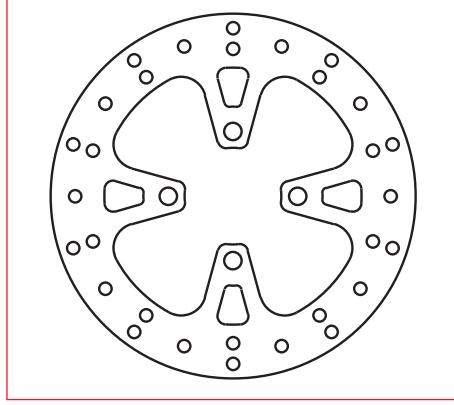

MST 453

A	B	C	D	E
240	105,3	4		125

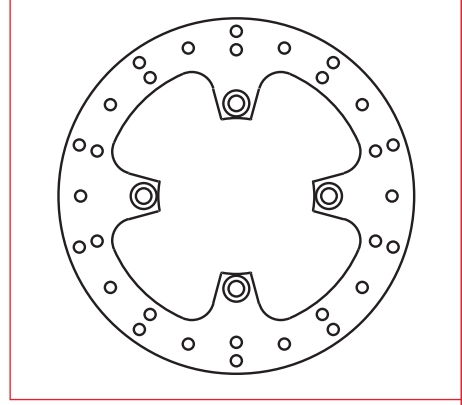

MST 454

A	B	C	D	E
256	101,3	3,1		117

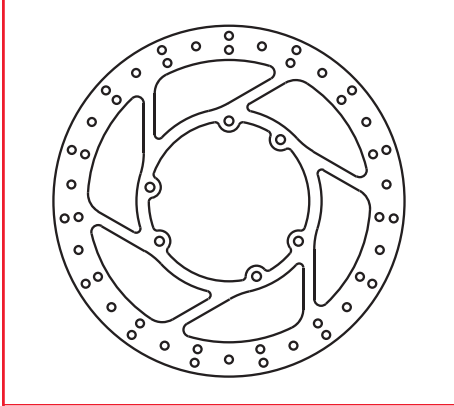

MST 455

A	B	C	D	E
220	105,3	5		125

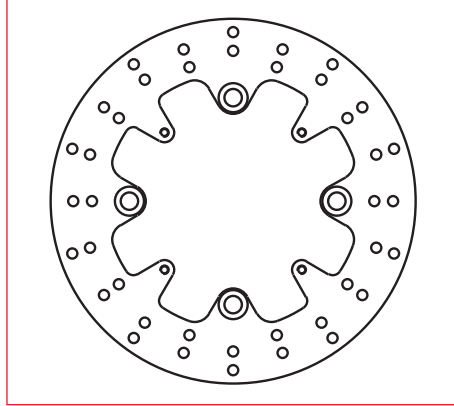

MST 456

A	B	C	D	E
270	150,3	5		175

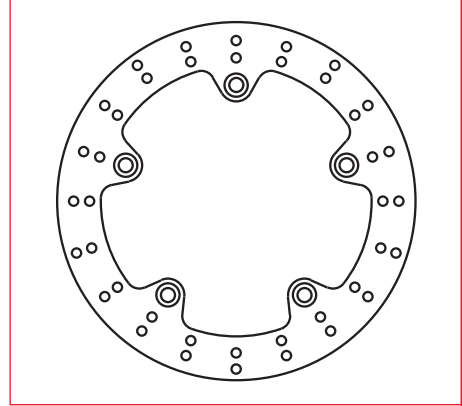

MST 457

A	B	C	D	E
270	129,3	5		146

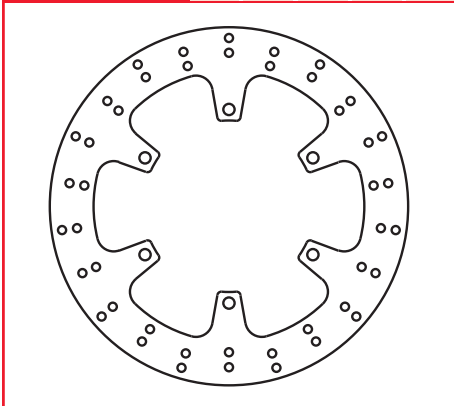

MST 458

A	B	C	D	E
300	145,3	5		170

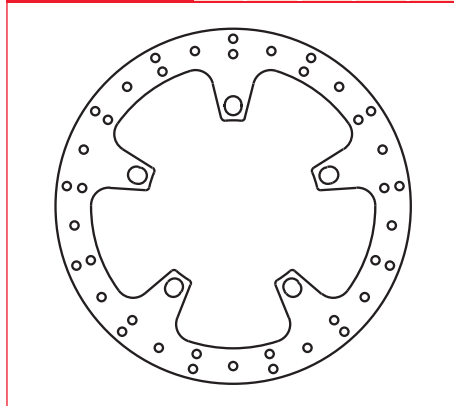

MST 459

A	B	C	D	E
280	142,3	5		163,5

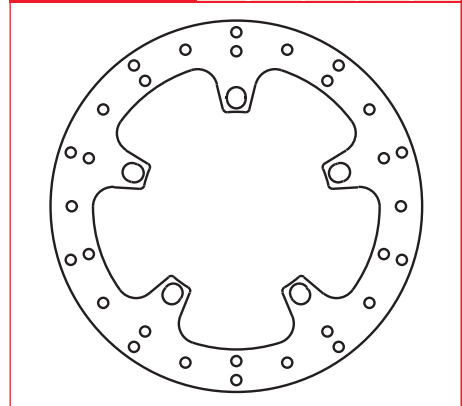

MST 460

A	B	C	D	E
290	120,8	5		141

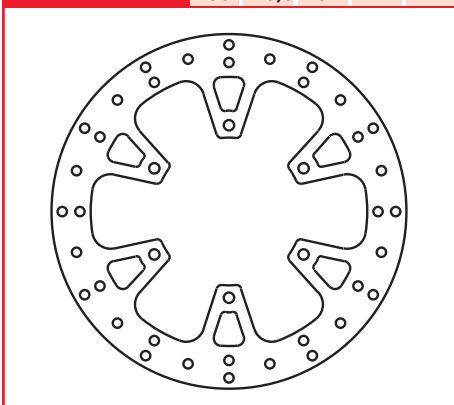

MST 461 RAC

A	B	C	D	E
245	83,3	5		102

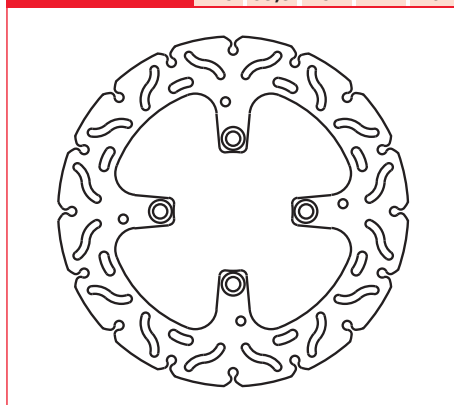

MST 462

A	B	C	D	E
282	105,3	5		127,5

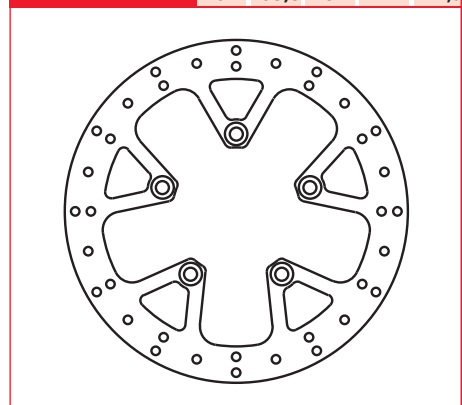

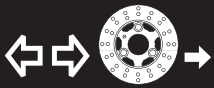

MST 463 EC

A	B	C	D	E
210	110,3	3,1		125

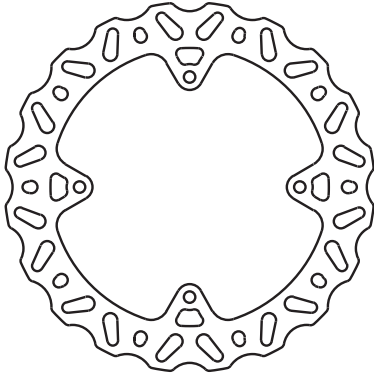

MST 464

A	B	C	D	E
276	136	5		160

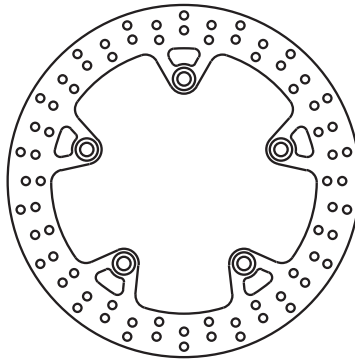

MST 464 RAC

A	B	C	D	E
276	136	5		160

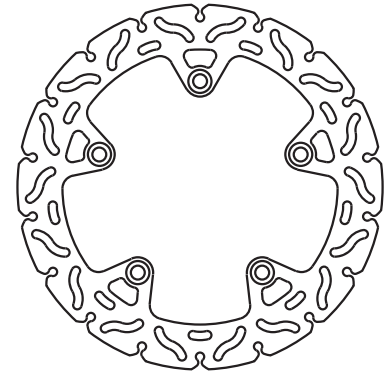

MST 465 RAC

A	B	C	D	E
320	210	5		256



MST 500

A	B	C	D	E
292	56,4	5		82,7

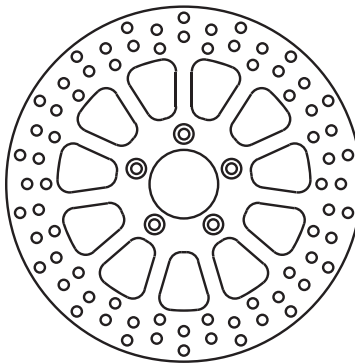

MST 500 SWL

A	B	C	D	E
292	56,4	5		82,7

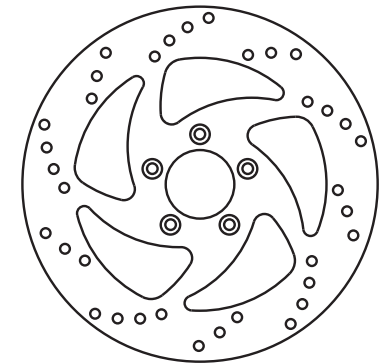

MST 500 SWR

A	B	C	D	E
292	56,4	5		82,7

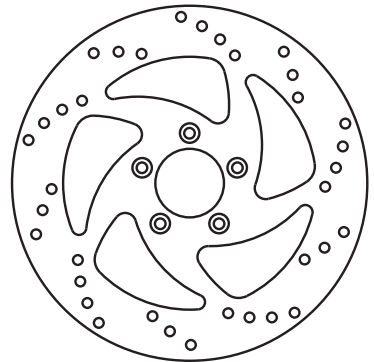

MST 501

A	B	C	D	E
292	56,4	5		82,7

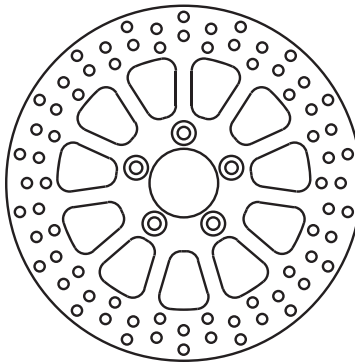

MST 501 SWL

A	B	C	D	E
292	56,4	5		82,7

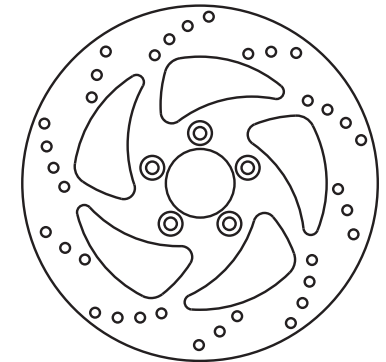

MST 501 SWR

A	B	C	D	E
292	56,4	5		82,7

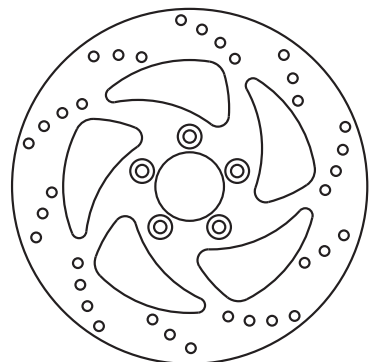

MST 503

A	B	C	D	E
260	56,4	5		82,7

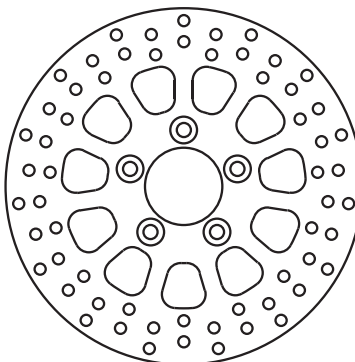

MST 503 SWL

A	B	C	D	E
260	56,4	5		82,7

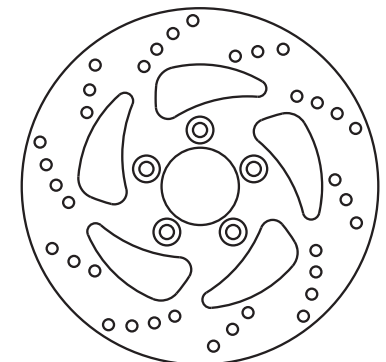



M	A	B	C	D	E

M	A	B	C	D	E

M	A	B	C	D	E

M	A	B	C	D	E

M	A	B	C	D	E

M	A	B	C	D	E

M	A	B	C	D	E

M	A	B	C	D	E

M	A	B	C	D	E

M	A	B	C	D	E

M	A	B	C	D	E

M	A	B	C	D	E



MSW 110

A	B	C	D	E
320	132	5		150

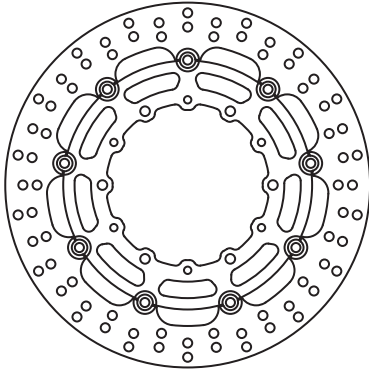

MSW 112

A	B	C	D	E
320	100	5		116

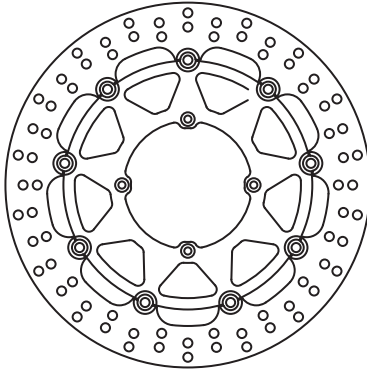

MSW 112 RAC

A	B	C	D	E
320	100	5		116

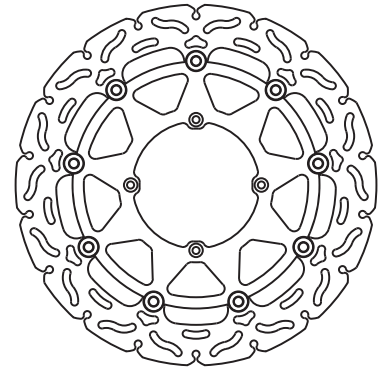

MSW 113

A	B	C	D	E
320	118	5		134

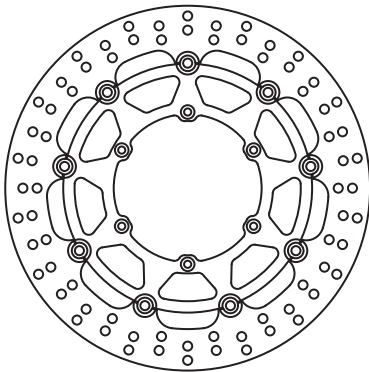

MSW 113 RAC

A	B	C	D	E
320	118	5		134

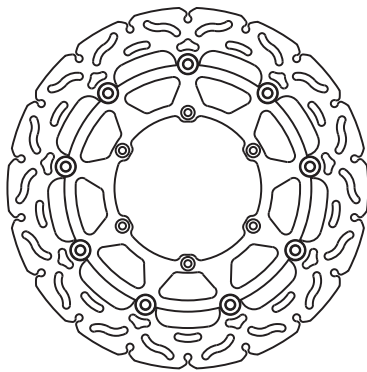

MSW 114

A	B	C	D	E
320	126,8	5		143

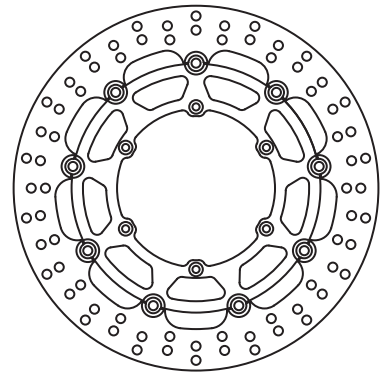

MSW 114 RAC

A	B	C	D	E
320	126,8	5		143

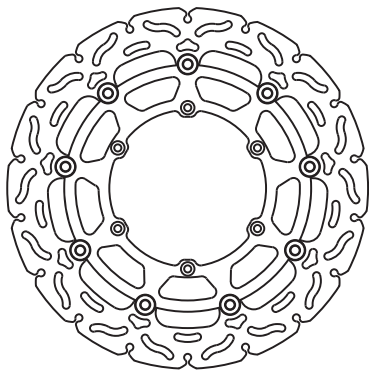

MSW 115

A	B	C	D	E
320	100	5		116

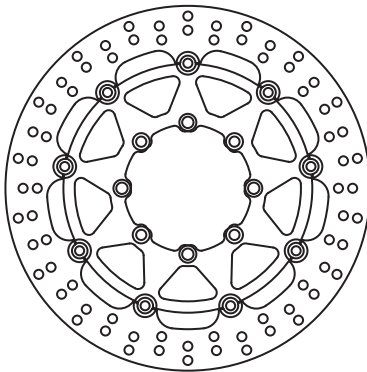

MSW 118

A	B	C	D	E
320	120	5		135

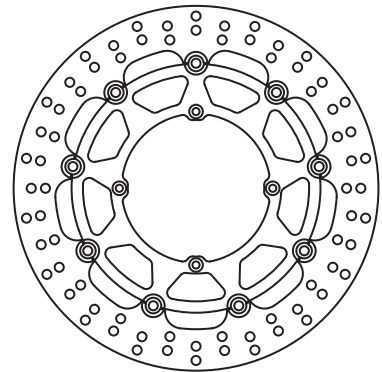

MSW 119

A	B	C	D	E
320	101	5		117

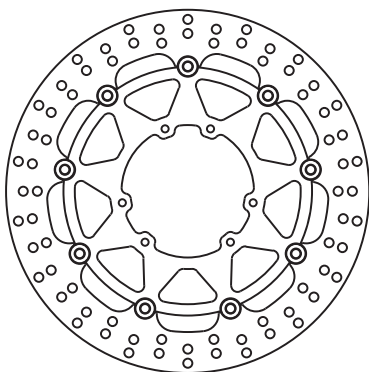

MSW 119 RAC

A	B	C	D	E
320	101	5		117

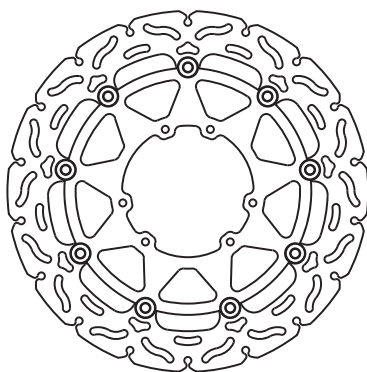

MSW 120

A	B	C	D	E
320	118	5		134

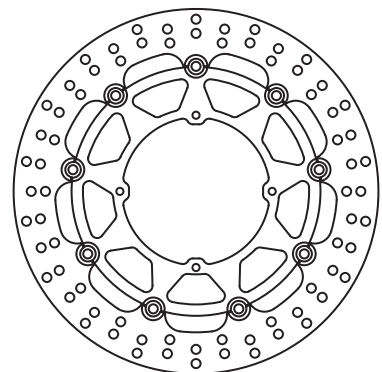



MSW 200

A	B	C	D	E
305	118	5		134

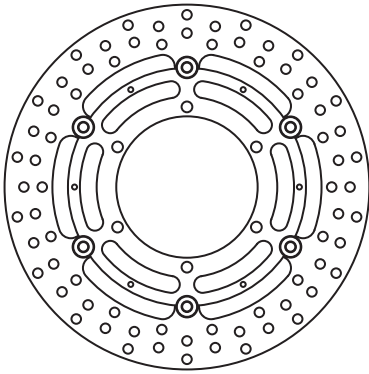

MSW 209 RAC

A	B	C	D	E
310	132,3	5		150

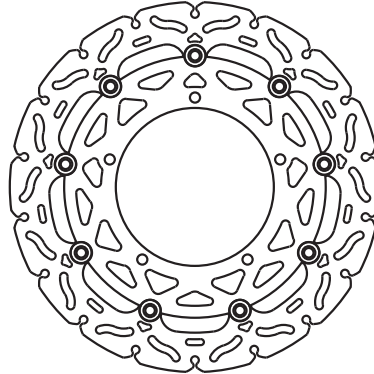

MSW 211

A	B	C	D	E
320	64	5	10	80

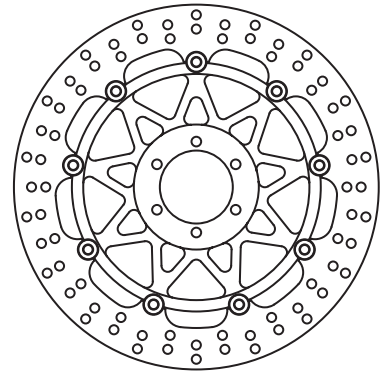

MSW 211 RAC

A	B	C	D	E
320	64	5	10	80

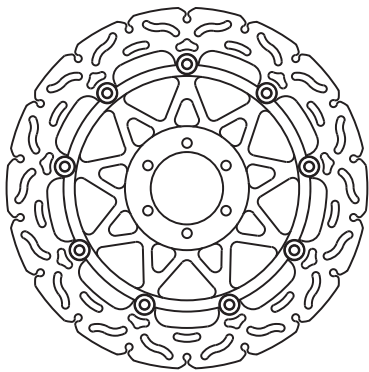

MSW 212

A	B	C	D	E
296	58	5	17	74

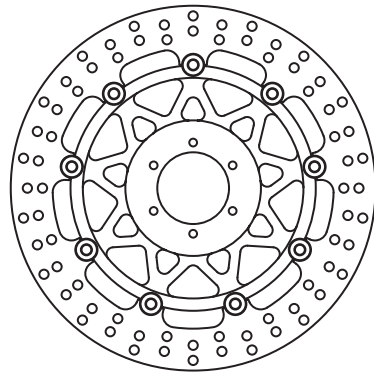

MSW 212 RAC

A	B	C	D	E
296	58	5	17	74

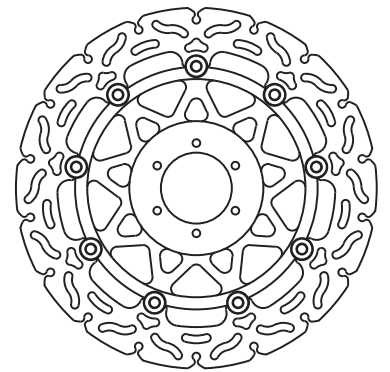

MSW 214

A	B	C	D	E
310	61	5	13,5	81

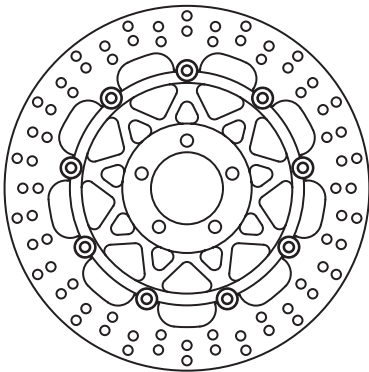

MSW 214 RAC

A	B	C	D	E
310	61	5	13,5	81

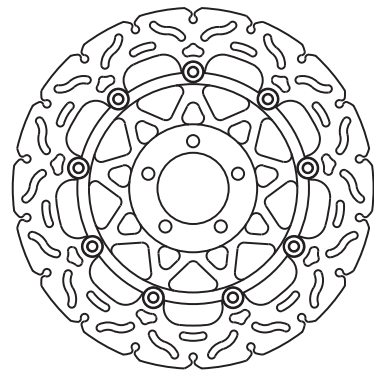

MSW 215

A	B	C	D	E
300	61	5	13,5	81

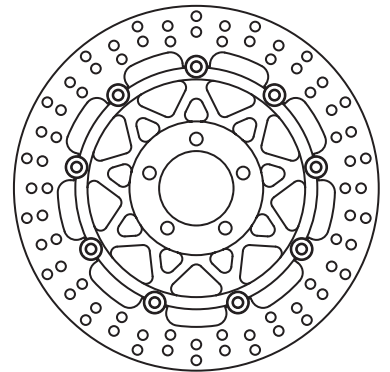

MSW 215 RAC

A	B	C	D	E
300	61	5	13,5	81

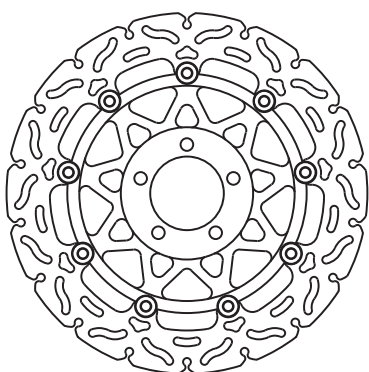

MSW 216

A	B	C	D	E
320	61	5	13,5	81

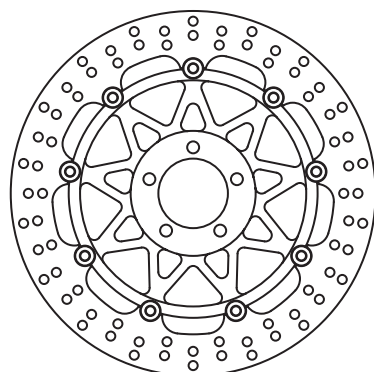

MSW 216 RAC

A	B	C	D	E
320	61	5	13,5	81

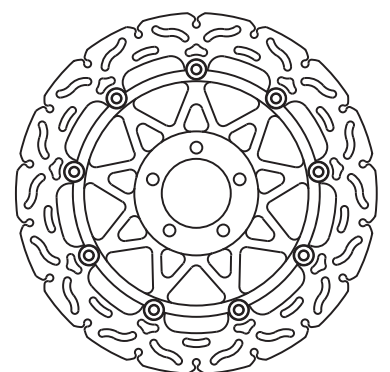

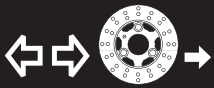

MSW 217

A	B	C	D	E
310	64	5	22,5	86

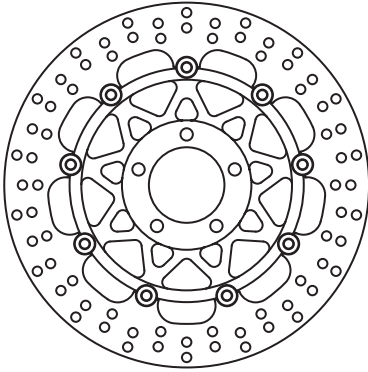

MSW 217 RAC

A	B	C	D	E
310	64	5	22,5	86

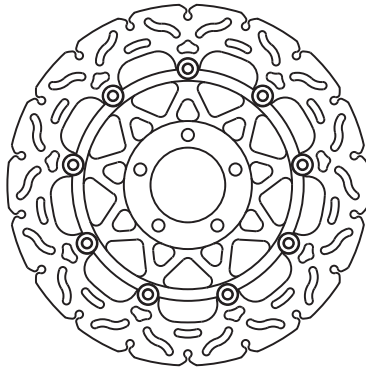

MSW 218

A	B	C	D	E
300	64	5	19,5	86

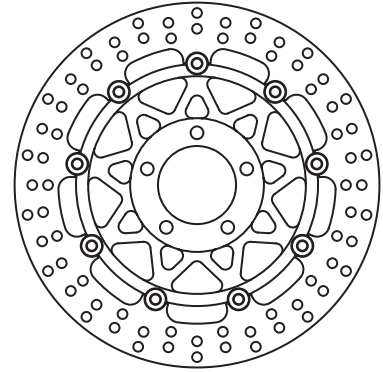

MSW 219

A	B	C	D	E
310	64	5	19,5	86

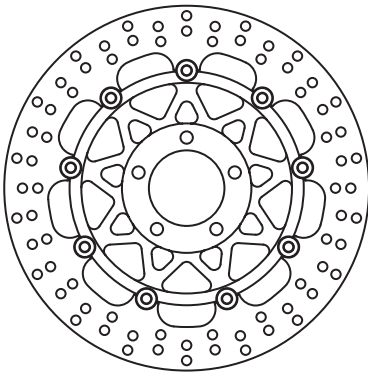

MSW 219 RAC

A	B	C	D	E
310	64	5	19,5	86

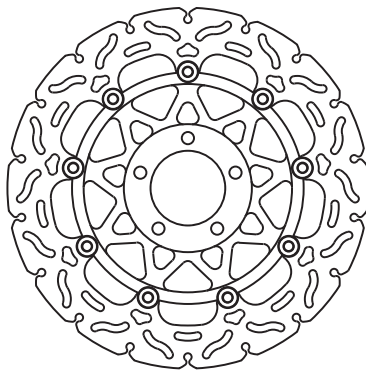

MSW 220

A	B	C	D	E
290	64	5	19,5	86

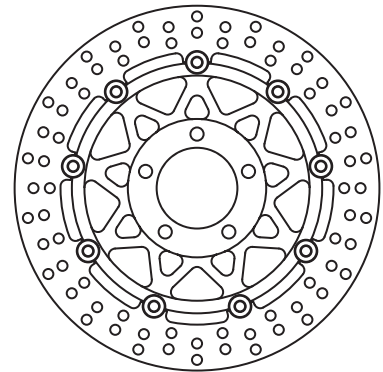

MSW 220 RAC

A	B	C	D	E
290	64	5	19,5	86

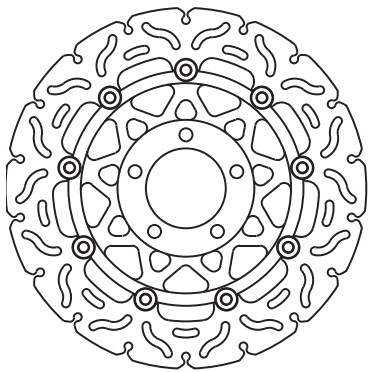

MSW 221

A	B	C	D	E
300	64	5	10	80

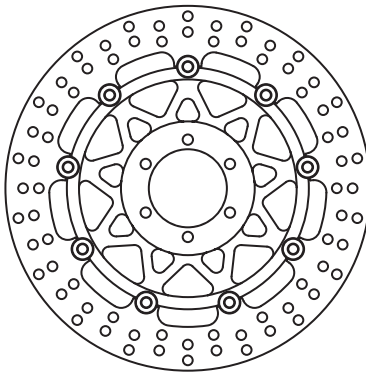

MSW 221 RAC

A	B	C	D	E
300	64	5	10	80

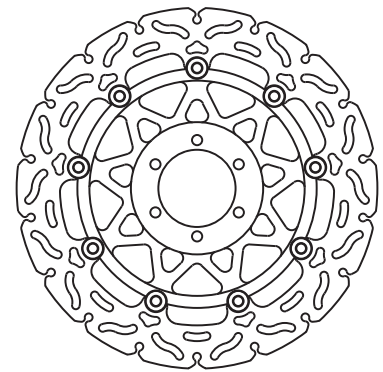

MSW 222

A	B	C	D	E
320	64	5	10	80

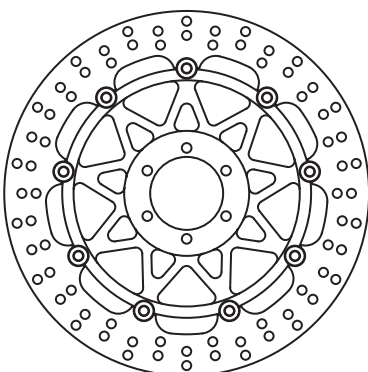

MSW 223

A	B	C	D	E
320	69	5		91

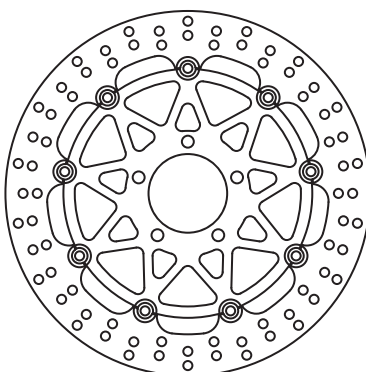

MSW 223 RAC

A	B	C	D	E
320	69	5		91

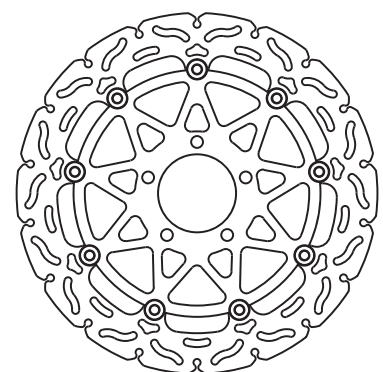



MSW 224

A	B	C	D	E
300	132	5		150

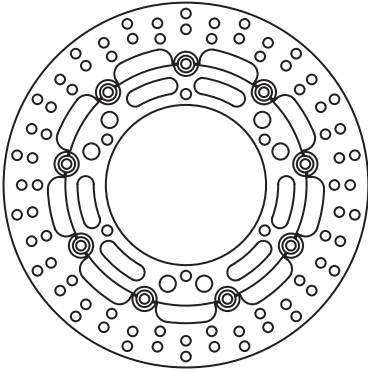

MSW 224 RAC

A	B	C	D	E
300	132	5		150

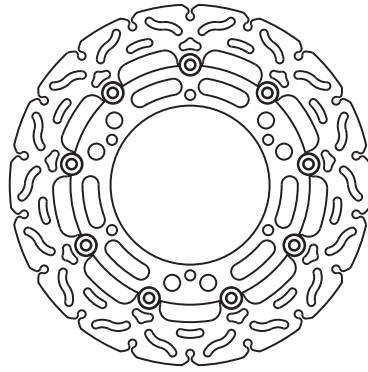

MSW 227

A	B	C	D	E
310	62	5	21,5	78

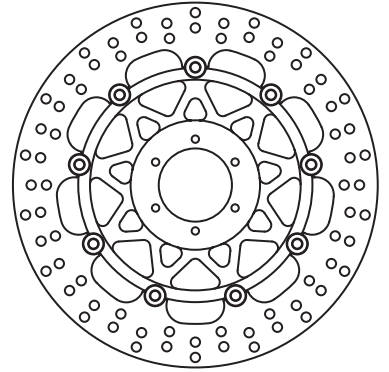

MSW 228

A	B	C	D	E
296	61	5	13,5	81

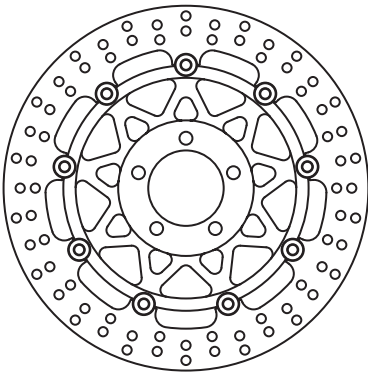

MSW 235

A	B	C	D	E
298	132	5		150

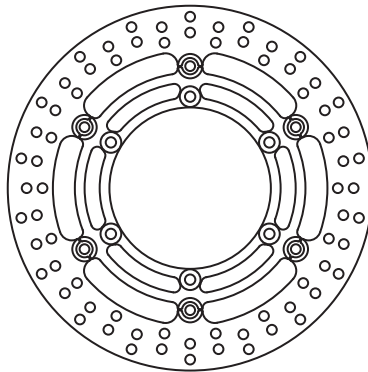

MSW 235 RAC Ersetzt durch MSW 224 RAC

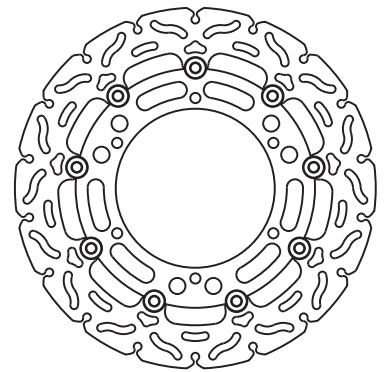

MSW 236

A	B	C	D	E
296	62	5	17	78

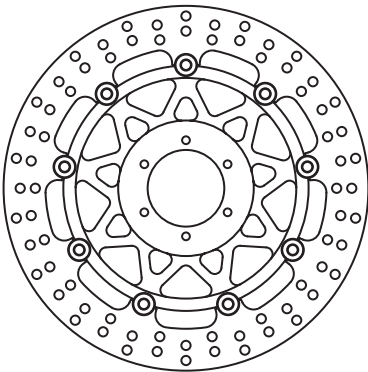

MSW 236 RAC

A	B	C	D	E
296	62	5	17	78

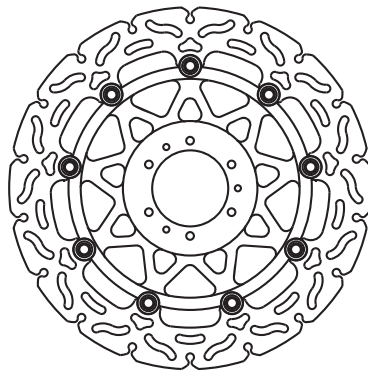

MSW 238

A	B	C	D	E
280	80,5	5		100

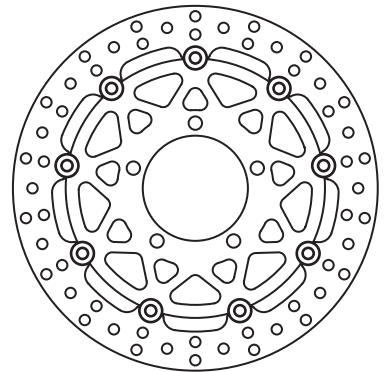

MSW 239

Ersetzt durch MSW 114

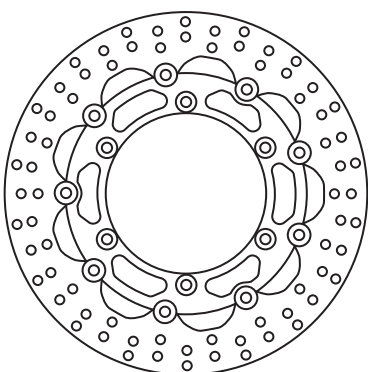

MSW 240

A	B	C	D	E
310	94	5	12,5	110

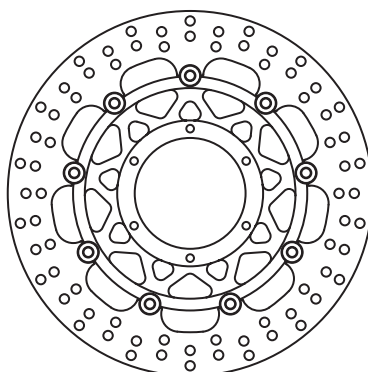

MSW 240 RAC

A	B	C	D	E
310	94	5	12,5	110

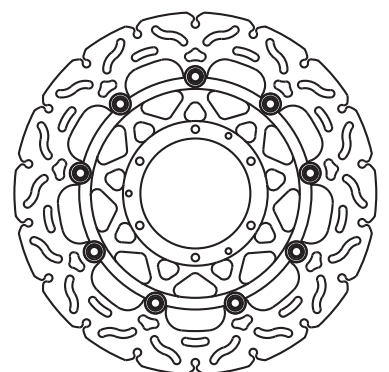



MSW 241

A	B	C	D	E
300	69	5		91

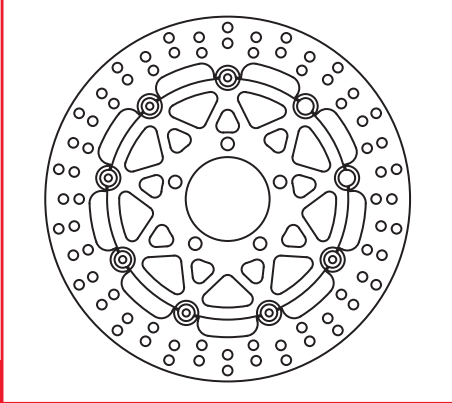

MSW 241 RAC

A	B	C	D	E
300	69	5		91

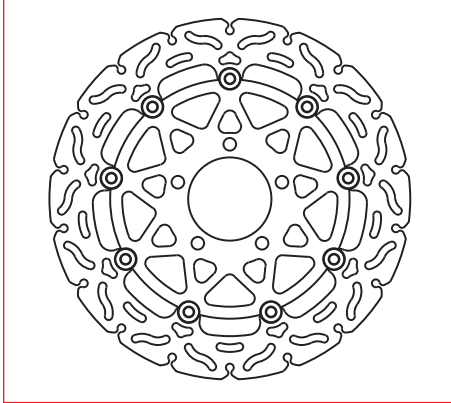

MSW 242

A	B	C	D	E
310	132	5		150

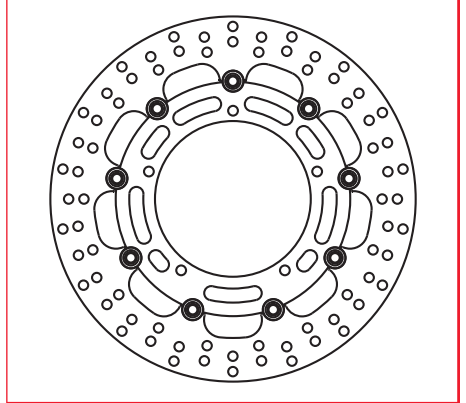

MSW 242 RAC

A	B	C	D	E
310	132	5		150

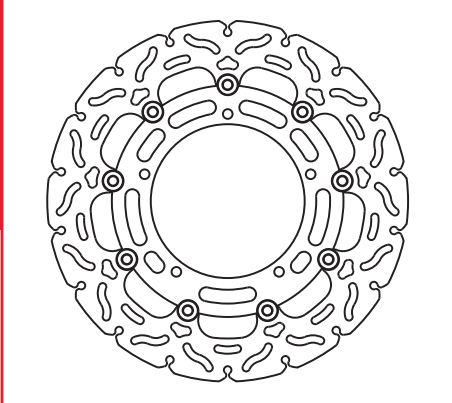

MSW 243

A	B	C	D	E
296	58	5	23,3	74

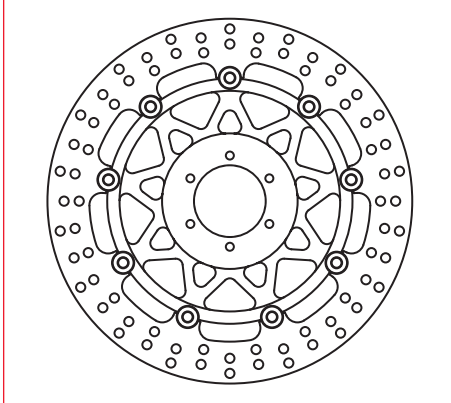

MSW 244

A	B	C	D	E
296	94	5	12,5	110

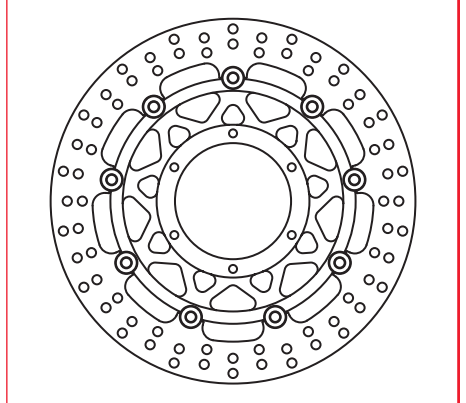

MSW 244 RAC

A	B	C	D	E
296	94	5	12,5	110

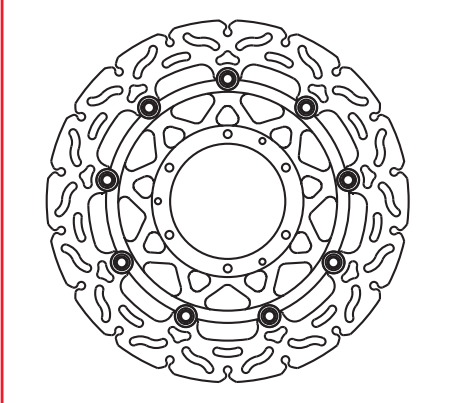

MSW 245

A	B	C	D	E
330	94	5	12,5	110

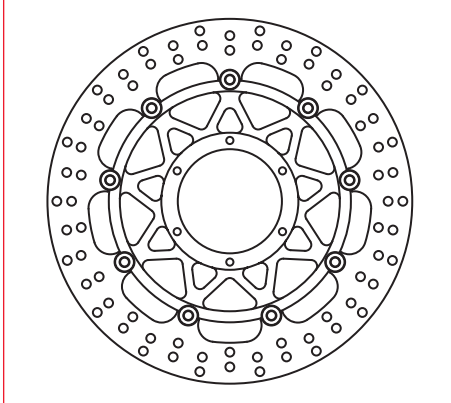

MSW 245 RAC

A	B	C	D	E
330	94	5	12,5	110

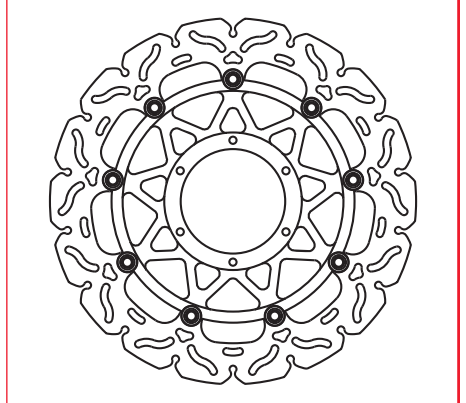

MSW 246

A	B	C	D	E
300	132	5		150

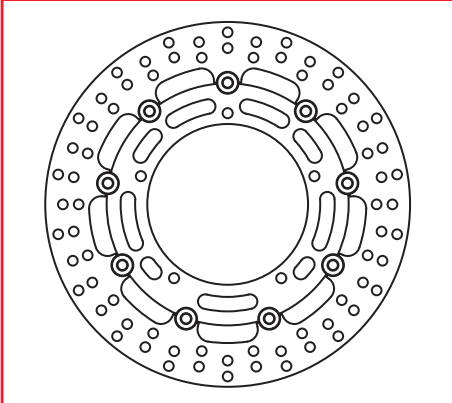

MSW 246 RAC

A	B	C	D	E
300	132	5		150

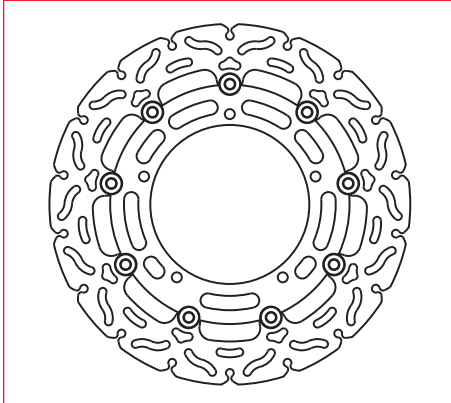

MSW 247

A	B	C	D	E
320	132	5		150

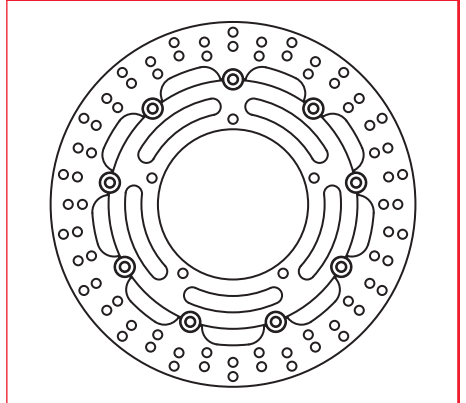



MSW 247 RAC

A	B	C	D	E
320	132	5		150

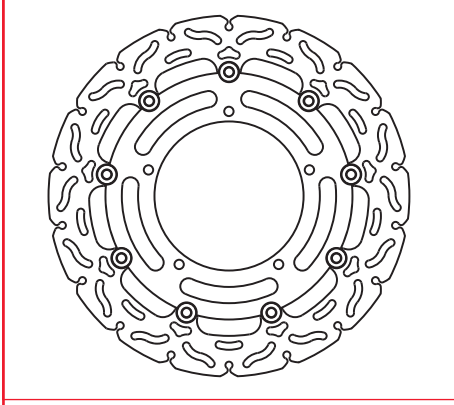

MSW 248

A	B	C	D	E
290	69	5		91

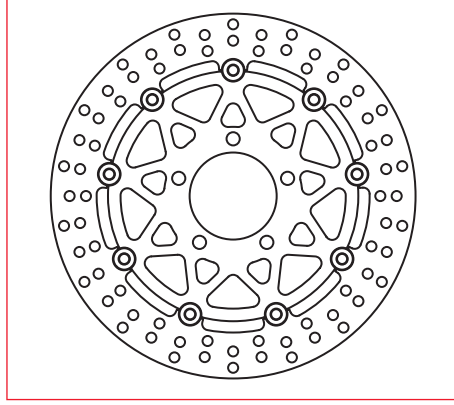

MSW 248 RAC

A	B	C	D	E
290	69	5		91

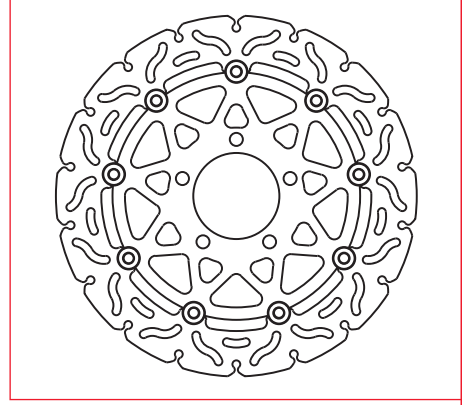

MSW 250

A	B	C	D	E
310	69	5		91

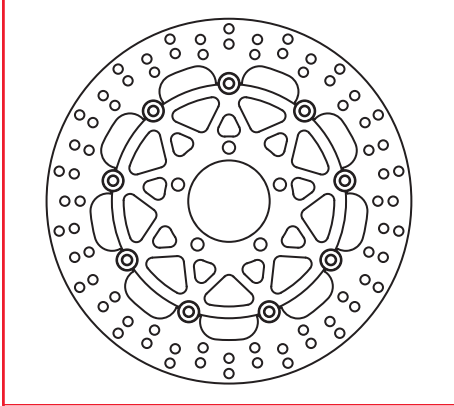

MSW 250 RAC

A	B	C	D	E
310	69	5		91

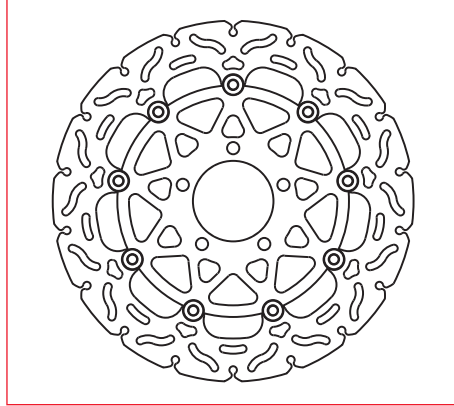

MSW 251

A	B	C	D	E
320	78	5	10,5	100,5

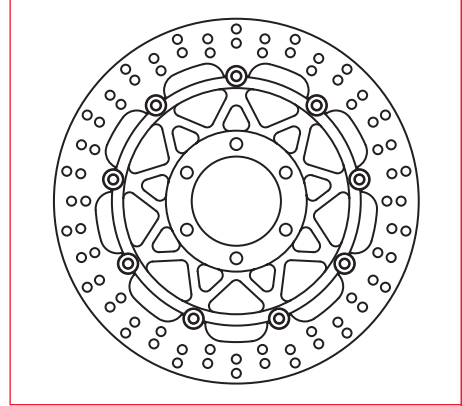

MSW 253

A	B	C	D	E
300	118,2	5		134

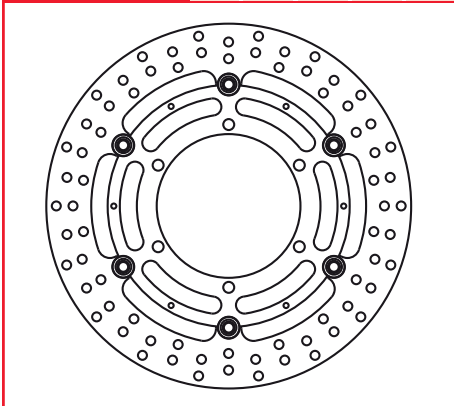

MSW 254

A	B	C	D	E
320	94	5	12,5	110

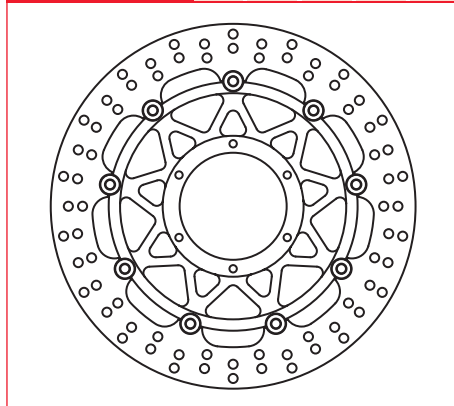

MSW 254 RAC

A	B	C	D	E
320	94	5	12,5	110

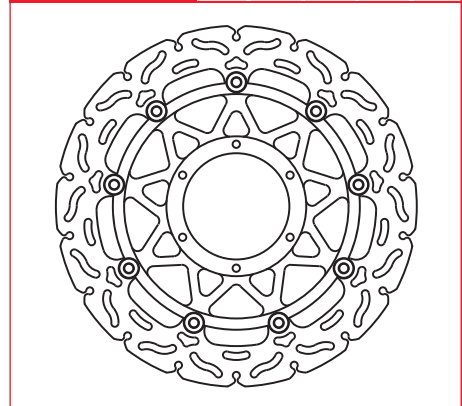

MSW 255 RAC

A	B	C	D	E
310	100	5		120

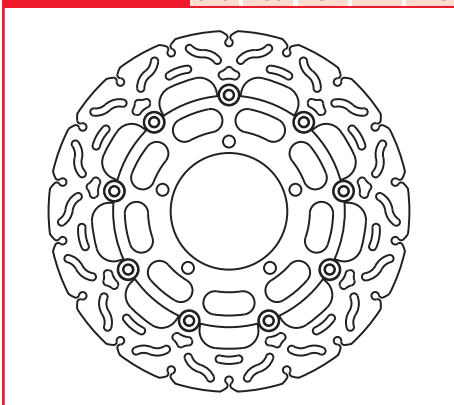

MSW 257 RAC

A	B	C	D	E
300	80	5		100

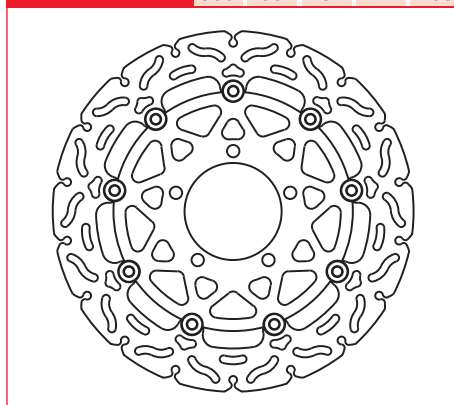

MSW 258 RAC

A	B	C	D	E
310	62	5	18,5	78

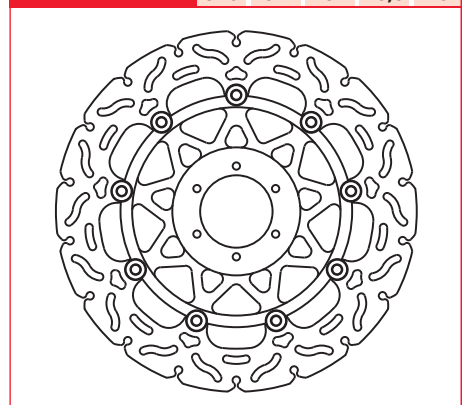

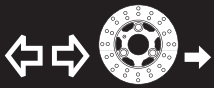

MSW 259

A	B	C	D	E
310	121,5	5		142

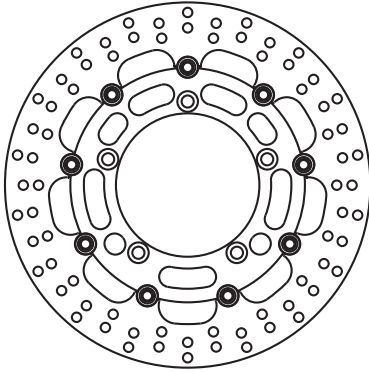

MSW 259 RAC

A	B	C	D	E
310	121,5	5		142

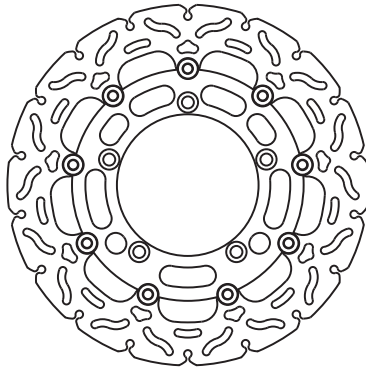

MSW 260 RAC

A	B	C	D	E
290	121,5	5		142

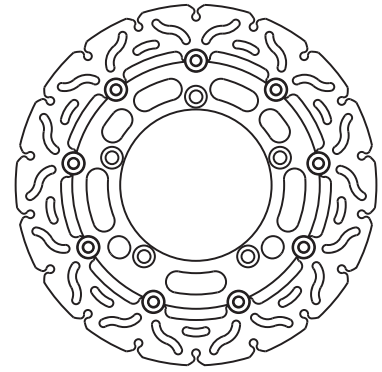

MSW 261 RAC

A	B	C	D	E
310	84,5	5	14,5	100,5

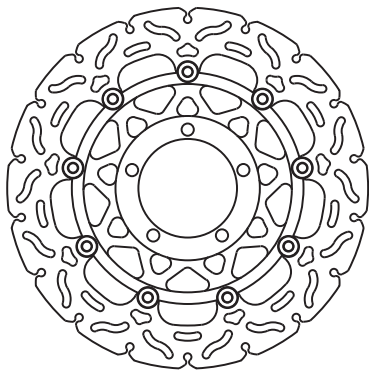

MSW 262 RAC

A	B	C	D	E
320	132	5		150

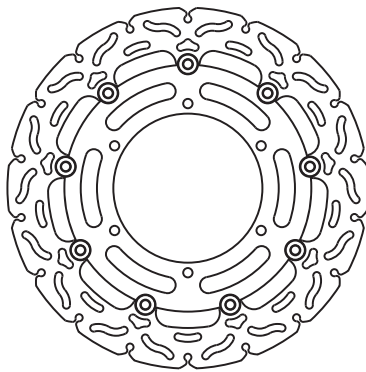

MSW 264 RAC

A	B	C	D	E
310	80,5	5		100

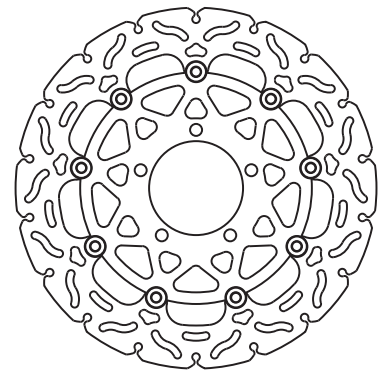

MSW 265 RAC

A	B	C	D	E
320	94	5	15,25	110

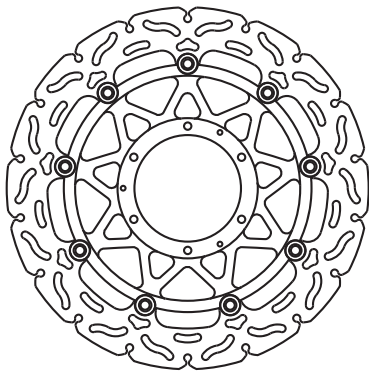

MSW 266 RAC

A	B	C	D	E
310	102	5		120

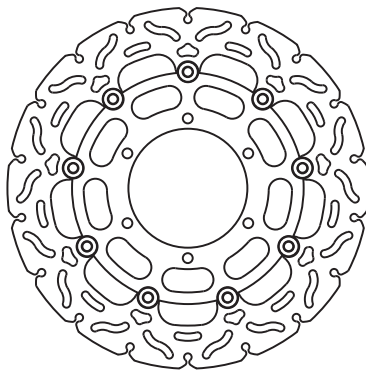

MSW 267 RAC

A	B	C	D	E
320	72	5	15	90

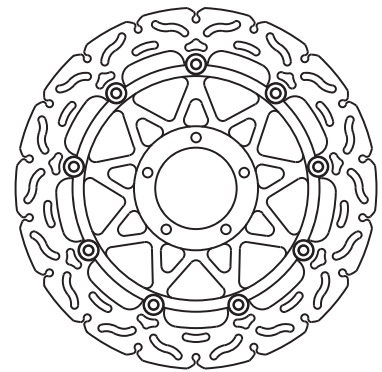

MSW 268

A	B	C	D	E
267	132	4		150

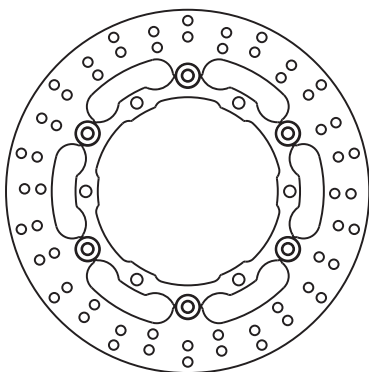

MSW 269

A	B	C	D	E
267	132	4		150

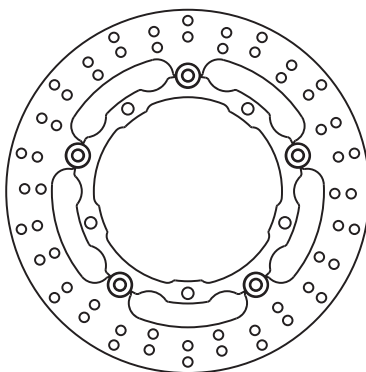

MSW 270 RAC

A	B	C	D	E
320	105	5		120

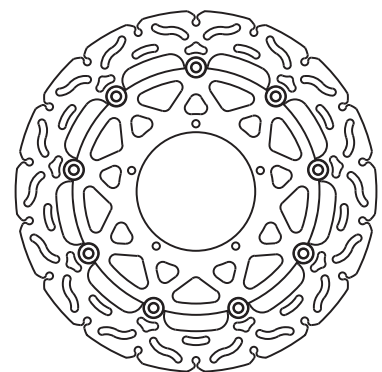



MSW 271

A	B	C	D	E
320	132	5	15	150

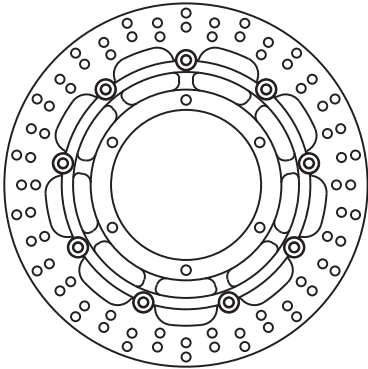

MSW 272

A	B	C	D	E
296	94	5	17,5	110

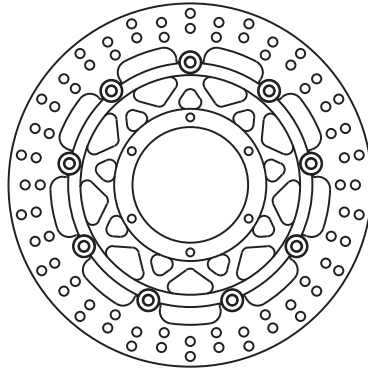

MSW 273RAC

A	B	C	D	E
310	132	5		150

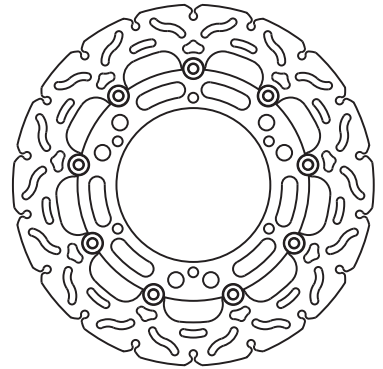

MSW 274RAC

A	B	C	D	E
300	80,5	5	-	100

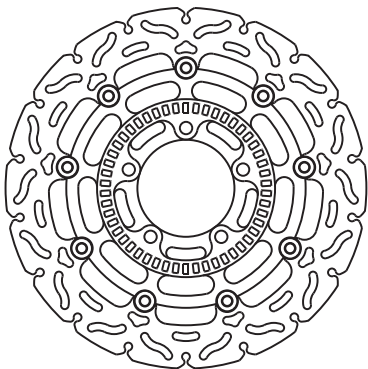

MSW 276

A	B	C	D	E
320	105	5		166

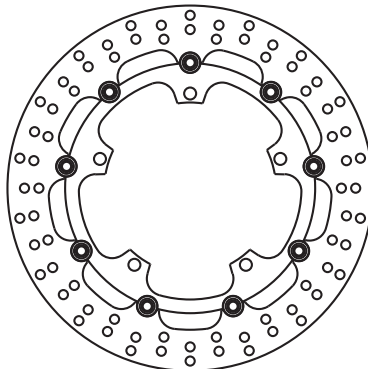

MSW 277RAC

A	B	C	D	E
300	126	5		228

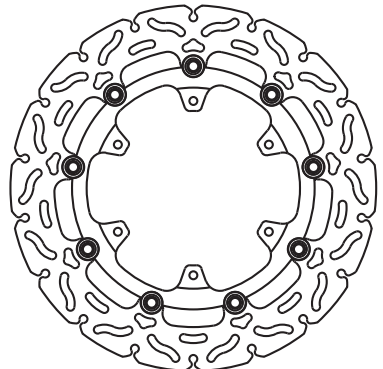

MSW 278

A	B	C	D	E
320	78	5	17,5	100

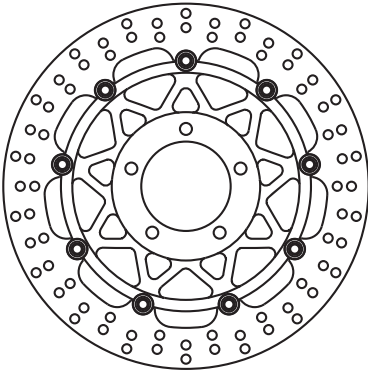

MSW 279

A	B	C	D	E
320	78	5	14,5	100

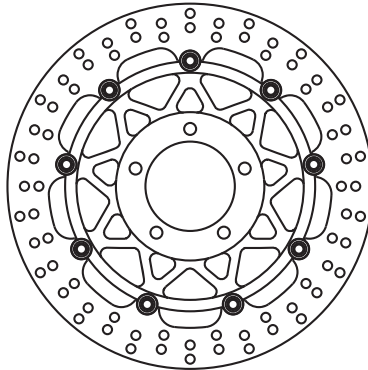

MSW 280RAC

A	B	C	D	E
330	72	5	15	90

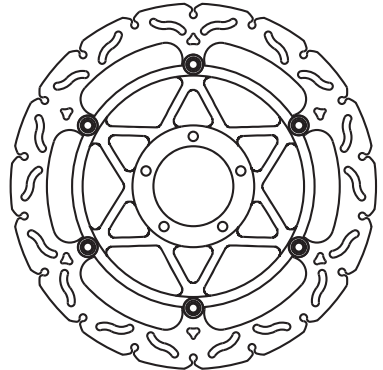

MSW 281RAC

A	B	C	D	E
305	72	5	10	90

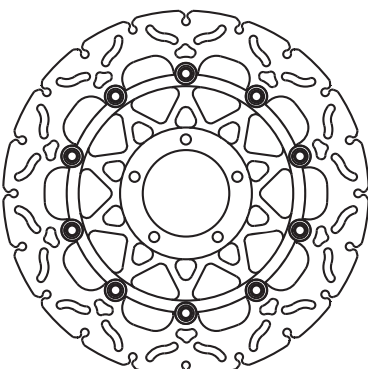

MSW 282RAC

A	B	C	D	E
305	64	5	10	80

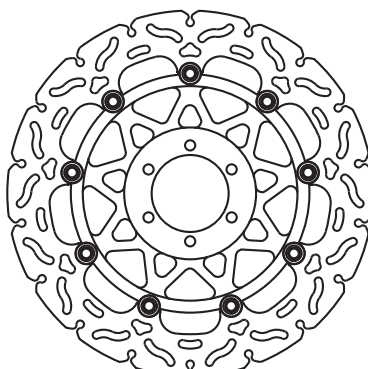

MSW 283RAC

A	B	C	D	E
296	94	5	14,5	110

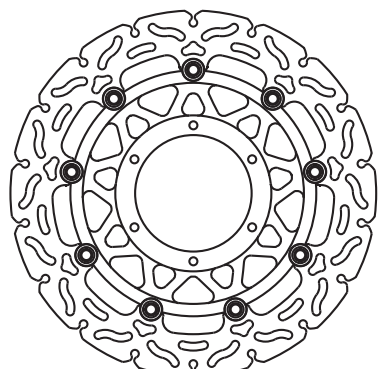

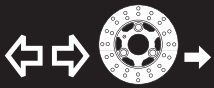

MSW 284

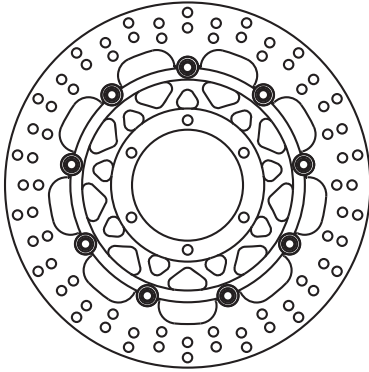
A	B	C	D	E
310	94	5	21,5	110

MSW 285 RAC

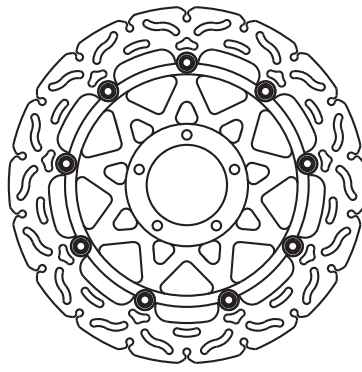
A	B	C	D	E
320	72	5	10	90

MSW 286

A	B	C	D	E
305	84,7	5		100

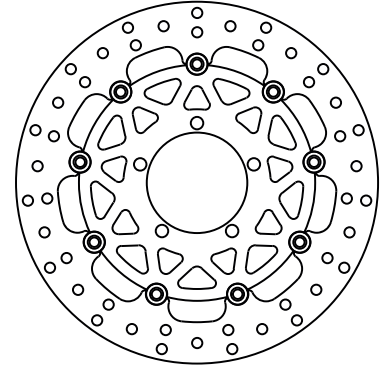
MSW 310

A	B	C	D	E
320	132	4		150

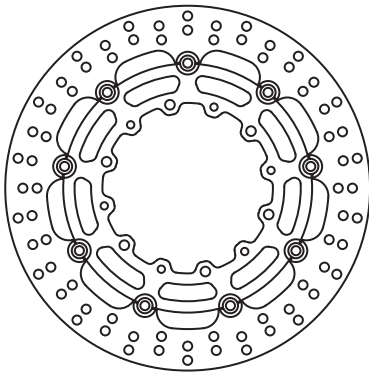
MSW 312

A	B	C	D	E
320	100	4		116

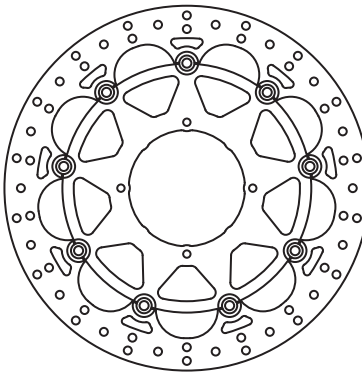
MSW 313

A	B	C	D	E
320	118	4		134

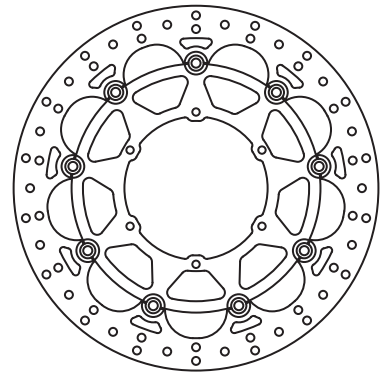
MSW 314

A	B	C	D	E
320	126,8	4		143

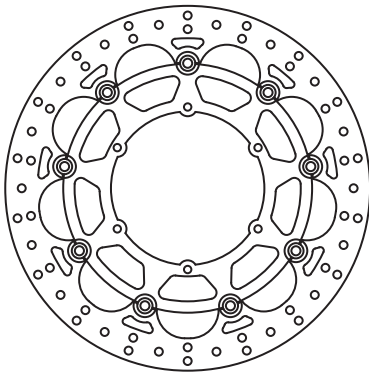
MSW 315

A	B	C	D	E
320	100	4		116

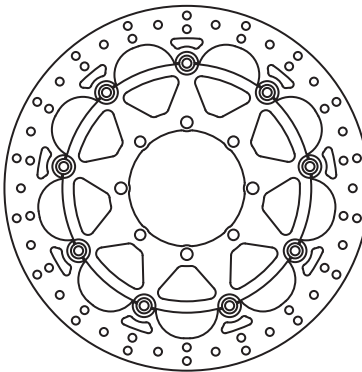
MSW 318

A	B	C	D	E
320	120	4		135

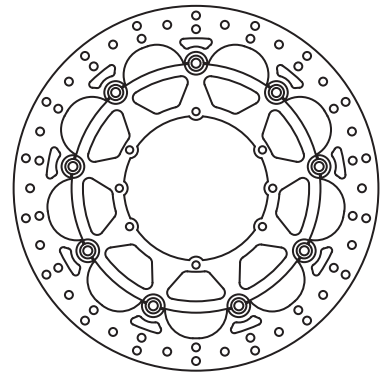
MSW 319

A	B	C	D	E
320	101	4		117

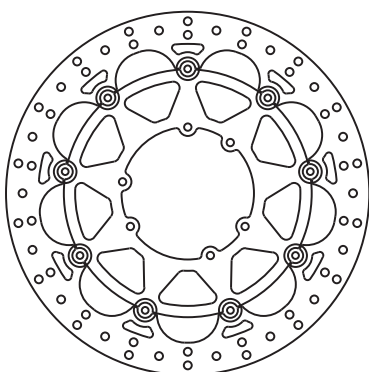
MSW 320

A	B	C	D	E
320	118	4		134

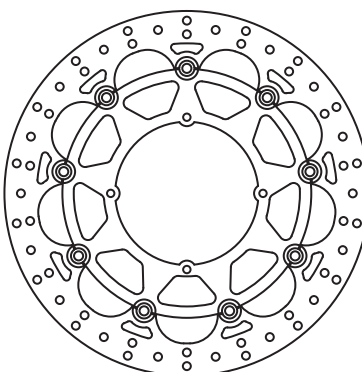
MSW 322

A	B	C	D	E
320	118	4		134

